

C12RSH3

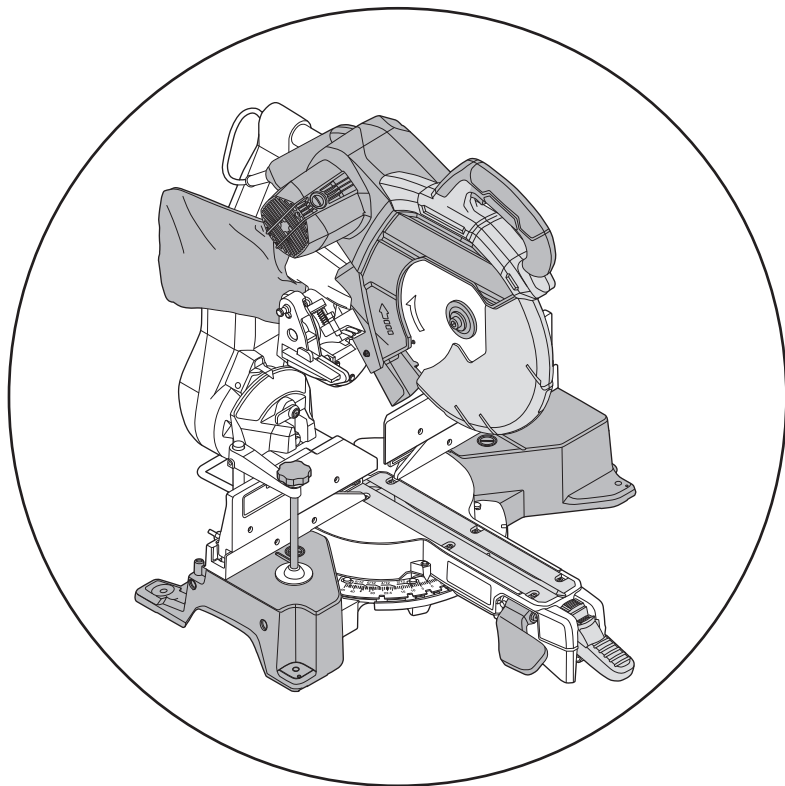

en Handling instructions

zh 使用說明書



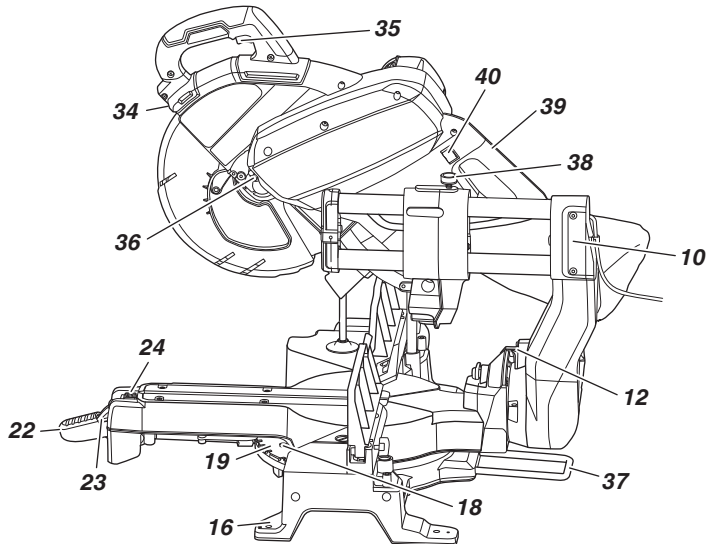
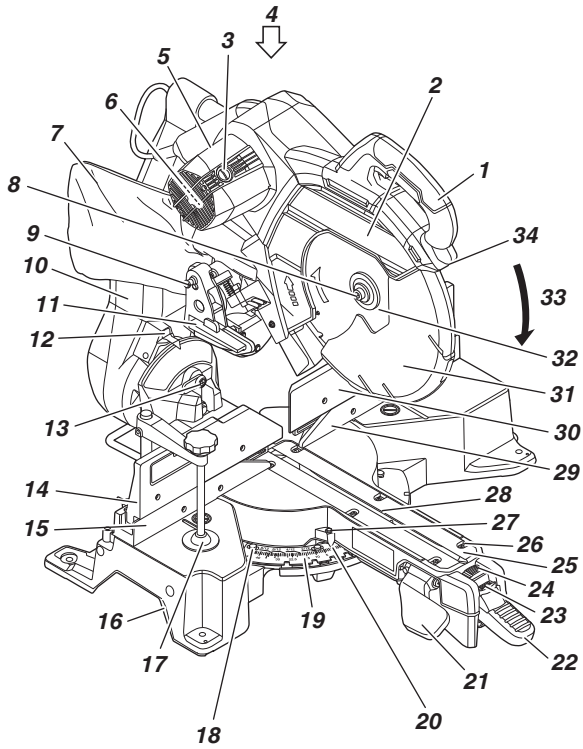

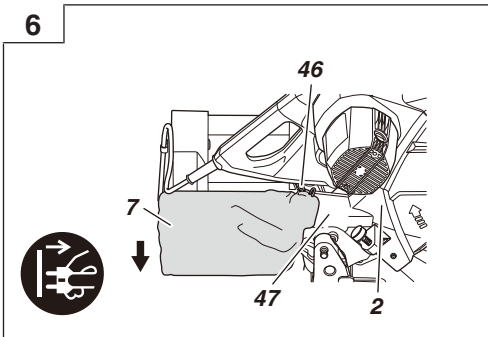
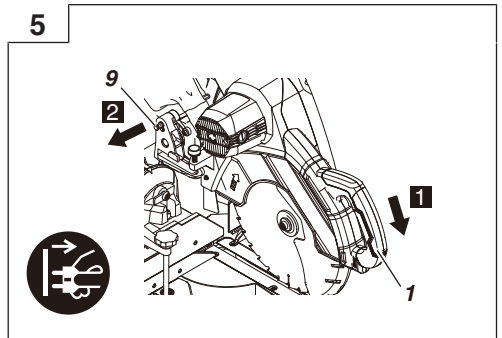
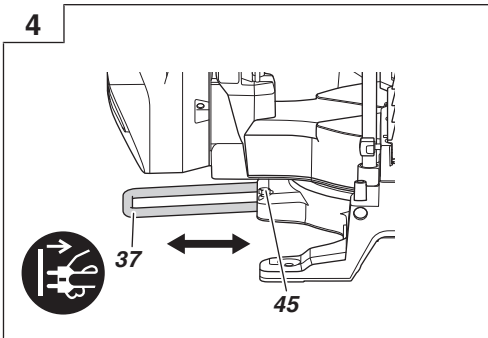
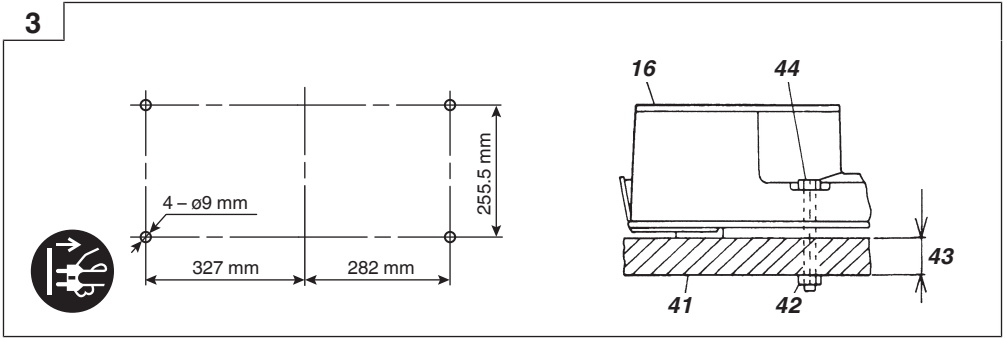
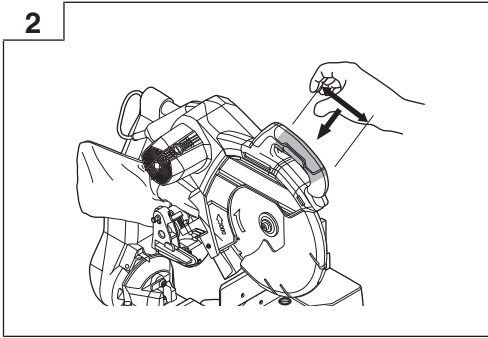

7

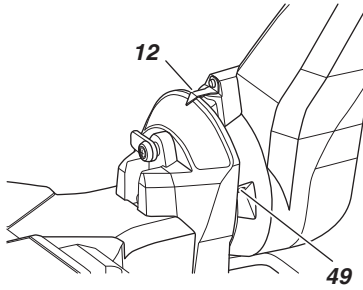

a

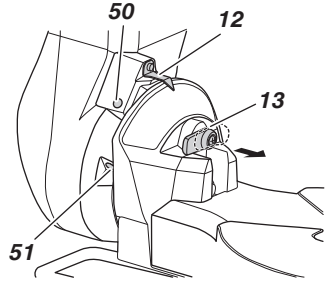

b

8

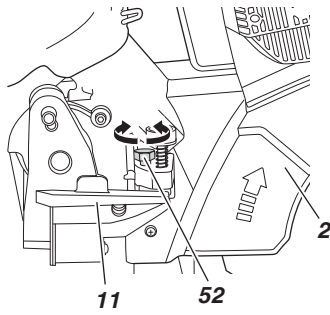

11

52

2

9

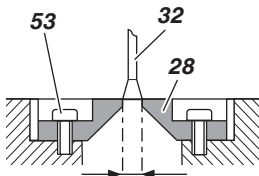

a

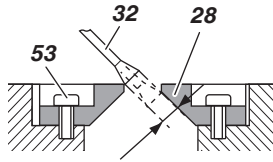

b

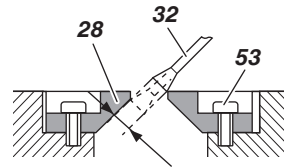

c

10

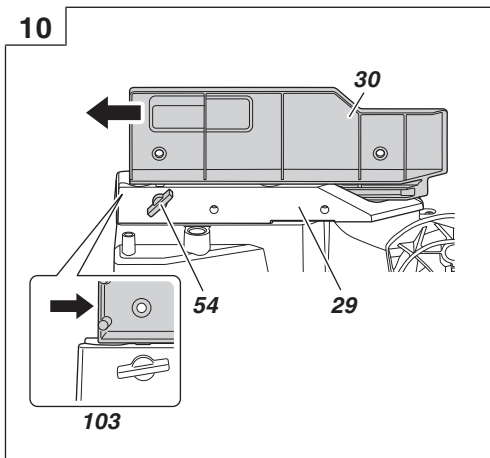

11

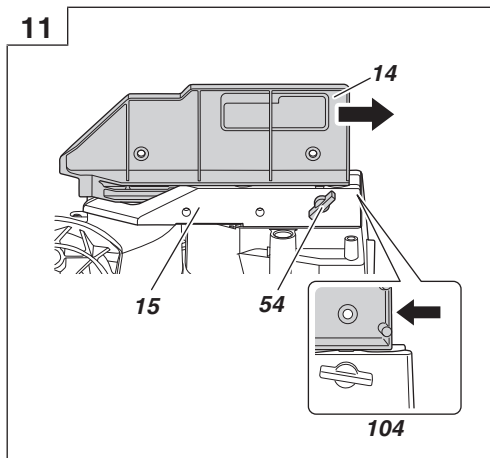

12

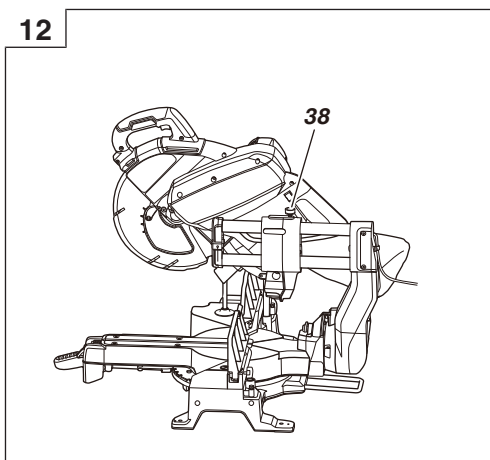

13

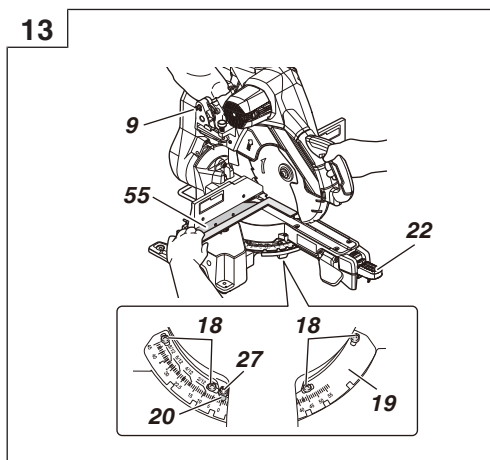

14

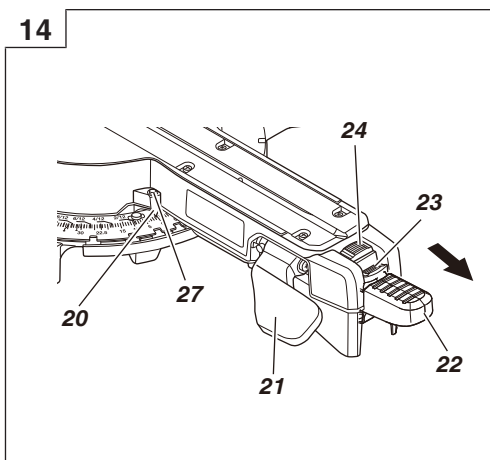

15

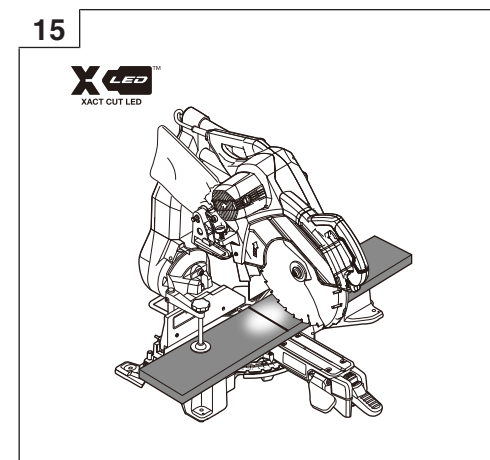

16

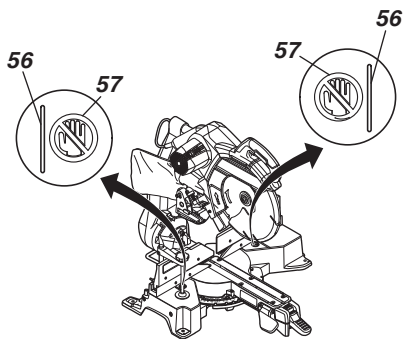

17

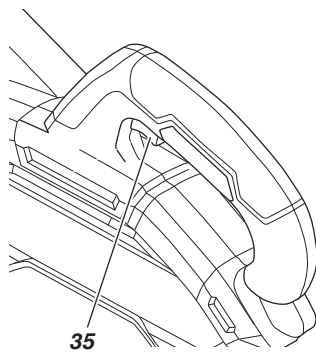

18

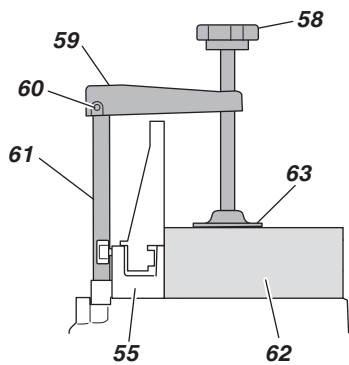

19

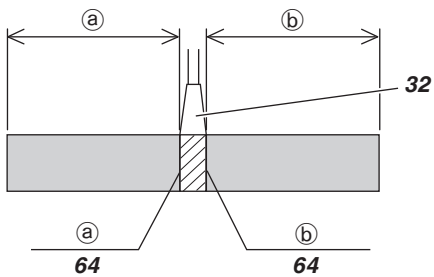
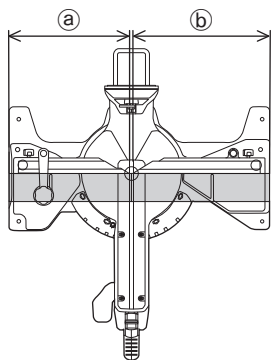

20

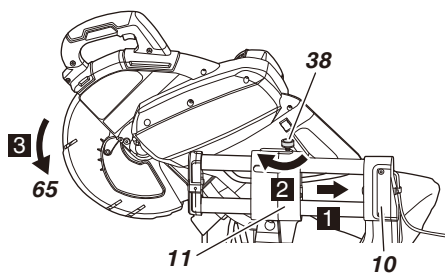

21

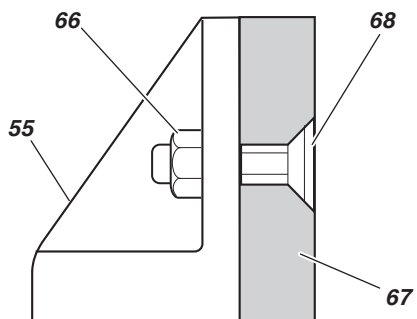

22

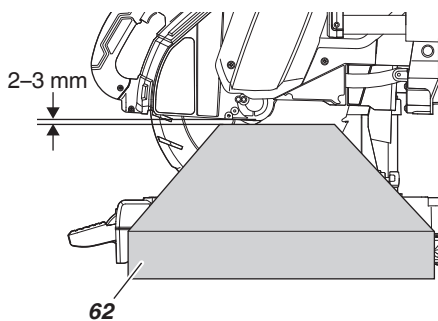
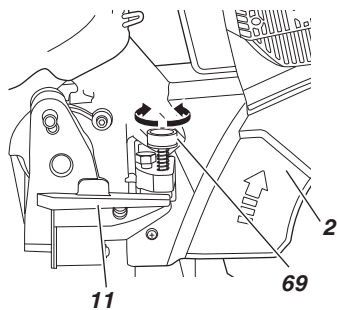

23

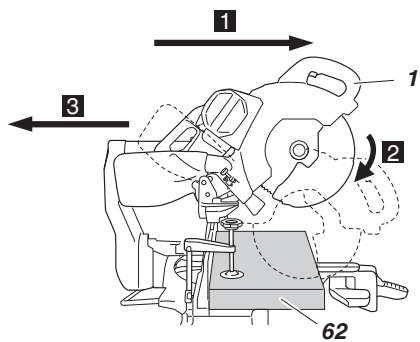

24

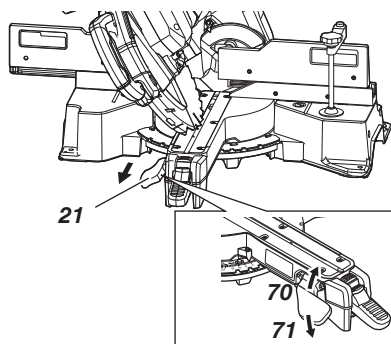

25

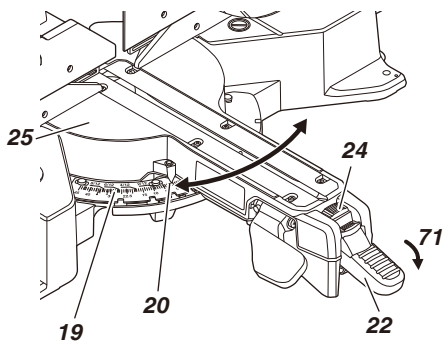

26

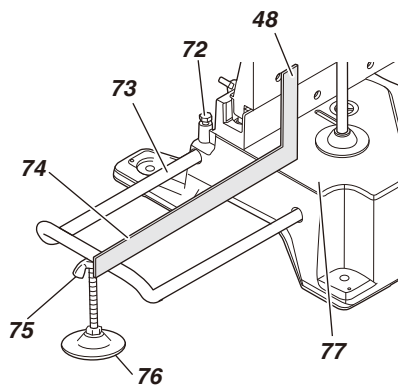

27

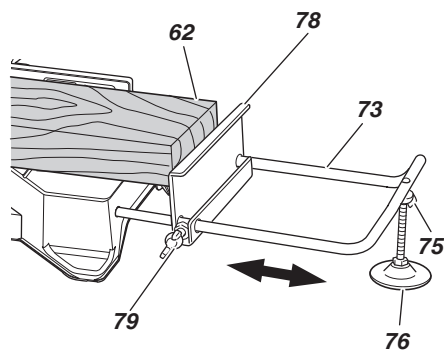

28

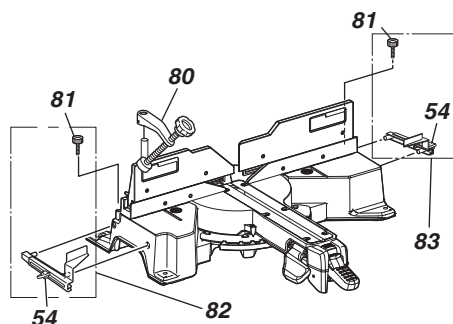

29

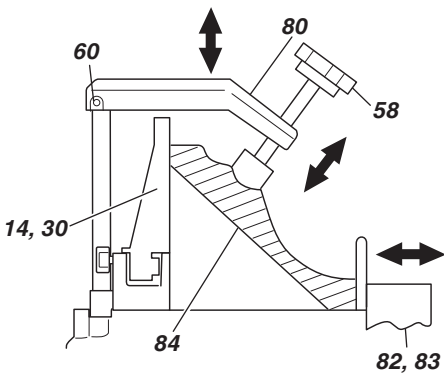

30

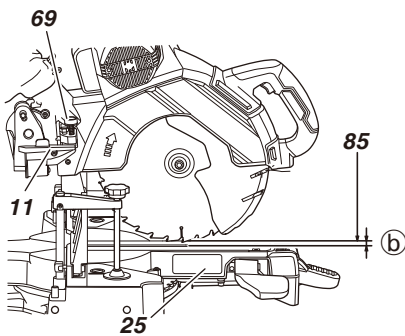

31

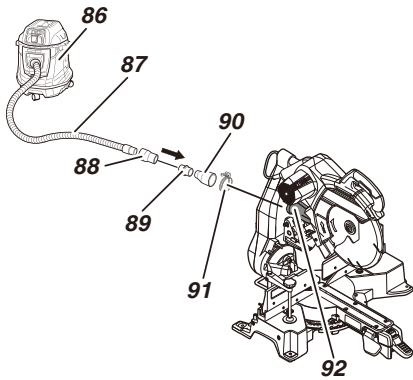

32

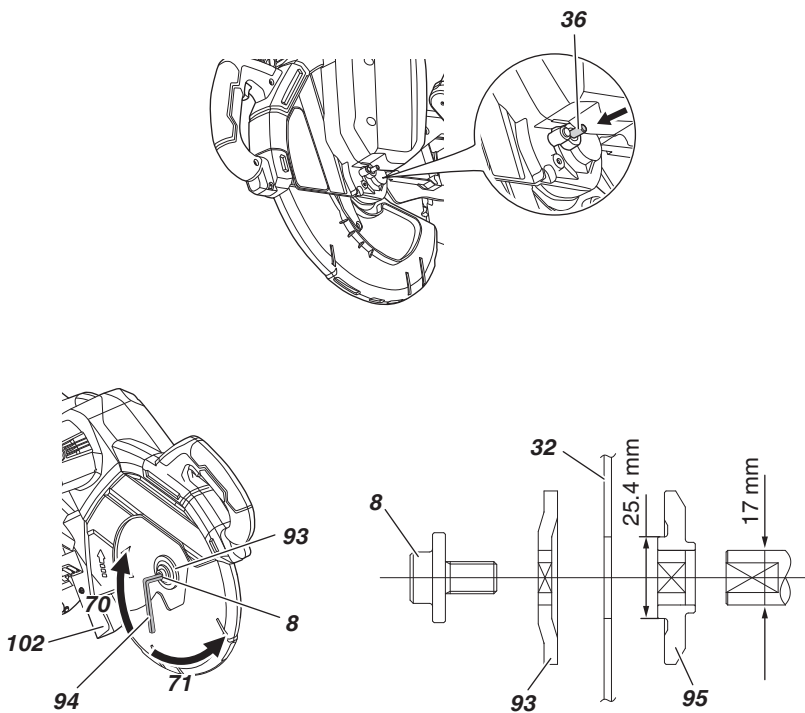

33

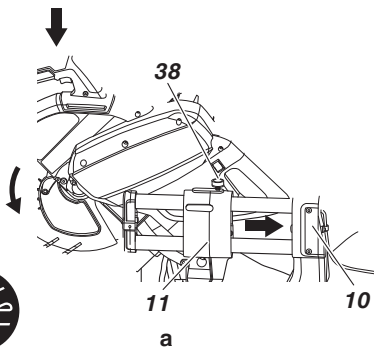

a

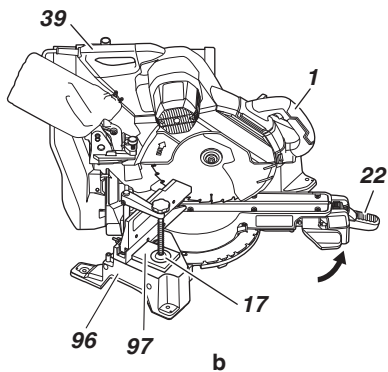

b

34

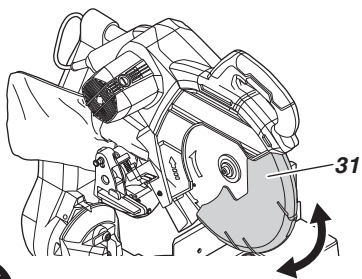

35

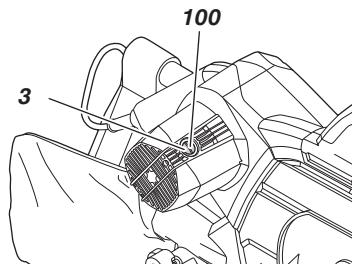
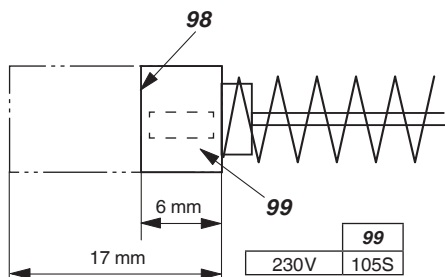

36

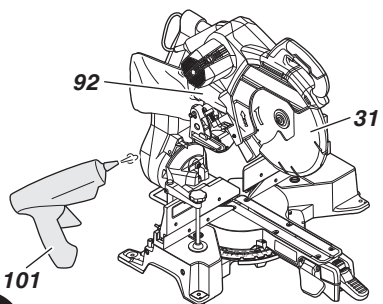

GENERAL POWER TOOL SAFETY WARNINGS

⚠ WARNING

Read all safety warnings, instructions, illustrations and specifications provided with this power tool.

Failure to follow all instructions listed below may result in electric shock, fire and/or serious injury.

Save all warnings and instructions for future reference.

The term "power tool" in the warnings refers to your mains-operated (corded) power tool or battery-operated (cordless) power tool.

1) Work area safety

- a) **Keep work area clean and well lit.**
Cluttered or dark areas invite accidents.
- b) **Do not operate power tools in explosive atmospheres, such as in the presence of flammable liquids, gases or dust.**
Power tools create sparks which may ignite the dust or fumes.
- c) **Keep children and bystanders away while operating a power tool.**
Distractions can cause you to lose control.

2) Electrical safety

- a) **Power tool plugs must match the outlet. Never modify the plug in any way. Do not use any adapter plugs with earthed (grounded) power tools.**
Unmodified plugs and matching outlets will reduce risk of electric shock.
- b) **Avoid body contact with earthed or grounded surfaces, such as pipes, radiators, ranges and refrigerators.**
There is an increased risk of electric shock if your body is earthed or grounded.
- c) **Do not expose power tools to rain or wet conditions.**
Water entering a power tool will increase the risk of electric shock.
- d) **Do not abuse the cord. Never use the cord for carrying, pulling or unplugging the power tool. Keep cord away from heat, oil, sharp edges or moving parts.**
Damaged or entangled cords increase the risk of electric shock.
- e) **When operating a power tool outdoors, use an extension cord suitable for outdoor use.**
Use of a cord suitable for outdoor use reduces the risk of electric shock.
- f) **If operating a power tool in a damp location is unavoidable, use a residual current device (RCD) protected supply.**
Use of an RCD reduces the risk of electric shock.

3) Personal safety

- a) **Stay alert, watch what you are doing and use common sense when operating a power tool. Do not use a power tool while you are tired or under the influence of drugs, alcohol or medication.**
A moment of inattention while operating power tools may result in serious personal injury.
- b) **Use personal protective equipment. Always wear eye protection.**
Protective equipment such as a dust mask, non-skid safety shoes, hard hat or hearing protection used for appropriate conditions will reduce personal injuries.

- c) **Prevent unintentional starting. Ensure the switch is in the off-position before connecting to power source and/or battery pack, picking up or carrying the tool.**
Carrying power tools with your finger on the switch or energising power tools that have the switch on invites accidents.
 - d) **Remove any adjusting key or wrench before turning the power tool on.**
A wrench or a key left attached to a rotating part of the power tool may result in personal injury.
 - e) **Do not overreach. Keep proper footing and balance at all times.**
This enables better control of the power tool in unexpected situations.
 - f) **Dress properly. Do not wear loose clothing or jewellery. Keep your hair and clothing away from moving parts.**
Loose clothes, jewellery or long hair can be caught in moving parts.
 - g) **If devices are provided for the connection of dust extraction and collection facilities, ensure these are connected and properly used.**
Use of dust collection can reduce dust-related hazards.
 - h) **Do not let familiarity gained from frequent use of tools allow you to become complacent and ignore tool safety principles.**
A careless action can cause severe injury within a fraction of a second.
- #### **4) Power tool use and care**
- a) **Do not force the power tool. Use the correct power tool for your application.**
The correct power tool will do the job better and safer at the rate for which it was designed.
 - b) **Do not use the power tool if the switch does not turn it on and off.**
Any power tool that cannot be controlled with the switch is dangerous and must be repaired.
 - c) **Disconnect the plug from the power source and/ or remove the battery pack, if detachable, from the power tool before making any adjustments, changing accessories, or storing power tools.**
Such preventive safety measures reduce the risk of starting the power tool accidentally.
 - d) **Store idle power tools out of the reach of children and do not allow persons unfamiliar with the power tool or these instructions to operate the power tool.**
Power tools are dangerous in the hands of untrained users.
 - e) **Maintain power tools and accessories. Check for misalignment or binding of moving parts, breakage of parts and any other condition that may affect the power tool's operation. If damaged, have the power tool repaired before use.**
Many accidents are caused by poorly maintained power tools.
 - f) **Keep cutting tools sharp and clean.**
Properly maintained cutting tools with sharp cutting edges are less likely to bind and are easier to control.
 - g) **Use the power tool, accessories and tool bits etc. in accordance with these instructions, taking into account the working conditions and the work to be performed.**
Use of the power tool for operations different from those intended could result in a hazardous situation.
 - h) **Keep handles and grasping surfaces dry, clean and free from oil and grease.**

Slippery handles and grasping surfaces do not allow for safe handling and control of the tool in unexpected situations.

5) Service

- a) **Have your power tool serviced by a qualified repair person using only identical replacement parts.**

This will ensure that the safety of the power tool is maintained.

PRECAUTION

Keep children and infirm persons away.

When not in use, tools should be stored out of reach of children and infirm persons.

SAFETY INSTRUCTIONS FOR MITER SAW

1. **Miter saws are intended to cut wood or wood-like products, they cannot be used with abrasive cut-off wheels for cutting ferrous material such as bars, rods, studs, etc.**

Abrasive dust causes moving parts such as the lower guard to jam. Sparks from abrasive cutting will burn the lower guard, the kerf insert and other plastic parts.

2. **Use clamps to support the workpiece whenever possible. If supporting the workpiece by hand, you must always keep your hand at least 100 mm from either side of the saw blade. Do not use this saw to cut pieces that are too small to be securely clamped or held by hand.**

If your hand is placed too close to the saw blade, there is an increased risk of injury from blade contact.

3. **The workpiece must be stationary and clamped or held against both the fence and the table. Do not feed the workpiece into the blade or cut "freehand" in any way.**

Unrestrained or moving workpieces could be thrown at high speeds, causing injury.

4. **Push the saw through the workpiece. Do not pull the saw through the workpiece. To make a cut, raise the saw head and pull it out over the workpiece without cutting, start the motor, press the saw head down and push the saw through the workpiece.**

Cutting on the pull stroke is likely to cause the saw blade to climb on top of the workpiece and violently throw the blade assembly towards the operator.

5. **Never cross your hand over the intended line of cutting either in front or behind the saw blade.**

Supporting the workpiece "cross handed" i.e. holding the workpiece to the right of the saw blade with your left hand or vice versa is very dangerous.

6. **Do not reach behind the fence with either hand closer than 100 mm from either side of the saw blade, to remove wood scraps, or for any other reason while the blade is spinning.**

The proximity of the spinning saw blade to your hand may not be obvious and you may be seriously injured.

7. **Inspect your workpiece before cutting. If the workpiece is bowed or warped, clamp it with the outside bowed face toward the fence. Always make certain that there is no gap between the workpiece, fence and table along the line of the cut.**

Bent or warped workpieces can twist or shift and may cause binding on tile spinning saw blade while cutting. There should be no nails or foreign objects in the workpiece.

8. **Do not use the saw until the table is clear of all tools, wood scraps, etc., except for the workpiece.**

Small debris or loose pieces of wood or other objects that contact the revolving blade can be thrown with high speed.

9. **Cut only one workpiece at a time.**

Stacked multiple workpieces cannot be adequately clamped or braced and may bind on the blade or shift during cutting.

10. **Ensure the miter saw is mounted or placed on a level, firm work surface before use.**

A level and firm work surface reduces the risk of the miter saw becoming unstable.

11. **Plan your work. Every time you change the bevel or miter angle setting, make sure the adjustable fence is set correctly to support the workpiece and will not interfere with the blade or the guarding system.**

Without turning the tool "ON" and with no workpiece on the table, move the saw blade through a complete simulated cut to assure there will be no interference or danger of cutting the fence.

12. **Provide adequate support such as table extensions, saw horses, etc. for a workpiece that is wider or longer than the table top.**

Workpieces longer or wider than the miter saw table can tip if not securely supported. If the cut-off piece or workpiece tips, it can lift the lower guard or be thrown by the spinning blade.

13. **Do not use another person as a substitute for a table extension or as additional support.**

Unstable support for the workpiece can cause the blade to bind or the workpiece to shift during the cutting operation pulling you and the helper into the spinning blade.

14. **The cut-off piece must not be jammed or pressed by any means against the spinning saw blade.**

If confined, i.e. using length stops, the cut-off piece could get wedged against the blade and thrown violently.

15. **Always use a clamp or a fixture designed to properly support round material such as rods or tubing.**

Rods have a tendency to roll while being cut, causing the blade to "bite" and pull the work with your hand into the blade.

16. **Let the blade reach full speed before contacting the workpiece.**

This will reduce the risk of the workpiece being thrown.

17. **If the workpiece or blade becomes jammed, turn the miter saw off. Wait for all moving parts to stop and disconnect the plug from the power source and/or remove the battery pack. Then work to free the jammed material.**

Continued sawing with a jammed workpiece could cause loss of control or damage to the miter saw.

18. **After finishing the cut, release the switch, hold the saw head down and wait for the blade to stop before removing the cut-off piece.**

Reaching with your hand near the coasting blade is dangerous.

19. **Hold the handle firmly when making an incomplete cut or when releasing the switch before the saw head is completely in the down position.**

The braking action of the saw may cause the saw head to be suddenly pulled downward, causing a risk of injury.

PRECAUTIONS ON USING SLIDE COMPOUND MITER SAW

1. Keep the floor area around the machine level. Well maintained and free of loose materials e.g. chips and cut-offs.
2. Provide adequate general or localized lighting.
3. Do not use power tools for applications other than those specified in the handling instructions.
4. Repairing must be done only by authorized service facility. Manufacturer is not responsible for any damages and injuries due to the repair by the unauthorized persons as well as the mishandling of the tool.
5. To ensure the designed operational integrity of power tools, do not remove installed covers or screws.
6. Do not touch movable parts or accessories unless the power source has been disconnected.
7. Use your tool at lower input than specified on the nameplate; otherwise, the finish may be spoiled and working efficiency reduced due to motor overload.
8. Do not wipe plastic parts with solvent. Solvents such as gasoline, thinner, benzene, carbon tetrachloride, alcohol, may damage and crack plastic parts. Do not wipe them with such solvent. Clean plastic parts with a soft cloth lightly dampened with soapy water.
9. Use only original HiKOKI replacement parts.
10. This tool should only be disassembled for replacement of carbon brushes.
11. Never cut ferrous metals or masonry.
12. Adequate general or localized lighting is provided. Stock and finished workpieces are located close to the operators normal working position.
13. Wear suitable personal protective equipment when necessary, this could include:
Hearing protection to reduce the risk of induced hearing loss.
Eye protection to reduce the risk of injuring an eye.
Respiratory protection to reduce the risk of inhalation of harmful dust.
Gloves for handling saw blades (saw blades shall be carried in a holder wherever practicable) and rough material.
14. The operator is adequately trained in the use, adjustment and operation of the machine.
15. Refrain from removing any cut-offs or other parts of the workpiece from the cutting area whilst the machine is running and the saw head is not in the rest position.
16. Never use the slide compound miter saw with its lower guard locked in the open position.
17. Ensure that the lower guard moves smoothly.
18. Do not use the saw without guards in position, in good working order and properly maintained.
19. Use correctly sharpened saw blades. Observe the maximum speed marked on the saw blade.
20. Do not use saw blades which are damaged or deformed.
21. Do not use saw blades manufactured from high speed steel.
22. Use only saw blades recommended by HiKOKI.
23. The saw blades should be 305 mm external diameter.
24. Select the correct saw blade for the material to be cut.
25. Never operate the slide compound miter saw with the saw blade turned upward or to the side.
26. Ensure that the workpiece is free of foreign matter such as nails.
27. Replace the table insert when worn.
28. Do not use the saw to cut other than aluminium, wood or similar materials.
29. Do not use the saw to cut other materials than those recommended by the manufacturer.
30. Blade replacement procedure, including the method for repositioning and a warning that this must be carried out correctly.
31. Connect the slide compound miter saw to a dust collecting device when sawing wood.
32. Take care when slotting.
33. When transporting or carrying the tool, do not grasp the holder. Grasp the handle instead of the holder.
34. Start cutting only after motor revolution reaches maximum speed.
35. Promptly cut OFF the switch when abnormality observed.
36. Shut off power and wait for saw blade to stop before servicing or adjusting tool.
37. During a miter or bevel cut the blade should not be lifted until it has stopped rotation completely.
38. During slide cutting operation, the saw must be pushed and slid away from the operator.
39. Take all the possibility of residual risks in cutting operation into your consideration, such as the inadvertent access to moving parts on slide mechanical parts on machine and so on.
40. Ensure before each cut that the machine is stable.
41. Do not stand in a line with the saw blade in front of the machine. Always stand aside of the saw blade. This protects your body against possible kickback. Keep hands, fingers and arms away from the rotating saw blade.
Do not cross your arms when operating the tool arm.
42. If the saw blade should become jammed, switch the machine off and hold the workpiece until the saw blade comes to a complete stop. To prevent kickback, the workpiece may not be moved until after the machine has come to a complete stop.
Correct the cause for the jamming of the saw blade before restarting the machine.
43. When the saw head is in the down position, never release the hand that is gripping the handle.
Doing so could snap the saw head up, forcing the tool to fall and possibly cause injury.
44. Make sure to securely hold the tool during operation. Failure to do so can result in accidents or injuries. (Fig. 2)
45. Do not look directly into the light. Such actions could result in eye injury.
Wipe off any dirt or grime attached to the lens of the LED light with a soft cloth, being careful not to scratch the lens.
Scratches on the lens of the LED light can result in decreased brightness.

NAMES OF PARTS

The numbers in the list below correspond to **Fig. 1–Fig. 36**.

1	Switch handle
2	Gear case
3	Brush cap
4	Motor head
5	Name plate
6	Motor ass'y
7	Dust bag
8	Left hex. 10 mm socket bolt
9	Locking pin

10	Holder (A)
11	Hinge
12	Indicator (For bevel scale)
13	Set pin (A)
14	Sub fence (B)
15	Fence (B)
16	Base
17	Vise assembly
18	6 mm machine screw
19	Miter scale
20	Indicator (For miter scale)
21	Bevel lock handle
22	Miter lock handle
23	Detent lever
24	Positive stop lever
25	Turntable
26	5 mm machine screw
27	4 mm screw
28	Table insert
29	Fence (A)
30	Sub fence (A)
31	Lower guard
32	Saw blade
33	Rotation direction
34	LED light
35	Trigger switch
36	Spindle lock
37	Holder
38	Slide securing knob
39	Carry handle
40	LED light switch
41	Work bench
42	8 mm nut
43	25 mm thick work bench
44	8 mm bolt
45	6 mm bolt
46	Support bar
47	Dust port
48	Steel square

49	8 mm set screw (For left 45° bevel angle)
50	8 mm set screw (For right angle)
51	8 mm set screw (For right 45° bevel angle)
52	8 mm depth adjustment bolt
53	5 mm machine screw
54	6 mm wing bolt
55	Fence
56	Line
57	Warning sign
58	Knob
59	Screw holder
60	Hex. socket set screw
61	Vise shaft
62	Workpiece
63	Vise plate
64	Marking (pre-marked)
65	Press down
66	6 mm nut
67	Auxiliary board
68	6 mm flat hd. screw
69	6 mm depth adjustment bolt
70	Loosen
71	Tighten
72	6 mm knob bolt (Optional accessory)
73	Holder (Optional accessory)
74	Steel square
75	6 mm wing nut (Optional accessory)
76	Height adjustment bolt 6 mm (Optional accessory)
77	Base surface
78	Stopper (Optional accessory)
79	6 mm wing bolt (Optional accessory)
80	Crown molding vise ass'y (Optional accessory)
81	6 mm knob bolt
82	Crown molding stopper (L) (Optional accessory)
83	Crown molding stopper (R) (Optional accessory)
84	Crown molding
85	Bottom line of the groove
86	Dust extractor







English



87	Hose (id 38 mm)
88	Adapter (Dust extractor's standard accessory)
89	Joint (C) (Optional accessory)
90	Dust collection adapter (Optional accessory)
91	Hose band (Optional accessory)
92	Duct
93	Washer (B)
94	8 mm hex. bar wrench
95	Washer (A)
96	Base grip
97	Piece of wood to secure the vise
98	Wear limit line
99	No. of carbon brush
100	Groove
101	Air gun
102	Dust guide
103	Mounting position of the sub fence (A)
104	Mounting position of the sub fence (B)

SYMBOLS

WARNING

The following show symbols used for the machine. Be sure that you understand their meaning before use.

	C12RSH3: Slide Compound Miter Saw
	To reduce the risk of injury, user must read instruction manual.
V	Rated voltage
	Switching ON
	Switching OFF
	Disconnect mains plug from electrical outlet
	Always wear eye protection.
	Always wear hearing protection.

	Do not stare at operating lamp.
	Warning
	Double insulation safety design

STANDARD ACCESSORIES

- 305 mm TCT Saw blade (mounted on tool) (For India)..... 1
- Dust bag..... 1
- 8 mm hex. bar wrench..... 1
- Vise Assembly 1
- Holder 1
- Sub Fence (mounted on tool)..... 1

Standard accessories are subject to change without notice.

APPLICATIONS

Cutting various types of aluminium sash and wood.

SPECIFICATIONS

1. Power tool

Model	C12RSH3	
Voltage (by area)*1	110 V ~	
Power Input*1	1520 W	
Saw Blade Dimensions (oD x iD x Thickness) (For India)	305 mm x 25.4 mm x 2.3 mm	
No-load speed	4000 /min	
Miter sawing range	Left 0°–45° Right 0°–57°	
Bevel sawing range	Left 0°–45° Right 0°–45°	
Compound sawing range	Left (Bevel) 0°–45°	Left (Miter) 0°–45°, Right (Miter) 0°–45°
	Right (Bevel) 0°–45°	Right (Miter) 0°–45°, Left (Miter) 0°–45°
LED light	Yes	
Machine Dimensions (Width x Depth x Height)	655 mm x 873 mm x 724 mm	
Net weight	24.3 kg	

*1 Be sure to check the nameplate on product as it is subject to change by areas.

Table 1: Max. sawing dimension

	Head	Turntable	Max. sawing dimension		
			Max. height	Max. width	With aux. board
Miter	0	0	107 mm	312 mm	-
			*120 mm	260 mm	25 mm
		Left 45° or Right 45°	107 mm	220 mm	-
			*120 mm	180 mm	25 mm
		Right 57°	107 mm	170 mm	-
			*120 mm	130 mm	25 mm
Bevel	Left 45°	0	70 mm	312 mm	-
			*75 mm	260 mm	25 mm
	Right 45°	0	45 mm	312 mm	-
			*50 mm	260 mm	25 mm
Compound	Left 45°	Left 45°	70 mm	220 mm	-
			*75 mm	180 mm	25 mm
		Right 45°	70 mm	220 mm	-
			*75 mm	180 mm	25 mm
	Right 45°	Left 45°	45 mm	220 mm	-
			*50 mm	180 mm	25 mm
Right 45°	Right 45°	45 mm	220 mm	-	
		*50 mm	180 mm	25 mm	

When cutting the workpiece which has the dimension of "**** there might be some possibility of the lower end of the circular saw to touch with the workpiece, even if the motor head is located at the lower limit position. Pay attention when cutting the workpiece. For further details, refer to "PRACTICAL APPLICATIONS" on page 19. Mount the auxiliary board on the fence surface Refer to "6. Cutting large workpieces" on page 19 (Fig. 21).

- Minimum size of the workpiece
All workpieces that can be clamped left or right from the saw blade with the supplied vise assembly.
107 × 107 mm (length × width)
- Maximum cutting depth
107 – 120 mm (Miter 0° × Bevel 0°)

PRIOR TO OPERATION

WARNING

Make all necessary adjustments before inserting the plug in the power source.

- Power source**
Ensure that the power source to be utilized conforms to the power requirements specified on the product nameplate.
Do not use with direct current, or transformers such as boosters. Doing so may result in damage or accidents.
- Power switch**
Ensure that the power switch is in the OFF position. If the plug is connected to a receptacle while the trigger switch is in the ON position, the power tool will start operating immediately, inviting serious accident.

3. Extension cord

When the work area is removed from the power source, use an extension cord of sufficient thickness and rated capacity. The extension cord should be kept as short as practicable.

- Remove all packing materials attached or connected to the tool before attempting to operate it.**

5. Installation (Fig. 3)

Ensure that the machine is always fixed to bench. Attach the power tool to a level, horizontal work bench. Select 8 mm diameter bolts suitable in length for the thickness of the work bench.

Bolt length should be at least 40 mm plus the thickness of the work bench.

For example, use 8 mm × 65 mm bolts for a 25 mm thick work bench.

6. Base holder adjustment (Fig. 4)

Loosen the 6 mm bolt with the 10 mm box wrench.

Adjust the base holder until its bottom surface contacts the bench or the floor surface.

After adjustment, firmly tighten the 6 mm bolt.

7. Releasing the locking pin (Fig. 5)

When the power tool is prepared for shipping, its main parts are secured by a locking pin.

Press the handle slightly down and pull out the locking pin to disengage the cutting head.

During transport, lock the locking pin into the gear case.

8. Installing the dust bag, stopper and vises (The stopper is an optional accessory.)

(1) Installing the dust bag (Fig. 6)

Install the dust bag onto the dust port on the miter saw. Fit the connecting tube of dust bag and the dust port together.

To empty the dust bag, pull out the dust bag assembly from dust port. Open zipper on underside of bag and empty into waste container. **Check frequently and empty the dust bag before it gets full.**

When bevel angle cutting, adjust the support bar and install the dust bag so that it hangs down vertically.

WARNING

Do not use this saw to cut and/or sand metals. The hot chips or sparks may ignite saw dust from the bag material.

CAUTION

- Empty the dust bag frequently to prevent the duct and the lower guard from becoming clogged.
Sawdust will accumulate more quickly than normal during bevel cutting.
- After cutting wood, before starting to cut aluminum window sash, discard the chips that are in the dust bag. (Attach the vise assembly as shown in Fig. 1 and also stopper as shown in Fig. 18.)

9. Check the lower guard for proper operation (Fig. 34)

WARNING

NEVER OPERATE THE POWER TOOL if the lower guard does not function smoothly.

Lower guard is designed to protect the operator from coming into contact with the saw blade during operation of the tool.

Always check that the lower guard moves smoothly and covers the saw blade properly.

10. Oblique angle

WARNING

When changing the oblique angle, hold down the motor head. If the motor head moves to an oblique angle suddenly, it may result in injury or damage to the main body.

Before the power tool is shipped from the factory, it is adjusted for 0°, right angle, left 45° bevel cutting angle

English

and right 45° bevel cutting angle with the 8 mm set screws.

When changing the adjustment, change the height of the 8 mm set screws by turning them. (Fig. 7-a, Fig. 7-b)

When changing the bevel angle to the left 45°, loosen the 6 mm wing bolt shown in Fig. 11, then slide the sub fence (B) outward and incline the motor head to the left. To change the bevel angle to the right at 45°, move the sub fence (A) outward and loosen the bevel lock handle, then pull out the set pin (A) toward the front, and tilt the motor head to the right. (Fig. 7-b)

When the motor head is straight upright, the set pin (A) is held tightly in place, so tilt the motor head slightly to the left when pulling out the set pin (A) before tilting the motor head to the right.

When adjusting the motor head to 0°, always return the set pin (A) to its initial position as shown in Fig. 7-b.

11. Checking the saw blade lower limit position

Check that the saw blade can be lowered 9 mm to 11 mm below the table insert.

When you replace a saw blade with a new one, adjust the lower limit position so that the saw blade will not cut the turntable or complete cutting cannot be done.

To adjust the lower limit position of the saw blade, follow the procedure (1) indicated below. (Fig. 8)

Furthermore, when changing the position of a 8 mm depth adjustment bolt that serves as a lower limit position stopper of the saw blade.

- (1) Turn the 8 mm depth adjustment bolt, change the height where the bolt head and the hinge contacts, and adjust the lower limit position of the saw blade.

NOTE

Confirm that the saw blade is adjusted so that it will not cut into the turntable.

PRIOR TO CUTTING

1. Positioning the table insert (Fig. 9)

Table inserts are installed on the turntable. When shipping the tool from the factory, the table inserts are so fixed that the saw blade does not contact them. The burr of the bottom surface of the workpiece is remarkably reduced, if the table insert is fixed so that the gap between the side surface of the table insert and the saw blade will be minimum. Before using the tool, eliminate this gap in accordance with the following procedure.

(1) Right angle cutting

Loosen the three 5 mm machine screws, then secure the left side table insert and temporarily tighten the 5 mm machine screws of both ends. Then fix a workpiece (about 200 mm wide) with the vise assembly and cut it off. After aligning the cutting surface with the edge of the table insert, securely tighten the 5 mm machine screws of both ends. Remove the workpiece and securely tighten the 5 mm center machine screw. Adjust the right hand table insert in the same way.

(2) Left and right bevel angle cutting

Adjust the table insert in the manner same procedure for right angle cutting.

CAUTION

After adjusting the table insert for right angle cutting, the table insert will be cut to some extent if it is used for bevel angle cutting.

When bevel cutting operation is required, adjust the table insert for bevel angle cutting.

2. Confirmation for use of sub fence (A) (Fig. 10)

WARNING

When right bevel angle cutting, loosen the 6 mm wing bolt, then slide the sub fence (A) outward and remove it. Failure to do so may result in the main body or saw blade coming into contact with the sub fence (A) and causing injury.

This power tool is equipped with a sub fence (A). In the case of direct angle cutting and left bevel angle cutting, use the sub fence (A). Then, you can realize stable cutting of the material with a wide back face.

CAUTION

In the case of direct angle cutting and left bevel angle cutting, slide inward to the position where the sub fence (A) hits, and secure it with 6 mm wing bolt. (as shown in Fig. 10)

3. Confirmation for use of sub fence (B) (Fig. 11)

WARNING

When left bevel angle cutting, loosen the 6 mm wing bolt, then slide the sub fence (B) outward. Failure to do so may result in the main body or saw blade coming into contact with the sub fence (B) and causing injury.

This power tool is equipped with a sub fence (B). In the case of direct angle cutting and right bevel angle cutting, use the sub fence (B). Then, you can realize stable cutting of the material with a wide back face.

CAUTION

In the case of direct angle cutting and right bevel angle cutting, slide inward to the position where the sub fence (B) hits, and secure it with 6 mm wing bolt. (as shown in Fig. 11)

4. Slide carriage system (Fig. 12)

WARNING

To reduce the risk of injury, return slide carriage to the full rear position after each crosscut operation.

For chop cutting operations on small workpieces, slide the cutting head assembly completely toward the rear of the unit and tighten the slide securing knob. To cut wide boards up to 312 mm, the slide securing knob must be loosened to allow the cutting head slide freely.

5. Miter scale adjustment

- Down the head and insert the locking pin.

Unlock the miter lock handle and swing the turntable until the positive stop locks it at the 0° miter position. Do not lock the miter lock handle. Place a square against the saw's fence and blade, as shown in Fig. 13. (Do not touch the tips of the blade teeth with the square. To do so will cause an inaccurate measurement.)

If the saw blade is not exactly perpendicular to the fence, loosen the 6 mm machine screws (4 pcs.) that hold the miter scale and move the miter lock handle and the scale left or right until the blade is perpendicular to the fence, as measured with the square.

Retighten the 6 mm machine screws (4 pcs.). (Fig. 13) Pay no attention to the reading of the indicator (for miter scale) at this time.

- Indicator (for miter scale) adjustment

Unlock the miter lock handle to move the turntable to the 0° position. With the miter lock handle unlocked, allow the positive stop to snap into place as you rotate the turntable to 0°.

Observe the indicator (for miter scale) and miter scale as shown in Fig. 13. If the indicator (for miter scale) does not indicate exactly 0° loosen the 4 mm screw holding the indicator (for miter scale). In place reposition the indicator (for miter scale) and tighten the 4 mm screw.

6. Miter angle adjustment

The slide compound miter saw scale can be easily read, showing miter angles from 0° to 45° to the left and right. The miter saw table has nine of the most common angle settings with positive stops at 0°, 15°, 22.5°, 31.6°, and 45°. These positive stops position the blade at the desired angle quickly and accurately. Follow the process below for quickest and most accurate adjustments. (Fig. 14)

Adjusting miter angles:

- (1) Push up the miter lock handle to release the turntable.
- (2) Push down the positive stop lever until the detent lever catches on it to release the "positive stop".
- (3) Rotate the turntable and set the indicator to line up with the desired angle of the miter scale. At this time, when using the positive stop function, pull the detent lever in the direction of the arrow near the desired angle as shown in Fig. 14, release the detent lever, and move the turntable to secure it in place at the desired angle via the positive stop function. (0°, 15°, 22.5°, 31.6°, and 45°)
- (4) Push down the miter lock handle to secure the turntable in place.

Detent lever (Fig. 14)

The detent lever allows for the table to be micro adjusted, disengaging the positive detent stops feature. When a required miter angle is close to a positive detent stop, this detent lever prevents the wedge on the positive stop lever from slipping into that detent slot on the base.

7. LED lighting system (Fig. 15) [XACT CUT LED™]

CAUTION

Do not stare at operating lamp. Staring into the light beam may result in serious injury or vision loss.

The LED lighting system [XACT CUT LED™] casts the shadow of the blade onto the workpiece. This results in greater accuracy of cuts and requires no adjustments. To use this feature, turn the LED light switch on. Bring the motor head down so the blade is approximately 6 mm from the workpiece. The shadow of the blade will be projected onto the workpiece, indicating where the blade teeth will make contact as the cut is made.

PRACTICAL APPLICATIONS

WARNING

- To avoid personal injury, never remove or place a workpiece on the table while the tool is being operated.
- Never place your limbs inside of the line next to warning sign while the tool is being operated (see Fig. 16). This may cause hazardous conditions.

CAUTION

- It is dangerous to remove or install the workpiece while the saw blade is turning.
- When sawing, clean off the shavings from the turntable.
- If the shavings accumulate too much, the saw blade from the cutting material will be exposed. Never subject your hand or anything else to go near the exposed blade.

1. Switch operation

Pulling the trigger turns the switch on. Releasing the trigger turns the switch off. (Fig. 17)

When the switch is released, the brake is applied to the saw blade rotation and the saw blade stops.

2. Turn on the LED light

Press the LED light switch to switch the LED light.

3. Using the Vise Assembly (Standard accessory)

(Fig. 18)

WARNING

Always firmly clamp or vise to secure the workpiece to the fence; otherwise the workpiece might be thrust from the table and cause bodily harm.

CAUTION

Always confirm that the motor head does not contact the vise assembly when it is lowered for cutting. If there is any danger that it may do so, move the vise assembly to a position where it will not contact the saw blade.

- (1) The vise assembly can be mounted on the base.
- (2) Turn the upper knob and securely fix the workpiece in position (Fig. 18).

NOTE

When using the vise, make sure that the tool is free of any excessive contact when the unit is swung or slid.

4. Cutting operation

- (1) As shown in Fig. 19 the width of the saw blade is the width of the cut. Therefore, slide the workpiece to the right (viewed from the operator's position) when length ⑥ is desired, or to the left when length ③ is desired. Turn the LED light, project the shadow of the blade onto the workpiece, align the left side or right side of shadow of the blade with the ink line on the workpiece.
- (2) After turning on the switch and checking that the saw blade is rotating at maximum speed, slowly push down the handle and bring the saw blade in the vicinity of the material to be cut.
- (3) Once the saw blade contacts the workpiece, push the handle down gradually to cut into the workpiece.
- (4) After cutting the workpiece to the desired depth, turn the power tool OFF and let the saw blade stop completely before raising the handle from the workpiece to return it to the full retract position.

WARNING

- Confirm that the trigger switch is turned OFF and the power plug has been removed from the receptacle whenever the tool is not in use.
- Always turn the power off and let the saw blade stop completely before raising the handle from the workpiece. If the handle is raised while the saw blade is still rotating, the cut-off piece may become jammed against the saw blade causing fragments to scatter about dangerously.
- Every time one cutting of deep-cutting operation is finished, turn the switch off, and check that the saw blade has stopped. Then raise the handle, and return it to the full retract position.
- Be absolutely sure to remove the cut material from the top of the turntable, and then proceed to the next step.
- Continued cutting operation can result in overload of the motor. Touch the motor and if it's hot, stop your cutting operation at once and rest for 10 minutes or so, and then restart your cutting operation.

CAUTION

- For maximum dimensions for cutting, refer to "SPECIFICATIONS" table.
- Increased pressure on the handle will not increase the cutting speed. On the contrary, too much pressure may result in overload of the motor and/or decreased cutting efficiency.

5. Cutting narrow workpieces (Press cutting) (Fig. 20)

Slide the hinge down to holder (A), then tighten the slide securing knob. Lower the handle to cut the workpiece. Using the power tool this way will permit cutting of workpieces of up to 107 mm square.

6. Cutting large workpieces (Fig. 21)

There may be case when a complete cutting cannot be done depending on the height of workpiece. In this case, mount an auxiliary board with the 6 mm flat head

English

screws and the 6 mm nuts using the 7 mm holes on the fence surface (two holes on each side). Refer to "SPECIFICATIONS" for the thickness of the auxiliary board.

NOTE

When cutting a workpiece exceeding 107 mm in height in right-angle cutting or 70 mm in left bevel angle cutting or 45 mm in right bevel angle cutting, adjust the lower limit position so that the base of the motor head will not come in contact with the workpiece.

To adjust the lower limit position of the saw blade, follow the procedure (1) shown in **Fig. 22**.

- (1) Lower the motor head, and turn the 6 mm depth adjustment bolt and make adjustments so that there can be a clearance of 2 mm to 3 mm between the lower limit position of the motor head and the top of the workpiece at the saw blade's lower limit position where the head of the 6 mm depth adjustment bolt contacts the hinge.

7. Cutting wide workpieces (Slide cutting) (Fig. 23)

- (1) Workpieces up to 107 mm high and 312 mm wide: Loosen the slide securing knob, grip the handle and slide the saw blade forward. Then press down on the handle and slide the saw blade backward to cut the workpiece. This facilitates cutting of workpieces of up to 107 mm in height and 312 mm in width.
- (2) Workpieces up to 120 mm high and 260 mm wide: Workpieces of up to 120 mm in height and up to 260 mm in width can be cut in the same manner as described in paragraph 6-(1) above.

WARNING

- For slide cutting, follow the procedures. Forward slide cutting (toward the operator) is very dangerous because the saw blade could kick upward from the workpiece. Therefore, always slide the handle away from the operator.
- Always return the carriage to the full rear position after each crosscut operation in order to reduce the risk of injury.
- Never put your hand on the miter lock handle during the cutting operation because the saw blade comes close to the miter lock handle when the motor head is lowered.

CAUTION

- When cutting a workpiece of 120 mm height, adjust the lower limit position of the motor head so that the gap between the lower edge of the motor head and the workpiece will be 2 to 3 mm at the lower limit position.
- If the handle is pressed down with excessive or lateral force, the saw blade may vibrate during the cutting operation and cause unwanted cutting marks on the workpiece, thus reducing the quality of the cut. Accordingly, press the handle down gently and carefully.
- In slide cutting, gently push the handle back (rearwards) in a single, smooth operation. Stopping the handle movement during the cut will cause unwanted cutting marks on the workpiece.

8. Bevel cutting procedures (Fig. 24)

WARNING

When changing the oblique angle, hold down the motor head. If the motor head moves to an oblique angle suddenly, it may result in injury or damage to the main body.

- (1) Loosen the bevel lock handle and bevel the saw blade to the left or to the right. To change the bevel angle to the right, loosen the bevel lock handle, then pull out the set pin (A) toward the front, and tilt the motor head to the right. When the motor head is straight upright, the

set pin (A) is held tightly in place, so tilt the motor head slightly to the left when pulling out the set pin (A) before tilting the motor head to the right.

- (2) Adjust the bevel angle to the desired setting while watching the bevel angle scale and indicator, then secure the bevel lock handle.

WARNING

- Always check that the bevel lock handle is secured and the motor head is clamped. If you attempt angle cutting without clamping the motor head, then the motor head might shift unexpectedly causing injuries.
- When the workpiece is secured on the left or right side of the blade, the short cut-off portion will come to rest on the right or left side of the saw blade. Always turn the power off and let the saw blade stop completely before raising the handle from the workpiece.
- If the handle is raised while the saw blade is still rotating, the cut-off piece may become jammed against the saw blade causing fragments to scatter about dangerously. When stopping the bevel cutting operation halfway, start cutting after pulling back the motor head to the initial position.
- Starting from halfway, without pulling back, causes the lower guard to be caught in the cutting groove of the workpiece and to contact the saw blade.
- When right angle cutting, loosen the 6 mm wing bolt, then slide the sub fence (A) outward and remove it.
- When left angle cutting, loosen the 6 mm wing bolt, then slide the sub fence (B) outward.

CAUTION

When cutting a workpiece of 75 mm height in the left 45° bevel cutting position or a workpiece of 50 mm height in the right 45° bevel cutting position, adjust the lower limit position of the motor head so that the gap between the lower edge of the motor head and the workpiece will be 2 to 3 mm at the lower limit position (refer to "11. Checking the saw blade lower limit position" on page 18).

NOTE

The bevel lock handle adopts a clutch system. When contacting the bevel lock handle and the main body, pull the bevel lock handle in the direction of the arrow mark as illustrated in **Fig. 24**, and change the direction of the bevel lock handle.

9. Miter cutting procedures (Fig. 25)

- (1) Unlock the miter table by lifting up on the miter lock handle.
- (2) While lightly pressing down on the positive stop lever until it engages the detent lever, grasp the miter lock handle and rotate the table left or right to the desired angle.
- (3) Once the desired miter angle is achieved, press down on the miter lock handle to secure the table into position.
- (4) If the desired miter angle is one of the nine positive stops noted below, please see the Miter detent lever section on **Fig. 14**.
- (5) Turn the LED light on and position the workpiece on the table for pre-alignment of your cut.

CAUTION

Always check that the miter lock handle is secured and the turntable is clamped. If you attempt angle cutting without clamping the turntable, then the turntable might shift unexpectedly causing injuries.

NOTE

- Positive stops are provided at the right and left of the 0° center setting, at 15°, 22.5°, 31.6° and 45° settings. Check that the miter scale and the tip of the indicator are properly aligned.
- Operation of the saw with the miter scale and indicator out of alignment will result in poor cutting precision.

10. Compound cutting procedures

Compound cutting can be performed by following the instructions in 8 and 9 above. For maximum dimensions for compound cutting, refer to "SPECIFICATIONS" table.

CAUTION

Always secure the workpiece with the right or left hand and cut it by sliding the round portion of the saw backwards with the right or left hand.

It is very dangerous to rotate the turntable to the right or left during compound cutting because the saw blade may come into contact with the hand that is securing the workpiece.

In case of compound cutting (angle + bevel) by left bevel, slide the sub-fence (B) outward, and engage in the cutting operation.

In case of compound cutting (angle + bevel) by right bevel, remove the sub-fence (A), and engage in the cutting operation.

11. Cutting long materials

When cutting long materials, use an auxiliary platform which is the same height as the holder (optional accessory) and base of the special auxiliary equipment. Capacity:

wooden material (W × H × L)

300 mm × 45 mm × 1300 mm, or

180 mm × 25 mm × 2000 mm

12. Installing the holders ... (Optional accessory)

The holders help keep longer workpieces stable and in place during the cutting operation.

- (1) As indicated in Fig. 26, use a steel square for aligning the upper edge of the holders with the base surface. Loosen the 6 mm wing nut. Turn a height adjustment bolt 6 mm, and adjust the height of the holder.
- (2) After adjustment, firmly tighten the 6 mm wing nut and fasten the holder with the 6 mm knob bolt (optional accessory). If the length of Height Adjustment Bolt 6 mm is insufficient, spread a thin plate beneath. Make sure the end of Height Adjustment Bolt 6 mm does not protrude from the holder.

CAUTION

When transporting or carrying the tool, do not grasp the holder. There is the danger of the holder slipping out of the base. Grasp the handle instead of the holder.

13. Stopper for precision cutting ... (Stopper and holder are optional accessory)

The stopper facilitates continuous precision cutting in lengths of 285 mm to 450 mm. To install the stopper, attach it to the holder with the 6 mm knob bolt as shown in Fig. 27.

14. Confirmation for use Crown molding vise, Crown molding Stopper (L) and (R) (Optional accessory)

- (1) Crown molding Stopper (L) and (R) (optional accessories) allow easier cuts of crown molding without tilting the saw blade. Install them in the base both-sides side to be shown in Fig. 28. After inserting tighten the 6 mm knob bolts to secure the Crown molding Stoppers.
- (2) The crown molding vise (B) (Optional accessory) can be mounted on either the left fence (Fence (B)) or the right fence (Fence (A)). It can unite with the slope of the crown molding and vice can be pressed down. Then turn the upper knob, as necessary, to securely attach the crown molding in position. To raise or lower the vise assembly, first loosen the hex. socket set screw.

After adjusting the height, firmly tighten the 6 mm wing bolt; then turn the upper knob, as necessary, to securely attach the crown molding in position (Fig. 29). Position crown molding with its WALL CONTACT EDGE against the guide fence and its CEILING CONTACT EDGE against the Crown molding Stoppers

as shown in Fig. 29. Adjust the Crown molding Stoppers according to the size of the crown molding. Tighten the 6 mm wing bolt to secure the Crown molding Stoppers. Refer to the lower table for the miter angle. Use the sub fence (A) to secure the crown molding more firmly.

WARNING

Always firmly clamp or vise to secure the crown molding to the fence; otherwise the crown molding might be thrust from the table and cause bodily harm.

Do not bevel cutting. The main body or saw blade may contact the sub fence, resulting in an injury.

CAUTION

Always confirm that the motor head does not contact the crown molding vise assembly when it is lowered for cutting.

If there is any danger that it may do so, loosen the hex. socket set screw and move the crown molding vise assembly to a position where it will not contact the saw blade.

15. Groove cutting procedures

Grooves in the workpiece can be cut by adjusting the 6 mm depth adjustment bolt (Fig. 30).

- (1) Lower the motor head, and turn the 6 mm depth adjustment bolt by hand. (Where the head of the 6 mm depth adjustment bolt contacts the hinge.)
- (2) Adjust to the desired cutting depth by setting the distance between the saw blade and the surface of the base (Fig. 30).

NOTE

When cutting a single groove at either end of the workpiece, remove the unneeded portion with a chisel.

16. Connecting the dust extractor (Sold separately) (Fig. 31)

Do not inhale the harmful dusts generated in cutting operation.

The dust can endanger the health of yourself and bystanders.

Use of dust extractor can reduce dust related hazards.

By connecting with dust extractor through adapter, joint and dust collection adapter, most of dust can be collected.

Connect the dust extractor with adapter.

- (1) Connect in order of hose (id 38 mm × 3 m long) and adapter (Dust extractor's Standard accessory) joint (Optional accessory) and dust collection adapter (Optional accessory) with the duct of power tool. Connection is done by pressing in the direction of the arrow. (Fig. 31)
- The dust collection adapter (Optional accessory) is fixed to the duct by a hose band. (Optional accessory)

MOUNTING AND DISMOUNTING SAW BLADE

WARNING

To prevent an accident or personal injury, always turn off the trigger switch and disconnect the power plug from the receptacle before removing or installing a saw blade.

1. Mounting the saw blade (Fig. 32)

- (1) Press in spindle lock and loosen 10 mm bolt with 8 mm hex. bar wrench (standard accessory). Since the 10 mm bolt is left-hand threaded, loosen by turning it to the right.

NOTE

- If the spindle lock cannot be easily pressed in to lock the spindle, turn the 10 mm bolt with 8 mm hex. bar wrench (standard accessory) while applying pressure on the spindle lock.

English

- The saw blade spindle is locked when the spindle lock is pressed inward.
- (2) Remove the bolt and washer (B)
- (3) Lift the lower guard and mount the saw blade.

WARNING

When mounting the saw blade, confirm that the rotation indicator mark on the saw blade and the rotation direction of the gear case (Fig. 1) are properly matched.

- (4) Thoroughly clean washer (B) and the 10 mm bolt, and install them onto the saw blade spindle.
- (5) Press in the spindle lock and tighten the 10 mm bolt by turning it to the left by 8 mm hex. bar wrench (standard accessory).

WARNING

Tighten the 10 mm bolt so it does not come loose during operation. Confirm the 10 mm bolt has been properly tightened before the power tool is started.

CAUTION

- A dust guide is installed inside behind the hinge. When removing or installing the saw blade, do not make contact with the dust guide. Contact may break or chip saw blade tips. (Fig. 32)
- Confirm that the spindle lock has returned to the retract position after installing or removing the saw blade.

2. Dismounting the saw blade

Dismount the saw blade by reversing the mounting procedures.
The saw blade can easily be removed after lifting the lower guard.

CAUTION

Never attempt to install saw blades except 305 mm in diameter.

TRANSPORTATION OF THE MAIN BODY

WARNING

To avoid an accident or personal injury, always confirm that the trigger switch is turned OFF and remove the battery before transportation of the main body.

The vice assembly could be dropped during transportation. Either remove the assembly or slip a piece of wood between the vice to firmly secure it. (Fig. 33-b)

Down the head and insert the locking pin (see page 17 "7. Releasing the locking pin"). Also screw in the slide securing knob so that the hinge is positioned to hit the holder (A) and secure the head. (Fig. 33-a)

Lift up the miter lock handle, turn the turntable as far right as it will go, and secure the turntable by press down the miter lock handle to the fixed position. This will make the main body even more compact. (Fig. 33-b)

When transporting the main body, carry it in your arms, holding the grip located on the base with both hands.

When transporting with two people, each person should use both their hands to hold the carry handle, handle and the base grip.

MAINTENANCE AND INSPECTION

WARNING

To prevent an accident or personal injury, always turn off the trigger switch and disconnect the power plug from the receptacle or remove the battery before doing any inspection or maintenance.

1. Inspecting the saw blade

Always replace the saw blade immediately upon the first sign of deterioration or damage.
A damaged saw blade can cause personal injury and a worn saw blade can cause ineffective operation and possible overload to the motor.

CAUTION

Never use a dull saw blade. When a saw blade is dull, its resistance to the hand pressure applied by the tool handle tends to increase, making it unsafe to operate the power tool.

2. Inspecting the mounting screws

Regularly inspect all mounting screws and ensure that they are properly tightened. Should any of the screws be loose, retighten them immediately. Failure to do so could result in serious hazard.

3. Inspecting the carbon brushes (Fig. 35)

The motor employs carbon brushes which are consumable parts. Since an excessively worn carbon brush can result in motor trouble, replace the carbon brushes with new ones having the same carbon brush No. shown in the figure when it becomes worn to or near the "wear limit". In addition, always keep carbon brushes clean and ensure that they slide freely within the brush holders.

4. Replacing a carbon brushes (Fig. 35)

Disassemble the brush cap with a slotted-head screwdriver. The carbon brushes can then be easily removed.

5. Maintenance of the motor

The motor unit winding is the very "heart" of the power tool. Exercise due care to ensure the winding does not become damaged and/or wet with oil or water.

6. Inspecting the lower guard for proper operation

- Before each use of the tool, test the lower guard (Fig. 34) to assure that it is in good condition and that it moves smoothly.
- Never use the tool unless the lower guard operates properly and it is in good mechanical condition.

7. Lubrication

Lubricate the following sliding surfaces once a month to keep the power tool in good operating condition for a long time.

Use of machine oil is recommended.

Oil supply points:

- Rotary portion of hinge
- Rotary portion of holder (A)
- Rotary portion of vise assembly

8. Cleaning

Clean the machine, duct and lower guard by blowing with dry air from an air gun or other tool. (Fig. 36)
Periodically remove chips and other waste material from the surface of the power tool with a damp, soapy cloth. To avoid a malfunction of the motor, protect it from contact with oil or water.

If the LED line becomes invisible due to chips and the like adhered onto the window of the LED's light-emitting section, wipe and clean the window with a dry cloth or a soft cloth moistened with soapy water, etc.

9. Storage

After operation of the tool has been completed, check that the following has been performed:

- (1) Trigger switch is in OFF position,
- (2) Power plug has been removed from the receptacle, When the tool is not in use, keep it stored in a dry place out of the reach of children.

SELECTING ACCESSORIES

The accessories of this machine are listed on page 38.

CAUTION

Repair, modification and inspection of HiKOKI Power Tools must be carried out by a HiKOKI Authorized Service Center.

In the operation and maintenance of power tools, the safety regulations and standards prescribed in each country must be observed.

NOTE

Due to HiKOKI's continuing program of research and development, the specifications herein are subject to change without prior notice.

TROUBLESHOOTING

Use the inspections in the table below if the tool does not operate normally. If this does not remedy the problem, consult your dealer or the HiKOKI Authorized Service Center.

Symptom	Possible cause	Remedy
Tool suddenly stopped	Tool was overburdened	Get rid of the problem causing the overburden.
	The motor was automatically stopped to prevent failure of the tool.	This is not a malfunction. The trigger switch was held down for 5 minutes or more. Switch on the power once more.
Cannot be tilted	The bevel lock handle has not been loosened.	Loosen the bevel lock handle and then tilt the tool. After adjusting the loosened component, make sure to tighten it once again.
Cannot be tilted to the right	Set pin (A) has not been pulled out.	Tilt to the right after pulling out set pin (A).
	The bevel lock handle has not been loosened.	Loosen the bevel lock handle and then tilt.
Sawblade is dull	The sawblade is worn down or missing teeth.	Exchange with a new product.
	Bolt is loose.	Tighten the bolt.
	The sawblade has been installed in reverse.	Install the sawblade in the correct direction.
Cannot cut with precision	The operation parts of the tool are not fully fixed.	Fully install the bevel lock handle and miter lock handle.
	Material cannot be fixed in the correct position.	Remove any foreign material from the fence or turntable. In some cases, proper position cannot be fixed due to a curve in the material. Try to fix a flat surface with the fence or turntable.

一般安全規則

△ 警告

閱讀所有安全警告說明

未遵守警告與說明可能導致電擊、火災或其他嚴重傷害。

請妥善保存本使用說明書，以供未來參考之用。

「電動工具」一詞在警告中，係指電源操作（有線）之電動工具或電池操作（無線）之電動工具。

1) 工作場所安全

- a) 保持工作場所清潔及明亮。
雜亂或昏暗的區域容易發生意外。
- b) 勿在易產生爆炸之環境中操作，譬如有易燃液體、瓦斯或粉塵存在之處。
電動工具產生火花會引燃粉塵或煙氣。
- c) 當操作電動工具時，確保兒童及過往人員遠離。
分神會讓您失去控制。

2) 電氣安全

- a) 電動工具插頭必須與插座配合，絕不可以任何方法修改插頭，且不得使用任何轉接插頭於有接地之電動工具。
不修改插頭及所結合之插座，可減少電擊。
- b) 避免身體接觸到地面，諸如管子、散熱器、爐灶及冰箱。
如果您的身體接地或觸地，會增加電擊的危險。
- c) 勿讓電動工具淋雨或曝露在潮濕的環境下。
電動工具進水會增加電擊的危險。
- d) 勿濫用電源線。請勿使用電源線去纏繞、拖拉電動工具或拔插頭，保持電源線遠離熱氣、油氣、尖角或可動零件。
損壞或纏繞的電源線會增加電擊之危險。
- e) 電動工具在室外操作時，請務必使用適合室外用的延長線。
使用合適之室外用延長線會減少電擊的危險。
- f) 若無法避免在潮濕地區操作電動工具，請使用以漏電斷路器 (RCD) 來保護電源。
使用 RCD，可降低觸電危險。

3) 人員安全

- a) 保持機警，注意您正在做什麼，並運用正確常識操作電動工具。當您感到疲勞或受藥品、酒精或醫療影響時，請勿操作電動工具。
操作中瞬間的不注意，可能造成人員嚴重的傷害。
- b) 使用個人防護裝備，經常配戴安全眼鏡。

配戴防塵口罩、防滑安全鞋、硬帽等防護裝備，或在適當情況下使用聽覺防護，可減少人員傷害。

- c) 防止意外發生。在連接電源或電池組、拿起或攜帶工具前，請確認開關是在「off」（關閉）的位置。
以手指放在開關握持電動工具，或在電動工具的開關於「on」的狀況下插上插頭，都會導致意外發生。
 - d) 在電動工具啟動前，先卸下任何調整用鑰匙或扳手。
扳手或鑰匙遺留在電動工具的轉動部位時，可能導致人員傷害。
 - e) 身體勿過度伸張，任何時間要保持站穩及平衡。
以便在不預期的狀態下，能對電動工具有較好的控制。
 - f) 衣著要合宜，別穿太鬆的衣服或戴首飾。保持你的頭髮、衣服及手套遠離轉動部位。
寬鬆的衣服、手飾及長髮會被捲入轉動部位。
 - g) 如果裝置要用於粉塵抽取及集塵設施，要確保其連接及正當使用。
使用集塵裝置可減少與灰塵相關的危險。
 - h) 請勿因頻繁使用本工具，熟悉操作而忽略本工具的安全原則。
粗心的行動有可能瞬間即造成嚴重傷害。
- #### 4) 電動工具之使用及注意事項
- a) 勿強力使用電動工具，使用正確之電動工具為您所需。
正確使用電動工具，會依其設計條件，使工作做得更好更安全。
 - b) 如果開關不能轉至開或關的位置，勿使用電動工具。
任何電動工具不能被開關所控制是危險的，必須要修理。
 - c) 進行任何調整、更換配件或收存電動工具時，必須將插頭與電源分開，且需將電池組從電動工具中取出。
此種預防安全措施，可減少意外開啟電動工具之危險。
 - d) 收存停用之電動工具，需遠離兒童，且不容許不熟悉電動工具或未瞭解操作電動工具說明的人操作電動工具。
在未受過訓練的人手裡，電動工具極為危險。
 - e) 保養電動工具，檢查是否可動零件有錯誤的結合或卡住、零件破裂及可能影響電動工具操作的任何其他情形。電動工具如果損壞，在使用前要修好。
許多意外皆肇因於不良的保養。
 - f) 保持切割工具銳利清潔。

適當的保養切割工具，保持銳利之切削鋒口，可減少卡住並容易控制。

- g) 按照說明書使用電動工具、配件及刀具時，必須考量工作條件及所執行之工作。
若未依照這些使用說明操作電動工具時，可能造成相關之危害情況。
 - h) 保持把手和握持面乾燥、清潔，且未沾到油脂和潤滑油。
滑溜的把手和握持面在操作時會有安全上的問題，且可能造成本工具意外失去控制。
- 5) 維修
- a) 讓您的電動工具由合格修理人員僅使用相同的維修零件更換。
如此可確保電動工具的安全得以維持。

注意事項

不可讓孩童和體弱人士靠近工作場所。
應將不使用的電動工具存放在孩童和體弱人士伸手不及的地方。

切斷機安全說明

1. 切斷機用於切割木材或類似木材的產品，不可與研磨切割砂輪一起用於切割如棒材、桿材、飾釘等的含鐵材料。
磨蝕性粉塵會導致下部安全罩等可動零件卡住。研磨切割產生的火花會燒壞下護罩、切口插件和其他塑料零件。
2. 盡可能使用夾具支撐工件。如果用手支撐工件，則必須始終將手放在距離鋸片兩側至少100 mm處。請勿使用此切斷機切割太小而無法用手夾緊或握住的碎片。
如果您的手放得離鋸片太近，刀片接觸會增加受傷的風險。
3. 工件必須固定不動，並且靠在擋板和工作台上夾緊或握住。不要以任何方式將工件送入刀片或「徒手」切割。
未被固定或移動的工件可能會以高速被拋出而造成受傷。
4. 將切斷機推向工件。不要將切斷機拉向工件。要進行切割時，請抬起鋸頭並將其拉出工件而不進行切割，啟動馬達，向下按壓鋸頭並將切斷機推向工件。
在拉動行程上切割可能會導致鋸片爬上工件頂部並猛烈地將刀片組件拋向操作人員。
5. 切勿將手伸過鋸片前方或後方的預定切割線。「手交叉」支撐工件，也就是用左手將工件握在鋸片的右側（反之亦然）是非常危險的。
6. 當鋸片正在旋轉時，不要在距離鋸片兩側100 mm以內的範圍為了移除木屑或出於任何其他原因而觸及擋板後面。

旋轉中的鋸片與手的接近可能並不明顯，而您可能會受重傷。

7. 切割前請檢查工件。如果工件彎曲或翹曲，則將外側彎曲面朝向擋板夾住。始終確保工件、擋板和沿著切割線的工作台之間沒有縫隙。
彎曲或翹曲的工件可能會扭曲或移位，並且可能在切割時導致瓷磚旋轉鋸片上卡住。工件上不應有釘子或異物。
8. 除非工作台上除了工件以外，沒有其他任何工具、木屑等，否則不要使用切斷機。
小碎片或未被固定的木片或與旋轉中的鋸片接觸的其他物體可能會被高速拋出。
9. 一次只切割一個工件。
堆疊的多個工件不能被充分地夾緊或支撐，並且可能在切割過程中卡在鋸片上或移位。
10. 使用前確保切斷機安裝或放置在水平堅固的工件表面上。
水平和堅固的工作表面降低了切斷機變得不穩定的風險。
11. 計劃作業。每次更改斜角或斜接角度設定時，請確保可調節擋板設定正確以支撐工件，並且不會干擾鋸片或防護系統。
在不「開啟」工具且工作台上沒有工件的狀態下，將鋸片移動通過完整的模擬切割，以確保不會有干擾或切割擋板的危險。
12. 為比桌面更寬或更長的工件提供足夠的支撐，例如工作台延伸裝置、鋸馬等。
如果沒有牢固地支撐，比切斷機工作台更長或更寬的工件可能會翻倒。如果切割件或工件翻倒，可能會抬起下部安全罩或被旋轉中的刀片拋出。
13. 不要使用其他人代替工作台延伸裝置或作為額外的支撐。
在切割操作過程中，對工件的不穩定支撐會導致刀片卡住或工件移位，將您和輔助人員拉入旋轉中的刀片。
14. 切割件不得用任何方法卡住或壓在旋轉中的鋸片上。
如果切割件被侷限住，也就是使用長度停止，則切割件可能會楔入刀片並猛烈地拋出。
15. 始終使用設計用於正確支撐圓形材料（如桿材或管材）的夾具或固定裝置。
桿材在切割時容易滾動，而導致刀片「咬住」並將您的手和工件拉入刀片。
16. 在接觸工件之前讓刀片達到全速。
這將降低工件被拋出的風險。
17. 如果工件或刀片卡住，請關閉切斷機。等待所有移動中的零件停止，並斷開插頭與電源的连接或取出電池組。然後釋放卡住的材料。
繼續鋸切卡住的工件可能會導致切斷機失控或損壞。
18. 完成切割後，鬆開開關，按住鋸頭並等待刀片停止，然後取下切割件。

用手靠近滑行中的刀片很危險。

19. 在鋸頭完全處於向下位置之前，在進行不完全切割或鬆開開關時，請牢牢握住手柄。
切斷機的停止動作用可能會造成鋸頭突然被向下拉，進而導致受傷的風險。

使用多角度切斷機須知

1. 機器周圍的地面應保持水平。維護良好且無鬆散的物料，如碎屑與切片。
2. 保證充足的總體或局部照明。
3. 請勿將本電動工具用於使用說明書中所規定之外的其他用途。
4. 維修僅能由有資格的維修人員進行。製造廠商對因非專業維修人員進行維修及使用不當而造成的損壞和損傷概不負責。
5. 為了保證設計的完整性，電動工具的護罩和螺釘類不可隨便拆除。
6. 除非電線插頭已從電源插座拆下，絕不可接觸轉動部分或附件。
7. 應以低於銘牌上的額定輸入功率進行作業。否則馬達將過載而影響工作精度，並降低效率。
8. 不可使用溶劑擦拭塑料零件。因為：汽油、沖淡劑、輕質汽油、四氯化碳、酒精等都會使塑料損傷或發生龜裂，所以應避免使用。不可使用溶劑擦拭塑料零件。擦拭塑料製品，可以使用稍微沾濕了肥皂水的柔布。
9. 只能使用HiKOKI指定的更換零件。
10. 本電動工具只在更換炭刷時才可拆解。
11. 切勿切割鐵金屬或磚瓦材料。
12. 提供充足的總體或局部照明。原料與成品工件應位於操作員的正常工作位置附近。
13. 必要時應使用適當的個人保護設備，可包括：
聽力保護，以減少聽力受損的風險。
眼部保護，以減少眼睛受傷的風險。
呼吸保護，以減少吸入有害灰塵的風險。
手套，用於操作鋸片(移動鋸片時應盡可能把鋸片放在支架中)以及粗糙材料。
14. 操作員應接受機器使用、調節與操作方面的充分培訓。
15. 在機器運行且鋸頭未處於停止位置時，不得從切割區域移去工件的任何切片或其他部分。
16. 多角度切斷機的下部安全罩鎖定在開啟位置時，切勿進行使用。
17. 確保下部安全罩能夠平滑地移動。
18. 安全罩未處於正常位置時請勿使用複合鋸，要在其工作狀態良好且得到正確的維護的情況下使用。
19. 使用經過正確磨快的鋸片。注意鋸片上標注的最大速度。
20. 鋸片破損或變形時請勿使用。
21. 不要使用以高速鋼材製造的鋸片。

22. 請僅使用HiKOKI公司所推薦的鋸片。
23. 鋸片的外徑應為305 mm。
24. 須根據要切割的材料來選擇鋸片。
25. 多角度切斷機的鋸片往上面或側面翹起時，切勿進行使用。
26. 確保工件上無任何異物(如鐵釘等)。
27. 導板磨損時請予更換。
28. 請勿使用鋸片切割鋁材、木材或類似材料以外的材料。
29. 請僅使用製造商所推薦的多角度切斷機切割材料。
30. 鋸片更換程序，包括重置方法以及關於務必正確進行此程序的警告。
31. 在切割木頭時，將多角度切斷機與集塵裝置相連接。
32. 開槽時要小心。
33. 在搬運此電動工具時，請勿抓住其支架。應抓住手柄而不要抓住支架。
34. 須在馬達達到最大轉速時才開始切割。
35. 發現異常情況時應迅速關閉開關。
36. 在切斷電源並等到鋸片停止之後，方可對工具進行維修或調整。
37. 在進行斜接切割或斜角切割中，在鋸片完全停止轉動之後，方能升高鋸片。
38. 進行滑動切割操作時，鋸子的推動和滑動必須遠離操作員。
39. 務必考慮切割操作中所有可能產生的風險，例如無意中接觸機器滑動機械部分的移動中零件等。
40. 確保每次切割前，機器是在穩定的狀態。
41. 不要在機器前面與鋸片站成一直線。務必站在鋸片的側邊。這樣可以保護您的身體免受可能的反彈。保持手部、手指和手臂遠離旋轉中的鋸片。操作工具臂桿時，不要交叉您的雙臂。
42. 如果鋸片卡住，請關閉機器並保持工件在原位，直到鋸片完全停止為止。為了避免反彈，直到機器已經完全停止後，不要移動工件。
重新啟動機器前，糾正鋸片卡住的原因。
43. 當鋸頭處於向下位置時，切勿鬆開握住握把的手。
否則會使鋸頭突然向上彈起，迫使工具掉落並可能造成傷害。
44. 操作時請務必牢牢地握住本工具。否則可能會導致事故或受傷。(圖 2)
45. 請勿直視燈泡。若直視，可能會導致眼睛受傷。用軟布擦去附着在LED鏡頭上的灰塵或污垢，注意不要刮傷鏡頭。
LED鏡頭上的刮痕可能會導致亮度下降。

各部位名稱

以下列表中的數字與圖 1—圖 36 相對應。

1	切換手柄	30	副擋板 (A)
2	齒輪箱	31	下罩
3	碳刷蓋	32	鋸片
4	鋸頭	33	旋轉方向
5	銘牌	34	LED燈
6	馬達組件	35	按鍵開關
7	集塵袋	36	主軸鎖
8	左內六角孔10 mm 螺栓	37	支架
9	鎖定銷	38	滑動式固定旋鈕
10	支架 (A)	39	手提握把
11	鉸鏈	40	LED燈開關
12	指針 (斜角尺用)	41	工作台
13	定位銷 (A)	42	8 mm 螺母
14	副擋板 (B)	43	25 mm厚工作台
15	擋板 (B)	44	8 mm 螺栓
16	底座	45	6 mm 螺栓
17	虎鉗組件	46	支撐桿
18	6 mm螺絲	47	集塵端口
19	斜接尺	48	方鋼
20	指針 (斜接尺用)	49	8 mm 固定螺絲 (左 45° 斜角角度用)
21	斜角鎖定手柄	50	8 mm 固定螺絲 (直角用)
22	斜接鎖定手柄	51	8 mm 固定螺絲 (右 45° 斜角角度用)
23	止動桿	52	8 mm 深度調節螺栓
24	限位擋塊桿	53	5 mm螺絲
25	回轉台	54	6 mm 翼狀螺栓
26	5 mm螺絲	55	擋板
27	4 mm螺絲	56	線條
28	導板	57	警告標誌
29	擋板 (A)		

中國語

58	旋鈕
59	螺絲支架
60	六角套筒固定螺絲
61	虎鉗軸
62	工件
63	虎鉗板
64	標誌 (預先標記)
65	向下按
66	6 mm 螺母
67	輔助板
68	6 mm 平頭螺絲
69	6 mm 深度調節螺栓
70	放鬆
71	上緊
72	6 mm 旋鈕螺栓 (選購件)
73	支架 (選購件)
74	方鋼
75	6 mm 翼狀螺母 (選購件)
76	高度調節螺栓 6 mm (選購件)
77	底座面
78	止動片 (選購件)
79	6 mm 翼狀螺栓 (選購件)
80	冠狀模塑虎鉗組件 (選購件)
81	6 mm 旋鈕螺栓
82	冠狀模塑止動片 (L) (選購件)
83	冠狀模塑止動片 (R) (選購件)
84	冠狀模塑
85	凹槽底線
86	集塵器

87	軟管 (id 38 mm)
88	適配器 (集塵器標準附件)
89	接頭 (C) (選購件)
90	集塵適配器 (選購件)
91	軟管帶 (選購件)
92	導管
93	襯墊 (B)
94	8 mm 六角棒狀扳手
95	襯墊 (A)
96	底座握把
97	固定虎鉗的木板
98	磨損極限線
99	碳刷號碼
100	凹槽
101	空氣槍
102	集塵引導器
103	副檔板 (A) 安裝位置
104	副檔板 (B) 安裝位置

符號

警告

以下為使用於本機器的符號。請確保您在使用前明白其意義。

	C12RSH3: 多角度切斷機
	使用前請詳讀使用說明書
V	額定電壓
	開關ON
	開關OFF

	從電源插座拔下主電源插頭
	經常配戴安全眼鏡
	始終配戴聽力保護裝置
	請勿凝視LED燈
	警告
	雙重絕緣安全設計

複合鋸切範圍	右 (斜角) 0° - 45°	右 (斜接) 0° - 45° , 左 (斜接) 0° - 45°
LED燈	有	
電動工具尺寸 (寬×長×高)	655 mm × 873 mm × 724 mm	
淨重	24.3 kg	

*1 請務必檢查產品上的銘牌，因其可能會依地區而有所變更。

表 1: 最大切鋸尺寸

	頭	回轉台	最大切鋸尺寸		
			最大高度	最大寬度	含輔助板
斜接	0	0	107 mm	312 mm	-
			*120 mm	260 mm	25 mm
		左 45° 或 右 45°	107 mm	220 mm	-
			*120 mm	180 mm	25 mm
		右 57°	107 mm	170 mm	-
			*120 mm	130 mm	25 mm
斜角	左 45°	0	70 mm	312 mm	-
			*75 mm	260 mm	25 mm
	右 45°	0	45 mm	312 mm	-
			*50 mm	260 mm	25 mm
複合	左 45°	左 45°	70 mm	220 mm	-
			*75 mm	180 mm	25 mm
		右 45°	70 mm	220 mm	-
			*75 mm	180 mm	25 mm
	右 45°	左 45°	45 mm	220 mm	-
			*50 mm	180 mm	25 mm
	右 45°	右 45°	45 mm	220 mm	-
			*50 mm	180 mm	25 mm

標準附件

- 集塵袋..... 1
- 8 mm 六角棒狀扳手 1
- 虎鉗組件 1
- 支架 1
- 副擋板 (安裝在電動工具上) 1

標準配件可能不預先通告而徑予更改。

用途

切割各種類型的鋁框格和木材。

規格

1. 電動工具

機型	C12RSH3	
電壓 (依地區) *1	110 V ~	
電源輸入*1	1520 W	
無負載速度	4000 /min	
斜接鋸切範圍	左 0° - 45° 右 0° - 57°	
斜角鋸切範圍	左 0° - 45° 右 0° - 45°	
複合鋸切範圍	左 (斜角) 0° - 45°	左 (斜接) 0° - 45° , 右 (斜接) 0° - 45°

中國語

當切割具有“*”尺寸的工件時，即使鋸頭位於下限位置，圓鋸的下端仍有可能與工件接觸。切割工件時請小心。有關詳細內容，請參閱第19頁的「實際應用」。將輔助板安裝在擋板表面。請參閱第19頁（圖 21）上的「6. 切割大型工件」

1. 工件最小尺寸
所有可以使用隨附的虎鉗組件從鋸條向左或向右夾持的工件。
107 × 107mm (長×寬)
2. 最大切割深度
107 - 120 mm (斜接 0° × 斜角 0°)

操作前

警告

在將插頭插入電源之前進行所有必要的調整。

1. 電源
確認所使用的電源與本產品銘牌上指定的電源必要條件是否相符。
請勿使用直流電，或如升壓器等的變壓器。否則可能會造成損壞或意外事故。
2. 電源開關
確保電源開關處於OFF位置。如果在扳機開關處於ON位置時插頭被連接到插座，電動工具將立即開始運作而導致嚴重的事務。
3. 延長線
若作業場所移至離開電源的地點，請使用足夠厚度和額定容量的延長線。延長線應盡可能地短些。
4. 在嘗試操作之前，請移除所有附著或連接到工具的包裝材料。
5. 安裝（圖 3）
確保將切斷機始終固定在工作臺上。
將電動工具安裝到水平的工作臺上。
選擇適合工作臺厚度的8 mm直徑螺栓。
螺栓長度至少應為40 mm加上工作臺厚度。
例如，對於25 mm厚的工作臺，應使用8 mm × 65 mm的螺栓。
6. 底座支架調節（圖 4）
用10 mm套筒扳手鬆開6 mm螺栓。調整底座支架，直到其底部表面接觸工作臺或地板表面。
調節後，旋緊6 mm螺栓。
7. 釋放鎖定銷（圖 5）
當電動工具準備要出貨時，其主要零件由鎖定銷固定。
稍微向下按手柄並拉出鎖定銷以鬆開切割頭。
運輸期間，請將鎖定銷插入齒輪箱鎖定。
8. 安裝集塵袋、止動片和虎鉗（止動片為選購件。）
 - (1) 安裝集塵袋（圖 6）
將集塵袋安裝在斜鋸機的集塵袋口上。
將集塵袋的連接管和集塵袋口安裝在一起。

若要清空集塵袋，請從集塵袋口拉出集塵袋組件。打開袋子底部的拉鍊，並倒入垃圾桶中。經常檢查並在集塵袋變滿之前將其清空。
進行斜角切割時，調整支撐桿並安裝集塵袋，使其垂直地垂下。

警告

不要使用本切斷機切割或磨光金屬。熱碎片或火花可能會點燃來自袋子中的鋸屑。

注意

- 經常清空集塵袋，以防止導管和下部安全罩堵塞。
在斜角切割過程中，木屑會比平常更快地積累。
- 切割木材後，在開始切割鋁窗扇之前，請丟棄集塵袋中的鋸屑。
(如圖 1 所示安裝虎鉗組件，並如圖 18 所示安裝止動片。)

9. 檢查下部安全罩是否正常運作（圖 34）

警告

如果下部安全罩不能流暢運作，切勿操作本電動工具。
下部安全罩是設計用於保護操作人員在工具運作期間不與鋸片接觸。
務必檢查下部安全罩是否移動流暢並正確覆蓋鋸片。

10. 傾斜角

警告

變更傾斜角度時，按住馬達頭。如果馬達頭突然移動到傾斜角度，可能會導致受傷或主機體損壞。

本電動工具從工廠出貨時，以 8 mm 固定螺絲調整為 0°、直角、左側 45° 斜角切割角度和右側 45° 斜角切割角度。

變更調整時，可透過轉動 8 mm 固定螺絲來改變其高度。（圖 7-a、圖 7-b）

將斜角變更為左側 45° 時，請鬆開如圖 11 所示的 6 mm 翼狀螺栓，然後向外滑動副擋板（B）並使馬達頭向左傾斜。

若要將斜角角度變更為右側 45°，請向外移動副擋板（A）並鬆開斜角鎖定手柄，然後向前拉出定位銷（A），並將馬達頭向右傾斜。（圖 7-b）當馬達頭直豎時，定位銷（A）被牢固地固定到位，因此在拉出定位銷（A）時，請先將馬達頭稍微向左傾斜，然後再將馬達頭向右傾斜。
將馬達頭調整為 0° 時，務必將定位銷（A）返回到原來的位，如圖 7-b 所示。

11. 檢查鋸片下限位置

檢查鋸片是否可以降低到導板下方 9 mm 至 11 mm。

當您更換新的鋸片時，請調整下限位置，使鋸片不會切割到回轉台，否則將完全無法切割。
要調整鋸片的下限位置時，按照以下所示的程序

(1)。(圖 8)

此外，當變更用作鋸片下限位置止動片的 8 mm 深度調節螺栓的位置時。

- (1) 轉動 8 mm 深度調節螺栓，變更螺栓頭與鉸鏈接觸處的高度，並調整鋸片的下限位置。

註

確認鋸片已調整，使其不會切入回轉台。

切割之前

1. 將導板定位 (圖 9)

導板安裝在回轉台。本工具從工廠出貨時，導板固定得非常牢固，鋸片並不會與其碰觸。如果導板被固定住，以致於導板側面和鋸片之間間隙達到最小，工件底部表面的毛邊顯著降低。使用本工具之前，按照以下程序消除此間隙。

(1) 直角切割

鬆開三個 5 mm 螺絲，然後固定左側導板並暫時旋緊兩端的 5 mm 螺絲。接著用虎鉗組件固定工件 (約 200 mm 寬)，並將其切割下來。將切割面對準導板邊緣之後，旋緊兩端的 5 mm 螺絲。取下工件並牢牢旋緊 5 mm 中心螺絲。以同樣的方式調整右手導板。

(2) 左側和右側斜角切割

以與直角切割相同的步驟調整導板。

注意

將導板調整為直角切割用之後，如果導板被用於斜角切割，會被切割到某種程度。

需要進行斜角切割操作時，請將導板調整為斜角切割用。

2. 確認副擋板 (A) 的使用 (圖 10)

警告

右斜角切割時，鬆開 6 mm 翼狀螺栓，然後向外滑動副擋板 (A) 並將其取下。否則可能會導致主體或鋸片與副擋板 (A) 接觸，從而引起傷害。

本電動工具配備有一個副擋板 (A)。對於直接角度切割和左側斜角切割，請使用副擋板 (A)。這樣您就可以穩定切割有寬大背面的材料了。

注意

對於直角切割和左側斜角切割，向內滑動至碰到副擋板 (A) 的位置，並用 6 mm 翼狀螺栓將其固定。(如圖 10 所示)

3. 確認副擋板 (B) 的使用 (圖 11)

警告

左斜角切割時，鬆開 6 mm 翼狀螺栓，然後向外滑動副擋板 (B)。否則可能會導致主體或鋸片與副擋板 (B) 接觸，從而引起傷害。

本電動工具配備有一個副擋板 (B)。對於直接角度切割和右側斜角切割，請使用副擋板 (B)。這樣您就可以穩定切割有寬大背面的材料了。

注意

對於直角切割和右側斜角切割，向內滑動至碰到副擋板 (B) 的位置，並用 6 mm 翼狀螺栓將其固定。(如圖 11 所示)

4. 滑動台架系統 (圖 12)

警告

為了降低受傷風險，請在每次橫切操作後將滑動台架完全返回後部位置。

對於小工件上的切割操作，請將切割頭組件完全滑向本機後部並鎖緊滑動固定旋鈕。若要切割寬度達 312 mm 的寬板，必須鬆開滑動固定旋鈕，使切割頭可以自由滑動。

5. 斜接尺調整

○ 降低機頭並插入鎖定銷。

解鎖斜接鎖定手柄並擺動回轉台，直到限位擋塊將其鎖定在 0° 斜接位置。

請勿鎖定斜接鎖定手柄。在切斷機的擋板和鋸片上放置一個方塊，如圖 13 所示。(請勿讓方塊接觸鋸齒的尖端。否則會導致測量不準確。)

如果鋸片不完全垂直於擋板，則鬆開固定斜切尺的 6 mm 螺絲 (4 顆)，並且左右移動斜切鎖定手柄和尺，直到鋸片垂直於擋板，正如用方塊所測量。

重新旋緊 6 mm 螺絲 (4 顆)。(圖 13)

此時無須注意指針的讀數 (用於斜切尺)。

○ 指針 (用於斜接尺) 調整

解鎖斜接鎖定手柄，將回轉台移動至 0° 位置。在斜接鎖定手柄解鎖的狀態下，當您將回轉台旋轉至 0° 時，讓限位擋塊卡入到位。

觀察指針 (用於斜接尺) 和斜接尺，如圖 13 所示。如果指針 (用於斜接尺) 未準確指示 0°，則鬆開固定指針 (用於斜接尺) 的 4 mm 螺絲。就地重新定位指針 (用於斜接尺) 並旋緊 4 mm 螺絲。

6. 斜接角調整

多角度切斷機刻度可輕易讀取，顯示左右 0° 至 45° 的斜接角度。切斷機工作台有九種最常見的角度設定，在 0°、15°、22.5°、31.6° 和 45° 處有限位擋塊。這些限位擋塊快速且準確地將刀片定位在所需的角度的。請按照以下程序進行最快速、最準確的調整。(圖 14)

中國語

調整斜接角度：

- (1) 向上推斜接鎖定手柄以鬆開回轉台。
- (2) 向下推限位擋塊桿直到止動桿卡在其上以釋放「限位擋塊」。
- (3) 旋轉回轉台並將指針設定為與斜接尺的所需角度對齊。此時，使用限位擋塊功能時，如圖 14 所示，沿箭頭方向拉動止動桿到所需的角度附近，鬆開止動桿，並透過限位擋塊功能移動回轉台使其固定到位在所需的角度。(0°、15°、22.5°、31.6° 和 45°)
- (4) 向下推斜接鎖定手柄以將回轉台固定到位。止動桿(圖 14)

止動桿可使工作台進行微調，解除限位止動擋塊功能。當所需的斜接角度接近限位止動擋塊時，該止動桿可防止限位擋塊桿上的楔塊滑入底座上的止動槽。

7. LED 照明系統(圖 15) [XACT CUT LED™]

注意

請勿凝視LED燈。直視光束可能會導致嚴重傷害或視力喪失。

LED 照明系統 [XACT CUT LED™] 可將鋸片的影子投射到工件上。其結果可提高切割的準確性，並且無需調整。

若要使用此功能，請打開 LED 燈開關。

將馬達頭朝下，使鋸片距離工件大約 6 mm。鋸片的影子將投射到工件上，當進行切割時，會指示鋸片齒將接觸的位置。

實際應用

警告

- 為避免人員受傷，使用工具時切勿從臺上移走工件或把工件放在臺上。
- 使用工具時切勿使四肢進入警告標誌旁邊的線內。(見圖 16)否則可能發生危險。

注意

- 鋸片正在運轉時，移走或安裝工作臺是非常危險的。
- 切割時，清除回轉臺上的鋸屑。
- 若鋸屑堆積過多，切割材料中的鋸片將暴露。切勿用手或其他物體靠近暴露的鋸片。

1. 開關操作

按下扳機即可打開開關。鬆開扳機即可關閉開關。(圖 17)

釋放開關時，制動器會對鋸片的旋轉起作用，使鋸片停止。

2. 打開 LED 燈

按下 LED 燈開關可切換 LED 燈。

3. 使用虎鉗組件(標準配件)(圖 18)

警告

始終將工件牢牢夾住或鉗住以固定在擋板，否則工件可能會從工作台上被猛烈推出並造成人體傷害。

注意

始終確認馬達頭在降低進行切割時不會接觸虎鉗組件。如果有任何可能碰到的危險，將虎鉗組件移動到不會接觸到鋸片的位置。

- (1) 虎鉗組件可以安裝在底座上。
- (2) 轉動上部旋鈕，將工件牢牢地固定到位(圖 18)。

註

使用虎鉗時，確保當裝置在擺動或滑動時，工具不會過度接觸。

4. 切割操作

- (1) 如圖 19 所示，鋸片的寬度為切割寬度。因此，在需要長度 ⑥ 時將工件向右側滑動(從操作員的位置看去)，或在需要長度 ③ 時向左側滑動。
打開 LED 燈，將鋸片的影子投射到工件上，將鋸片影子的左側或右側對準工件上的墨線。
- (2) 打開開關並確認鋸片以最大速度旋轉之後，緩慢地壓下手柄，使鋸片接近要切割的材料。
- (3) 鋸片接觸工件後，逐漸壓下手柄，以切入工件。
- (4) 切入工件至所需的深度後，關閉電動工具，讓鋸片完全停止，再從工件中提起手柄，使其回到完全收回位置。

警告

- 不使用工具時，確認按鍵開關已關閉，且電源插頭從插座中拔出。
- 在從工件上抬起手柄之前，務必先切斷電源並讓鋸片完全停止轉動。如果鋸片仍在轉動時抬起手柄，則被切除的碎片可能會卡住鋸片，導致碎片撒開，非常危險。
- 每次完成深切割操作後，關閉開關，檢查鋸片是否停止。然後提起手柄，並使其回到完全收回位置。
- 請務必清除回轉臺上的切割材料，然後進行下一步。
- 連續的切割操作會導致馬達的過載。觸摸馬達，如果很燙，請停止切割操作一次並休息10分鐘左右，然後重新啟動切割操作。

注意

- 關於切割的最大尺寸，參見“規格”表。
 - 在手柄上加壓並不能提高切割速度。相反，壓力過大可能使電動機過載與/或降低切割效率。
5. 切割狹窄工件(按壓切割)(圖 20)
將鉸鏈向下滑動到支架(A)，然後旋緊滑動式固定旋鈕。降低手柄以切割工件。以這種方式使用電動工具時可切割達107 mm的正方形工件。

6. 切割大型工件(圖 21)

根據工件的高度，有可能無法進行完整的切割。在這種情況下，使用擋板表面上的7 mm孔（每側兩孔）以6 mm的平頭螺絲和6 mm的螺母安裝一個輔助板。有關輔助板的厚度，請參閱「規格」。

註

以直角切割方式切割高度超過107 mm的工件時，或以左側斜角切割高度超過70 mm的工件，或以右側斜角切割高度超過45 mm的工件時，調整下限位置使鋸頭的底座不會與工件接觸。

要調整鋸片的下限位置時，按照圖 22所示的程序

(1)。

- 降低鋸頭，轉動6 mm深度調節螺栓並進行調整，使鋸頭的下限位置和在鋸片下限位置的工件頂部之間有2 mm至3 mm的間隙，在這裡6 mm深度調節螺栓會接觸到鉸鏈。

7. 切割寬型工件(滑動切割)(圖 23)

- 高達107 mm，寬達312 mm的工件：鬆開滑動式固定旋鈕，握住手柄並向前滑動鋸片。然後將手柄向下按並滑回鋸片以切割工件。這有助於切割高度達107 mm和寬度達312 mm的工件。
- 高達120 mm，寬達260 mm的工件：高度達120 mm和寬度達260 mm的工件可以使用與上段6-(1)所述的相同方式進行切割。

警告

- 請按照程序進行滑動切割。向前滑動切割(朝向操作員)是非常危險的，因為鋸片可能會從工件向上反彈。因此，滑動手柄時務必遠離操作員。
- 為了降低受傷的風險，每次進行橫切操作之後，務必將滑動臺架恢復到最後面的位置。
- 當馬達頭降低時，鋸片會往斜接鎖定手柄靠近，因此在切割操作過程中，切勿將您的手放在斜接鎖定手柄上。

注意

- 切割120 mm高度的工件時，調整鋸頭的下限位置，使鋸頭的下部邊緣與工件之間的間隙在下限位置為2至3 mm。
- 如果以過度或橫向的力量按下手柄，鋸片可能會在切割操作期間產生振動，並導致工件上留下不需要的切割痕跡，從而降低切割品質。因此，請輕輕地小心地按下手柄。
- 進行滑動切割時，請一次就平順地輕輕將手柄推回(向後)。切割過程中停止手柄的移動將導致工件上留下不需要的切割痕跡。

8. 斜角切割步驟(圖 24)

警告

變更傾斜角度時，按住馬達頭。如果馬達頭突然移動到傾斜角度，可能會導致受傷或主機體損壞。

- 鬆開斜角鎖定手柄，使鋸片向左或向右成斜角。若要將斜角角度變更為右側，請鬆開斜角鎖定手柄，然後向前拉出定位銷(A)，並將馬達頭向右傾斜。當馬達頭直豎時，定位銷(A)被牢固地固定到位，因此在拉出定位銷(A)時，請先將馬達頭稍微向左傾斜，然後再將馬達頭向右傾斜。
- 看著斜角尺和指針將斜角調整為所需的設定，然後固定斜角鎖定手柄。

警告

- 務必檢查斜角鎖定手柄是否牢固，以及馬達頭是否已夾緊。如果在馬達頭未夾緊的狀態下嘗試進行角度切割，則馬達頭可能會意外移動而導致受傷。
- 工件固定於鋸片左側或右側時，短小的切除部分會相應停留在鋸片右側或左側。在從工件上抬起手柄之前，務必先切斷電源並讓鋸片完全停止轉動。
- 如果鋸片仍在轉動時抬起手柄，則被切除的碎片可能會卡住鋸片，導致碎片撒開，非常危險。中途停止斜角切割作業時，應將電動頭拉回初始位置，再開始切割。
- 如未拉回而從中途開始切割，則會造成下部安全罩卡在工件的切割凹槽中，並接觸到鋸片。
- 右角切割時，鬆開6 mm翼狀螺栓，然後向外滑動副擋板(A)並將其取下。
- 左角切割時，鬆開6 mm翼狀螺栓，然後向外滑動副擋板(B)。

注意

以左側45°斜角切割位置切割75 mm高度的工件時，或是以右側45°斜角切割位置切割50 mm高度的工件時，調整鋸頭的下限位置，使鋸頭的下部邊緣與工件之間的間隙在下限位置為2至3 mm(參閱第30頁的「11. 檢查鋸片下限位置」)。

註

斜角鎖定手柄採用離合器系統。當斜角鎖定手柄與主機體接觸時，按圖 24所示的箭頭標記方向拉動斜角鎖定手柄，並改變斜角鎖定手柄的方向。

9. 斜接切割步驟(圖 25)

- 抬起斜接鎖定手柄，解鎖斜接工作台。
- 輕輕按下限位擋塊桿直至其與止動桿接合，同時抓住斜接鎖定手柄並向左或向右旋轉工作台至所需的角度的。
- 一旦達到所需的斜接角度，將斜接鎖定手柄向下按以將工作台固定到位。
- 如果所需的斜接角度是下述的九個限位擋塊之一，請參見圖 14上的斜接止動桿部分。
- 打開LED燈並將工件放在工作台上，以便預先對齊要進行的切割作業。

中國語

注意

務必檢查斜接鎖定手柄是否牢固，以及回轉台是否已夾緊。
如果在回轉台未夾緊的狀態下嘗試進行角度切割，則回轉台可能會意外移動而導致受傷。

註

- 在 0° 中心設定的右側和左側、15°、22.5°、31.6° 和 45° 設定處均設有有限擋塊。檢查斜接尺和指針的尖端是否正確對齊。
- 斜接尺和指針未對齊的狀態下操作鋸機將導致切割精度差。

10. 複合切割步驟

您可以按照上述 8 和 9 中的說明進行複合切割。關於複合切割的最大尺寸，請參閱「規格」表。

注意

始終以右手或左手來固定工件，並用右手或左手向後滑動鋸機的圓形部分來進行切割。
在複合切割過程中將回轉台向右或向左旋轉是非常危險的，因為鋸片可能會接觸到正在固定工件的手。

如果是以左斜角進行複合切割(角度+斜角)，請向外滑動副擋板(B)，並進行切割操作。

如果是以右斜角進行複合切割(角度+斜角)，請移除副擋板(A)，並進行切割操作。

11. 切割長型材料

切割長型材料時，使用與支架(選購件)和特殊輔助設備的底座相同高度的輔助平台。

能力:

木材(W × H × L)

300 mm × 45 mm × 1300 mm, 或

180 mm × 25 mm × 2000 mm

12. 安裝支架 … (選購件)

在切割操作中，支架可用于延長工件台並使之保持正確位置。

- (1) 如圖 26 所示，使用方鋼來對齊支架的上緣與底座面。鬆開 6 mm 翼狀螺母。旋轉高度調節螺栓，並調節支架的高度。鬆開 6 mm 翼狀螺母。旋轉高度調節螺栓，並調節支架的高度。
- (2) 調節後，旋緊 6 mm 的翼狀螺母並用 6 mm 旋鈕螺栓(選購件)固定支架。如高度調節螺栓 6 mm 的長度不足，則在其下方放置一塊薄板。高度調節螺栓 6 mm 的末端不得從支架中突出。

注意

在搬運此電動工具時，請勿抓住其支架。支架有滑出底座的危險。應抓住手柄而不要抓住支架。

13. 精密切割的止動片 … (止動片與支架為選購件)

止動片有助於長度為 285 mm 至 450 mm 的連續精密切割。安裝止動片時，按照圖 27 所示，用 6 mm 翼栓將其與支架連接。

14. 確認使用冠狀模塑虎鉗、冠狀模塑止動片(L)和冠狀模塑止動片(R) (選購件)

- (1) 通過冠狀模塑止動片(L)與(R) (選購件)，可以方便地切割冠狀模塑，而無需傾斜鋸片。將其安裝在底座兩側，如圖 28 所示。插入後旋緊 6 mm 旋鈕螺栓，以固定冠狀模塑止動片。
- (2) 冠狀模塑虎鉗(B) (選購件)可安裝在左擋板(擋板(B))或右擋板(擋板(A))上。它可與冠狀模塑的斜角結合，並可按下虎鉗。然後按照需要轉動上部旋鈕，以可靠地連接冠狀模塑。要升高或降低虎鉗組件，首先鬆開六角套筒固定螺絲。調節高度後，旋緊 6 mm 翼栓，然後按照需要旋轉上部旋鈕，以可靠地連接冠狀模塑(圖 29)。放置冠狀模塑時，使其壁接觸緣貼緊導引擋板，而其頂接觸緣貼緊冠狀模塑止動片，如圖 29 所示。根據冠狀模塑的大小來調節冠狀模塑止動片。旋緊 6 mm 翼栓以固定冠狀模塑止動片。有關斜接角，請參閱下表。使用副擋板(A)更加緊固冠狀模塑。

警告

務必夾緊或用虎鉗將冠狀模塑固定在擋板上，否則冠狀模塑可能從臺上沖出，而造成人身傷害。不要進行斜角切割。主體或鋸片可能與副擋板接觸，從而引起傷害。

注意

務必確認鋸頭在降低進行切割時不會接觸冠狀模塑虎鉗組件。

如果有任何可能碰到的危險，鬆開六角套筒固定螺絲，並將冠狀模塑虎鉗組件移動到不會接觸到鋸片的位置。

15. 凹槽切割步驟

可透過調整 6 mm 深度調節螺栓來進行工件凹槽的切割(圖 30)。

- (1) 降低鋸頭，並用手轉動 6 mm 深度調節螺栓。(此時 6 mm 深度調節螺栓的頭部接觸到鉸鏈。)
- (2) 透過設定鋸片和底座表面之間的距離，調整到所需的切割深度(圖 30)。

註

在工件的任何一端切割單凹槽時，用鑿子移除不需要的部分。

16. 連接集塵器(另售)(圖 31)

切勿吸入切割作業過程中產生的有害粉塵。

粉塵會危及您和旁觀者的健康。

使用集塵器能減少與粉塵有關之危害。

將適配器、接頭和集塵適配器與集塵器連接，可收集大部分的灰塵。

連接集塵器與適配器。

- (1) 依照軟管(內徑 38 mm × 3 m 長)、適配器(集塵器的標準附件)、接頭(選購件)、集塵適配器(選購件)的順序，與電動工具的導管連

接。依箭頭方向按壓即完成連接。(圖 31)
集塵適配器(選購件)透過軟管帶固定到導管。
(選購件)

副組件可能會在搬運過程中掉落。拆下組件或在虎鉗之間塞入一塊木板以牢牢將其固定。(圖 33-b)

降低機頭並插入鎖定銷(參見第 30 頁「7.釋放鎖定銷」)。還要鎖入滑動式固定旋鈕,使鉸鏈定位到可以碰到支架(A)並固定頭部。(圖 33-a)

提起斜接鎖定手柄,將回轉台盡可能向右轉動,然後將斜接鎖定手柄向下壓至固定位置以固定回轉台。這將使主機體更加小巧。(圖 33-b)

搬運主機體時,將其抱在懷裡,雙手握住位於底座上的握把。

兩人搬運時,每人應用雙手握住提手、手柄和底座握把。

維護和檢查

警告

為防止發生事故或人身傷害,在進行任何檢查或維護之前,請務必關閉觸發開關並從插座上拔下電源插頭或取出電池。

1. 檢查鋸片

發現變質或損壞後應立即更換鋸片。損壞的鋸片可引起人身傷害,而磨損的鋸片則可導致無效的操作,並可能使馬達過載。

注意

切勿使用不鋒利的鋸片。鋸片不鋒利時,它對於由工具手柄所施加的手部壓力的阻力會增加,使電動工具的使用變得不安全。

2. 檢查安裝螺釘

要經常檢查安裝螺釘是否緊固妥善。若發現螺釘鬆了,應立即重新扭緊,否則會導致嚴重的事務。

3. 檢查碳刷(圖 35)

本工具的馬達上使用了碳刷,碳刷為消耗性零件。若使用過度磨損的碳刷,便會引起馬達故障。因此,當碳刷已損壞或接近“磨損極限”時,請用新碳刷更換之。新碳刷的號碼必須與圖示號碼相同。另外,請保持碳刷潔淨,並請確認碳刷在碳刷座內是否能自由滑動。

4. 更換碳刷(圖 35)

請使用一字頭螺絲起子拆解刷蓋。彈簧可使碳刷容易取下。

5. 馬達的維護

馬達繞線是電動工具的心臟部。應仔細檢查有無損傷,是否被油液或水沾濕。

6. 檢查下部安全罩是否正常運作

○在每次使用工具之前,測試下部安全罩(圖 34)以確保其處於良好狀態並且移動流暢。

鋸片的安裝及拆卸

警告

為防止發生事故或人身傷害,在拆卸或安裝鋸片之前,請務必關閉按鍵開關並從插座上拔下電源插頭。

1. 安裝鋸片(圖 32)

(1)壓入主軸鎖並用 8 mm 六角棒狀扳手(標準配件)鬆開 10 mm 螺栓。

由於 10 mm 螺栓為左旋螺紋,需向右旋轉將其鬆開。

註

○如果主軸鎖無法輕易壓入以鎖定主軸,則用 8 mm 六角棒狀扳手(標準配件)轉動 10 mm 螺栓,同時對主軸鎖施加壓力。

○向內按壓主軸鎖時,鋸片主軸被鎖定。

(2)取下螺栓和墊圈(B)

(3)提起下部安全罩並安裝鋸片。

警告

安裝鋸片時,確認鋸片上的旋轉指標標誌與齒輪箱的旋轉方向(圖 1)完全一致。

(4)仔細清洗墊圈(B)與 10 mm 螺栓,並將其安裝在鋸片主軸上。

(5)按入主軸鎖,並用 8 mm 六角棒狀扳手(標準配件)向左轉緊 10 mm 螺栓。

警告

旋緊 10 mm 螺栓,使其不會在操作過程中鬆動。在啟動本電動工具之前,請確認 10 mm 螺栓已完全旋緊。

注意

○集塵引導器安裝在鉸鏈後面內部。拆卸或安裝鋸片時,不要碰觸到集塵引導器。否則可能會損壞或在鋸片尖端造成缺口。(圖 32)

○安裝或拆卸鋸片後,確認主軸鎖已返回到縮回位置。

2. 拆下鋸片

按照相反的安裝步驟拆卸鋸片。

提起下部安全罩後可輕易拆下鋸片。

注意

切勿嘗試安裝直徑 305 mm 以外的鋸片。

主機體的搬運

警告

為避免事故或人體傷害的發生,在搬運主機體之前,務必確認按鍵開關已關閉並且取出電池。

中國語

○ 除非下部安全罩正常運作且機械狀況良好，否則切勿使用本工具。

7. 潤滑

每月應潤滑以下滑動面一次，以使電動工具長時間保持良好的工作狀態。

請使用推薦的機油。

注油位置：

- 回轉支架的轉動部分
- 支架(A)的轉動部分
- 虎鉗組件的轉動部分

8. 清潔

用空氣槍或其他工具吹出乾空氣來清潔機器、導管和下部安全罩。(圖 36)

定期地用沾有肥皂水的濕布除去電動工具表面上的碎屑和其他廢料。為了避免馬達故障，切勿使其接觸油或水。

如果 LED 發光部分的窗口上粘有鋸屑等而導致 LED 線看不見，請用乾布或沾有肥皂水的軟布等擦拭並清潔窗口。

9. 收藏

工具操作完成後，檢查是否執行了以下事項：

- (1) 按鍵開關處於關閉位置，
 - (2) 電源插頭已從插座拔下，
- 不使用工具時，請將其存放在兒童接觸不到的乾燥處。

選擇配件

本機器的附件列在第38頁。

注意

HiKOKI電動工具的修理、修改和檢查必須由HiKOKI授權服務中心進行。

在操作和維修電動工具中，必須遵守各國的安全規則和標準規定。

註

為求改進，本手冊所載規格可能不預先通告而徑予更改。

故障排除

若電動工具無法正常運作，請參閱下表的檢查項目。若問題仍無法解決，請洽當地經銷商或HiKOKI所認可的維修中心。

情況	可能原因	解決方法
工具突然停止	工具負載過重	除去造成工具負載過重的問題
	馬達為防止工具故障而自動停止	這不是故障 扳機關關已被按住5分鐘以上 再次打開電源
不能傾斜	斜角鎖定手柄沒有鬆開	鬆開斜角鎖定手柄，然後傾斜本工具 調整鬆動的組件後，務必再次旋緊
不能向右傾斜	定位銷(A)沒有拉出	拉出定位銷(A)後向右傾斜
	斜角鎖定手柄沒有鬆開	鬆開斜角鎖定手柄，然後傾斜
鋸片變鈍	鋸片磨損或缺少鋸齒	更換新鋸片
	螺栓鬆動	鎖緊螺栓
	鋸片反向安裝	以正確的方向安裝鋸片
不能準確切割	工具的操作零件未完全固定	完整安裝斜角鎖定手柄和斜接鎖定手柄
	材料無法固定在正確的位置	從擋板或回轉台上移除任何異物

情況	可能原因	解決方法
不能準確切割	材料無法固定在正確的位置	在某些情況下，由於材料中的曲線，無法固定正確的位置。嘗試用擋板或回轉台固定平面

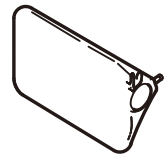
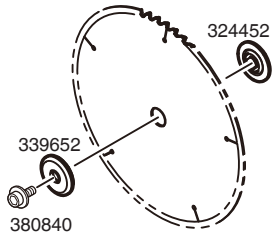

322955



955857

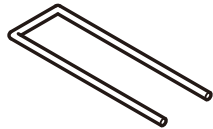

376730

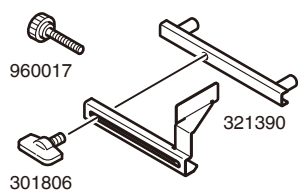

339730

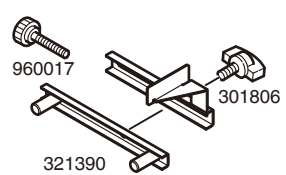

339731

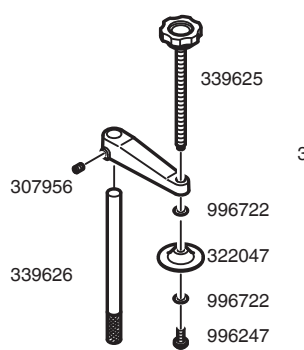

339624

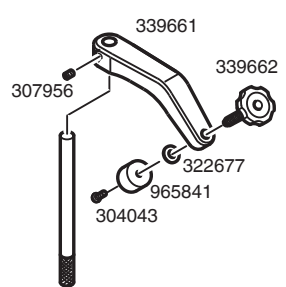

339660

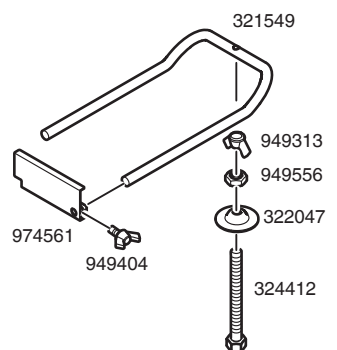

324464

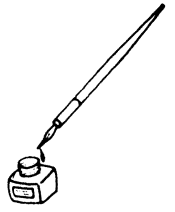

Koki Holdings Co., Ltd.

508
Code No. C99748232
Printed in China