

HiKOKI

充电式锤钻

Cordless Rotary Hammer

DH 1826DA · DH 1826DC

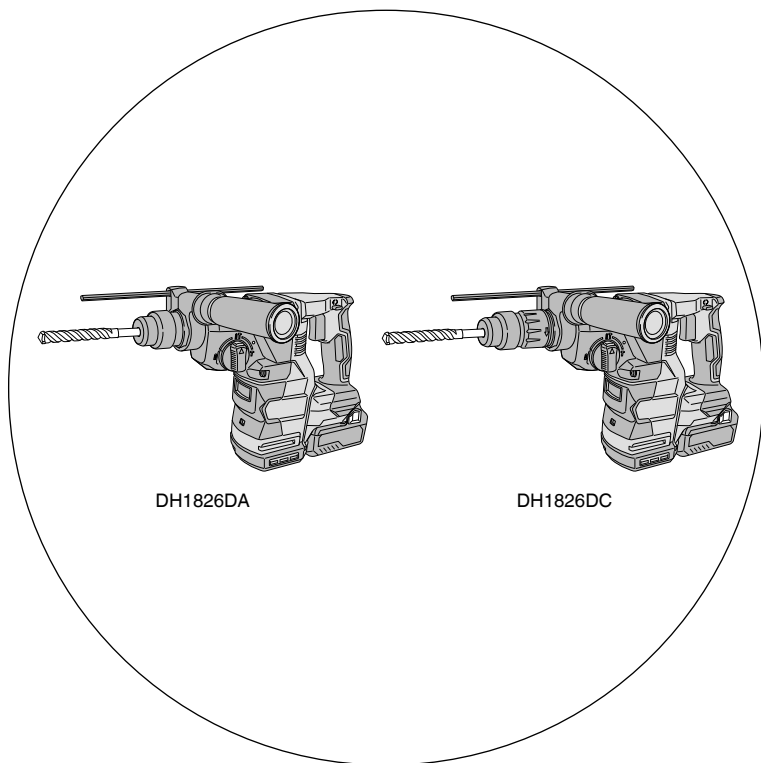

DH1826DA

DH1826DC

保留备用

Keep for future reference



使用说明书

Handling instructions

目次

电动工具通用安全警告.....	2	作业之前.....	15
充电式锤钻安全警告.....	5	使用方法.....	19
其它安全警告.....	5	怎么样使用取心钻具（轻载用）.....	23
锂离子电池使用注意事项.....	7	操作上的注意事项.....	24
锂离子电池运输.....	8	选择操作模式.....	25
符号.....	9	自停功能.....	25
规格.....	9	反作用力控制.....	26
标准附件.....	10	关于保护功能.....	27
用途.....	10	润滑.....	27
电池的拆卸 / 安装法.....	11	维护和检查.....	28
充电.....	12	故障排除.....	30
USB 设备的充电方法.....	14	选择附件.....	33

电动工具通用安全警告

⚠ 警告！

阅读电动工具附带的所有安全警告、说明、插图和规格说明。
不遵照以下说明会导致电击、着火和 / 或严重伤害。

保存所有警告和说明书以备查阅。

在所有下列的警告中术语“电动工具”指市电驱动（有线）电动工具或电池驱动（无线）电动工具。

1) 工作场地的安全

- a) 保持工作场地清洁和明亮。
混乱和黑暗的场地会引发事故。
- b) 不要在易爆环境，如有易燃液体、气体或粉尘的环境下操作电动工具。
电动工具产生的火花会点燃粉尘或气体。
- c) 让儿童和旁观者离开后操作电动工具。
注意力不集中会使操作者失去对工具的控制。

2) 电气安全

- a) 电动工具插头必须与插座相配。绝不能以任何方式改装插头。
需接地的电动工具不能使用任何转换插头。
未经改装的插头和相配的插座将减少电击危险。
- b) 避免人体接触接地表面，如管道、散热片和冰箱。
如果你身体接地会增加电击危险。
- c) 不得将电动工具暴露在雨中或潮湿环境中。
水进入电动工具将增加电击危险。

- d) 不得滥用电线。绝不能用电线搬运、拉动电动工具或拔出其插头。使电线远离热源、油、锐边或运动部件。
受损或缠绕的软线会增加电击危险。
- e) 当在户外使用电动工具时，使用适合户外使用的外接软线。
适合户外使用的软线将减少电击危险。
- f) 如果在潮湿环境下操作电动工具是不可避免的，应使用剩余电流动作保护器（RCD）。
使用RCD可减小电击危险。

3) 人身安全

- a) 保持警觉，当操作电动工具时关注所从事的操作并保持清醒。
当你感到疲倦，或在有药物、酒精或治疗反应时，不要操作电动工具。
在操作电动工具时瞬间的疏忽会导致严重人身伤害。
- b) 使用个人防护装置。始终佩戴护目镜。
安全装置，诸如适当条件下使用防尘面具、防滑安全鞋、安全帽、听力防护等装置能减少人身伤害。
- c) 防止意外起动。确保开关在连接电源和 / 或电池盒、拿起或搬运工具时处于关断位置。
手指放在已接通电源的开关上或开关处于接通时插入插头可能会导致危险。
- d) 在电动工具接通之前，拿掉所有调节钥匙或扳手。
遗留在电动工具旋转零件上的扳手或钥匙会导致人身伤害。
- e) 手不要伸展得太长。时刻注意立足点和身体平衡。
这样在意外情况下能很好地控制电动工具。
- f) 着装适当。不要穿宽松衣服或佩戴饰品。让衣服、手套和头发远离运动部件。
宽松衣服、佩饰或长发可能会卷入运动部件中。
- g) 如果提供了与排屑、集尘设备连接用的装置，要确保它们连接完好且使用得当。
使用这些装置可减少尘屑引起的危险。
- h) 请勿因频繁使用工具的熟悉感而掉以轻心，忽视工具的安全性原则。
粗心的行为可能会导致瞬间发生严重伤害。

4) 电动工具使用和注意事项

- a) 不要滥用电动工具，根据用途使用适当的电动工具。
选用适当设计的电动工具会使你工作更有效、更安全。
- b) 如果开关不能接通或关断工具电源，则不能使用该电动工具。
不能用开关来控制的电动工具是危险的且必须进行修理。
- c) 在进行任何调整、更换附件或存放电动工具之前，必须从电源上拔掉插头和 / 或取下电池盒（如果可拆卸）。
这种防护性措施将减少工具意外起动的危险。

- d) 将闲置不用的电动工具贮存在儿童所及范围之外，并且不要让不熟悉电动工具或对这些说明不了解的人操作电动工具。
电动工具在未经培训的用户手中是危险的。
- e) 维护电动工具和附件。检查运动件是否调整到位或卡住，检查零件破损情况和影响电动工具运行的其他状况。如有损坏，电动工具应在使用前修理好。
许多事故由维护不良的电动工具引发。
- f) 保持切削刀具锋利和清洁。
保养良好的有锋利切削刃的刀具不易卡住而且容易控制。
- g) 按照使用说明书，考虑作业条件和进行的作业来使用电动工具、附件和工具的刀头等。
将电动工具用于那些与其用途不符的操作可能会导致危险。
- h) 保持手柄和抓握表面干燥、清洁，远离油和油脂。
如果手柄和抓握表面湿滑，可能导致在发生意外情况时，无法安全操作和控制工具。

5) 电池式工具使用和注意事项

- a) 只用制造商规定的充电器充电。
将适用于某种电池盒的充电器用到其他电池盒时会发生着火危险。
- b) 只使用配有特制电池盒的电动工具。
使用其他电池盒会发生损坏和着火危险。
- c) 当电池盒不用时，将它远离其他金属物体，例如回形针、硬币、钥匙、钉子、螺钉或其他小金属物体，以防一端与另一端连接。
电池端部短路会引起燃烧或火灾。
- d) 在滥用条件下，液体会从电池中溅出；避免接触。如果无意间碰到了，用水冲洗。如果液体碰到了眼睛，还要寻求医疗帮助。
从电池中溅出的液体会发生腐蚀或燃烧。
- e) 请勿使用损坏或改装的电池盒或工具。
损坏或改装的电池可能会引发突发状况，导致火灾、爆炸或受伤。
- f) 请勿将电池盒或工具暴露在有火源或高温环境中。
如果暴露在有火源或 130 度以上高温的环境中，可能引起爆炸。
- g) 请完全按照充电说明进行操作，不要在说明中规定的温度范围外的环境中对电池盒或工具充电。
充电不当或在规定温度范围外的环境中充电可能会导致电池损坏，增加发生火灾的风险。

6) 维修

- a) 将你的电动工具送交专业维修人员，使用同样的备件进行修理。
这样将确保所维修的电动工具的安全性。
- b) 请勿维修已损坏的电池盒。
需由制造商或经授权的服务供应商进行维修。

注意！

不可让儿童和体弱人士靠近工作场所。

应将不使用的工具存放在儿童和体弱人士接触不到的地方。

充电式锤钻安全警告

1. 戴好耳罩。
暴露在噪声中会引起听力损伤。
2. 如果随工具提供辅助手柄，请使用。
操作失手会引起人身伤害。
3. 在操作过程中，切削附件可能会触碰到隐藏的线缆，因此请握住电动工具的绝缘夹持面。切削附件碰到带电导线会使工具外露的金属零件带电从而使操作者受到电击。

使用带锤钻的长钻头时的安全说明

4. 务必以低速开始钻孔，并将始终将钻头尖端接触工件。
在更高的速度下，如果钻头不接触工件而自由旋转，则其可能会弯曲，从而导致人身伤害。
5. 仅使用钻头以直线施加压力，并且请勿施加过大压力。
钻头可能会弯曲，导致破损或失控，从而造成人身伤害。

其它安全警告

1. 勿让杂质进入可充电电池的连接口内。
2. 切勿拆卸充电式电池与充电器。
3. 切勿使可充电电池短路。电池短路会引起强电流和过热。从而烧坏电池。
4. 请勿将电池丢入火中。电池受热将会爆炸。
5. 长时间连续使用本电钻，可能会导致机体过热，对马达及开关造成损害，因此使用本机请勿连续超过 15 分钟。
6. 请勿将异物插入充电器的通风口。将金属物体或易燃物插入充电器的通风口会导致触电事故或损坏充电器。
7. 充电后的电池寿命太短不够使用时，请尽快将本电池送往购买时的经销店。请勿将用过的电池乱丢。
8. 对墙壁、天花板和地板进行钻孔或钻碎作业时，应彻底查明里面是否敷设电缆或导管。
9. 确认电源开关已切断。若电源开关接通，则安装电池后，电动工具将出其不意地立刻转动，从而导致严重事故。
10. 作业之后的钻头仍处在此高热状态下，切不可摸触，以免灼伤。
11. 使用锤钻时，应牢牢握住工具的操作柄和侧柄。否则，所产生的反作用力会将孔钻歪，甚至会造成危险。

12. 佩戴防尘口罩

不要吸入在钻凿操作过程中产生的有害粉尘。粉尘会危及到自身和旁观者的身体健康。

13. 确保电池已牢固安装到位。如果电池松动，则会脱落出来，导致意外。

14. 为避免意外事故，请务必关闭开关，并在更换附件、存储、搬运前或不使用工具时取出电池。

15. 安装钻头

○ 为避免意外事故，请务必关闭开关并取出电池。

○ 当使用尖钻、钻头工具时，请务必使用本公司原装配件。

○ 清洁钻头的柄部分。

○ 拉拽钻头以检查是否完全插紧。

16. 仅在电机完全停止时操作选择杆。如果在电机运行时操作选择杆，可能会导致钻头工具出其不意地旋转，从而导致事故。（第20页的图 21）

17. 旋转 + 锤钻

DH1826DC：使用钻头夹（标准配件）

钻头碰到建筑物的钢筋时会立即停止转动，电动锤钻将随即转动。因此，请旋紧侧柄，并握住操作柄和侧柄。

18. 只旋转

DH1826DC：使用钻夹头刀柄（标准配件）

○ 利用选购的钻头夹盘及夹盘附加器（选购件）于木材或金属质材上钻孔。

○ 请勿使用除尘器系统。

○ 操作时请勿过分用力。否则不仅会损坏钻头的刃尖，还会缩短锤钻的使用寿命。

○ 钻头在钻孔时可能会折断。当钻头即将穿透时，减轻锤钻上的压力并继续钻孔，直至穿透为止。

○ 不要在单旋钻的功能下用锤钻钻锚孔或在混凝土上钻孔。

○ 装有钻头夹盘和夹盘附加器时，不要在旋钻和锤击模式下使用电动锤钻。这会严重缩短机器各个部件的寿命。

19. 只锤钻

DH1826DC：使用钻头夹（标准配件）

○ 请勿使用除尘器系统。

20. 请勿直视光源。这些行为可能会导致眼睛不适。

用软布仔细擦拭附着在 LED 灯镜片上的灰尘或污垢，小心不要划伤镜片。

如果划伤 LED 灯的镜片，可能会导致亮度减弱。

21. 在操作期间请务必如图 1 所示牢牢握住工具。



图 1

锂离子电池使用注意事项

为延长使用期限，锂离子电池备配停止输出的保护功能。

若是在使用本产品时发生下列 1 至 3 的情况，即使按下开关，马达也可能停止。这并非故障，而是启动保护功能的结果。

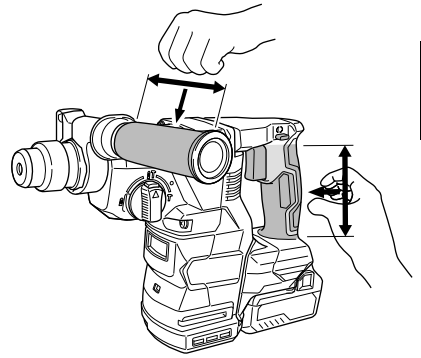
1. 在残留的电池电力即将耗尽时，马达会停止。
在这种情况下，请立即予以充电。
2. 若工具超过负荷，马达亦可能停止。在这种情况下，请松开工具的开关，试着消除超过负荷的原因。之后您就可以再度使用。
3. 若电池在过载工作情况下过热，电池电力可能会中止。
在这种情况下，请停止使用电池，让电池冷却。之后您就可以再度使用。

此外，请留心下列的警告及注意事项。

警告！

为防止发生电池漏电、发热、冒烟、爆炸及提前点燃，请确保留意下列事项。

1. 确保电池上没有堆积削屑及灰尘。
 - 在工作时确定削屑及灰尘没有掉落在电池上。
 - 确定所有工作时掉落在电动工具上的削屑和灰尘没有堆积在电池上。
 - 请勿将未使用的电池存放在曝露于削屑和灰尘的位置。
 - 在存放电池之前，请清除任何可能附着在上面的削屑和灰尘，并请切勿将它与金属零件（螺丝、钉子等）存放在一起。
2. 请勿以钉子等利器刺穿电池、以铁锤敲打、踩踏、丢掷电池，或将其剧烈撞击。
3. 切勿使用明显损坏或变形的电池。
4. 使用电池时请勿颠倒电极。
5. 请勿直接连接电源插座或汽车点烟器孔座。
6. 请依规定方式使用电池，切勿移作他用。
7. 如果已过了再充电时间，电池仍无法完成充电，请立即停止继续再充电。
8. 请勿将电池放置于高温或高压处，例如微波炉、烘干机或高压容器内。

中文

9. 在发觉有渗漏或异味时，请勿接近远离火源。
10. 请勿在会产生强烈静电的地方使用。
11. 如有电池渗漏、异味、发热、褪色或变形，或在使用、充电或存放时出现任何异常，请立即将它从装备或电池充电器拆下，并停止使用。
12. 请勿浸泡电池或让任何液体流入电池内部。导电液体进入（如水），可能造成电池损坏，甚至可导致火灾或爆炸。将电池存放在阴凉、干燥的地方，远离易燃物品。必须避免将电池置于腐蚀性气体环境中。

注意！

1. 若电池渗漏出的液体进入您的眼睛，请勿搓揉眼睛，并以自来水等干净清水充分冲洗，立刻送医。
若不加以处理，液体可能会导致眼睛不适。
2. 若液体渗漏至您的皮肤或衣物，请立即以自来水等清水冲洗。
上述情况可能会使皮肤受到刺激。
3. 若初次使用电池时发现生锈、异味、过热、褪色、变形及 / 或其它异常情况时，请勿使用并将该电池退还给供货商或厂商。

警告！

如果有导电异物进入锂电池，可能发生短路，并有可能发生火灾危险的可能。请在贮存电池时，遵守如下事项。

- 请不要在电池盒内放置导电物体，如钉子、钢丝、铜丝或其他电线。
- 或者将电池装在电动工具中，或者在牢固按入电池盖并挡住通风孔后再存放，以防止短路（参照图 2）。



图 2

锂离子电池运输

当运输一个锂离子电池，请注意以下预防措施。

警告！

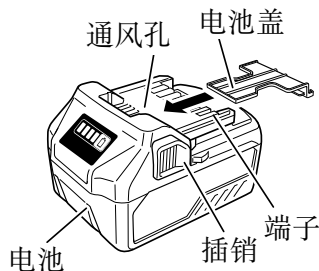
告知运输公司，包装内包含一个锂离子电池，告知该公司其功率输出并且要按照运输公司的指引安排运输。

- 功率输出超过 100 Wh 的锂离子电池被视作危险物品运输分类并且需要特别申请程序。
- 对于境外运输，您必须遵守国际法以及输入国的规章和条例。





图 3

符号

警告！

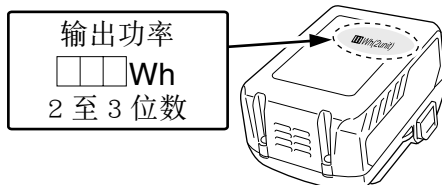
如下所示的符号用于本机。使用前请务必理解其含意。

	DH1826DA / DH1826DC: 充电式锤钻
	为降低伤害风险，用户必须阅读使用说明书

规格

电动工具

型式	DH1826DA	DH1826DC	DH1826DA*1	DH1826DC*1
电压	18V			
无负荷速度	0-950/min			
满载锤击率	0-4300/min			
能力	混凝土	26mm	20mm	
	金属	13mm	—	
	木材	27mm	—	
电池 *2	型号	BSL36A18		
	类型	锂离子电池（10 节）		
	电压	DC 36V / 18V（自动转换 *3）		
	电量	2.5Ah / 5.0Ah（自动转换 *3）		
重量（含 BSL36A18）	3.8kg	4.0kg	4.8kg	5.0kg

*1 带除尘器系统

*2 本工具不适用以下电池（BSL3660/3626X/3626/3625/3620 和 BSL14xx 系列）。

*3 工具自身可自动切换。

充电器

型式	UC18YSL3
充电电压	14.4-18V
重量	0.6kg

标准附件

除了主机（1 台）外，产品包中还包括表中所列的附件。

表 1

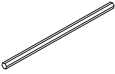
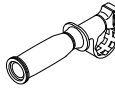
	DH1826DA		DH1826DC	
	(NNPS)	(NNP)	(NNPS)	(NNP)
除尘器系统 ●关于操作说明，请参阅 除尘器系统 使用说明书。	1	—	1	—
 深度计	1	1	1	1
 侧把手	1	1	1	1
 外壳 [No.2]	2 (主机 / 其他) (除尘器系统)	1	2 (主机 / 其他) (除尘器系统)	1
 钻头夹	—	—	1	1
 钻夹头刀柄	—	—	1	1

用途

旋钻与锤钻

- 钻开锚栓孔
- 对混凝土钻孔
- 对瓷砖钻孔

单纯旋钻（无排屑装置）

- 对钢材或木材钻孔
（与选购附件匹配使用）
- 旋紧机械螺丝、木螺丝
（与选购附件匹配使用）

单纯锤钻（无排屑装置）

- 轻凿混凝土、开槽和修边。

电池的拆卸 / 安装法

1. 电池的拆卸法

请先紧抓住把手，然后再推压电池插销以拆下电池（参照图 4 和图 5）。

注意！

切勿使电池短路。

2. 电池的安装法

插入电池时请注意极性（参照图 5）



图 4



图 5

(2) 可充电电池温度和充电时间相关资料。
温度和充电时间如表 3 所示。

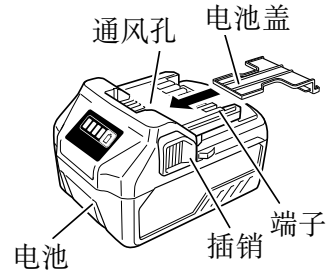
表 3

充电器		UC18YSL3					
电池	电池类型	锂离子电池					
	电池可充电温度	0°C – 50°C					
	充电电压	v	14.4		18		
	充电时间 (环境温度 20°C)	分钟	BSL14xx 系列		BSL18xx 系列		多电压系列
			(4 节)	(8 节)	(5 节)	(10 节)	(10 节)
			BSL1415S : 15 BSL1415 : 15 BSL1415X : 15 BSL1420 : 20 BSL1425 : 25 BSL1430C : 30	BSL1430 : 20 BSL1440 : 26 BSL1450 : 32 BSL1460 : 38	BSL1815S : 15 BSL1815 : 15 BSL1815X : 15 BSL1820 : 20 BSL1825 : 25 BSL1830C : 30 BSL1850C : 32	BSL1830 : 20 BSL1840 : 26 BSL1850 : 32 BSL1860 : 38	BSL36A18 : 32 BSL36B18 : 52
USB	充电电压	V	5				
	充电电流	A	2				

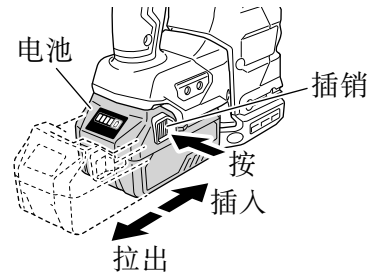
注：

充电时间可能会因环境温度和电源电压而异。

4. 从电源插座拔下充电器的电源线。
5. 握紧充电器并取出电池。

注：

充电后，先将电池从充电器中取出，然后妥善保管。

关于新电池的放电。

新电池内部的化学物质未被激活或电池长时间不使用时，初次或第二次使用时需要将其放电至较低电量。这只是暂时现象，将电池充电 2–3 次即可恢复为充电所需的正常时间。

较长时间保持电池性能的方法

(1) 在电池电力完全耗尽之前进行充电。

感到电动工具的能力变弱时，请停止使用并给电池充电。若您继续使用电动工具并耗尽电力，电池可能会损坏或其使用寿命缩短。

(2) 避免在高温环境中充电。

使用后可充电电池的温度将迅速升高。若使用后立即对这种电池进行充电，其内部化学物质会劣化，电池使用寿命将缩短。请稍等片刻，待电池冷却后再进行充电。

注意！

- 如果电池长时间放置在阳光直射的地方或者刚刚使用完毕时，电池会变热。如果此时对电池充电，充电器的充电指示灯会点亮 0.3 秒钟，然后熄灭 0.3 秒钟（熄灭 0.3 秒钟）。此时请等待电池冷却后再开始充电。
- 充电指示灯闪动（闪动间隔为 0.2 秒钟）时，请检查充电器的电池连接器内是否有异物并加以清除。如没有异物，则可能是电池或充电器发生了故障。请将其送往当地授权服务中心。
- 因内置的微电脑需要约 3 秒钟才能确认正用 UC18YSL3 充电的电池已被取出，因此请等待 3 秒钟后再重新插入电池继续充电。如果在不到 3 秒内就插入电池，则电池可能充电不正常。

USB 设备的充电方法

警告！

- 使用之前请检查 USB 连接线缆是否有破损或损坏。
使用有破损或损坏的 USB 线缆可能会导致冒烟或着火。
- 不使用产品时，请用橡胶盖封好 USB 端口。
USB 端口中落入灰尘等可能会导致冒烟或着火。

注：

- USB 充电过程中，可能会有偶尔暂停。
- USB 设备未充电时，请将充电器上拔下 USB 设备。
否则不仅会减少 USB 设备的电池寿命，还会导致意外事故。
- 根据设备类型，可能无法对部分 USB 设备进行充电。



图 7

(1) 选择充电方式

根据所选的充电方式，将电池插入充电器或连接电源线插入插座。

- 将 USB 设备插入插座进行充电
(图 7-a)。
- 将 USB 设备和电池插入插座进行充电。
(图 7-b)

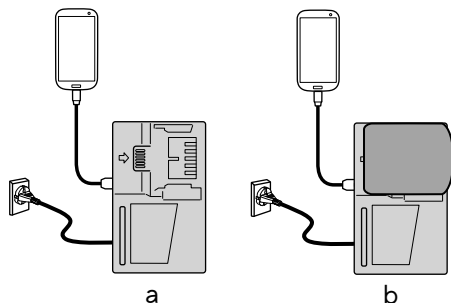
(2) 连接 USB 线缆。(图 8)

拨下橡胶盖并将市售的 USB 线缆（匹配充电的设备）紧紧插入 USB 端口。



图 8

(3) 充电完成时

- 检查 USB 设备以检验充电状态。
- 从插座中拔下电源线。(图 9)
- 用橡胶盖盖住 USB 端口。

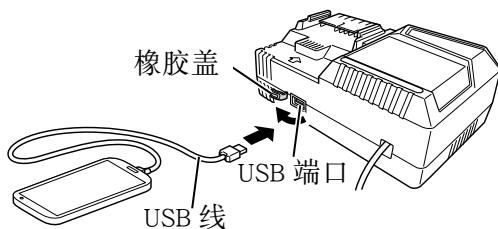

图 9

作业之前

1. 确认环境条件

确认工作场所条件合适，且符合规定的预防措施。

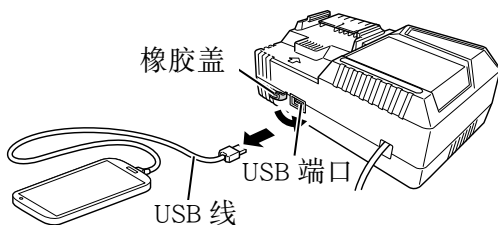
2. 安装侧柄 (图 10)

- (1) 转动侧手柄的握把将其拧松，并将其推动直至其接触到齿轮盖。
- (2) 将侧柄调整至最便于使用的角度，然后旋紧侧柄的夹卡，将其锁紧。



图 10

中文

3. 安装钻头 (图 11, 图 12)

注意!

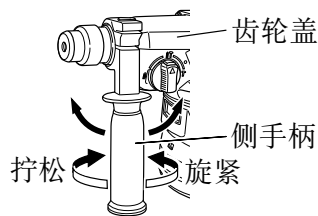
为避免意外事故, 请务必关闭开关。

注:

当使用钻头等工具时, 请务必使用本公司原装配件。

(1) 清洁钻头柄。

(2) 旋转钻头将其插入钻头夹盘直至插锁插紧。

(图 11)

在钻头安装时, 无需调节夹卡。

(3) 拉钻头以检查是否完全插紧。

(4) 卸下钻头时, 首先请按箭头所示方向将夹卡完全拉出, 然后将钻头从夹卡拉下。

(图 12)

4. 安装集尘杯和集尘器 (B) (选购附件) (图 13、图 14)

使用电动锤钻进行头上工作时, 请装上集尘杯和集尘器 (B), 以减少灰尘的掉下, 便于操作。

○ 集尘杯的安装方法

请按照图 13 所示方法, 将集尘杯装在钻头上使用。使用粗径钻头时, 请用本电动锤钻将集尘杯的中心孔开大。

○ 集尘器 (B) 的安装方法

使用集尘器 (B) 时, 请将集尘器 (B) 与夹卡上的槽对准后, 将集尘器 (B) 从钻头的顶端插进去 (图 14)。

注意!

○ 集尘杯和集尘器 (B) 是专门用于混凝土的钻孔, 请勿用于金属、木材的钻孔。

○ 请将集尘器 (B) 完全插入主机的夹盘部。

当集尘器 (B) 与混凝土表面有一段距离的状态下, 打开电动锤钻开关进行工作时, 集尘器 (B) 会跟钻头同时旋转。因此, 请务必将集尘杯紧压在混凝土表面上后再打开开关进行钻孔工作。(如将集尘器 (B) 用于全长 190mm 以上的钻头时, 集尘器 (B) 便无法贴紧混凝土表面而旋转。因此, 请将集尘器 (B) 与全长 166mm, 160mm, 110mm 的钻头配套使用。)

○ 每钻 2-3 个孔后, 请将粉尘丢掉。

○ 更换钻头时, 请卸下集尘器 (B) 以后再进行。



图 11



图 12

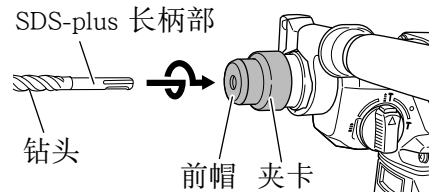

图 13

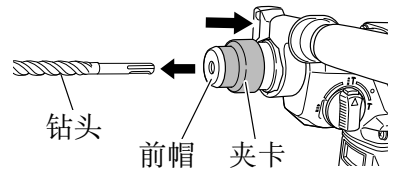

图 14

5. 选择螺丝钻头

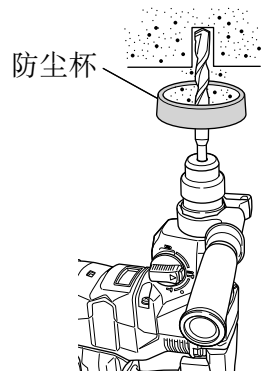
为了避免螺丝头或钻头被损坏,旋螺丝时一定要使用与螺丝直径相配的钻头。

6. 检查钻头的旋转方向 (图 15)

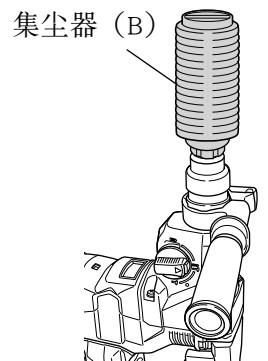
按按钮的 R (右) 侧,钻头会顺时针转 (从后方看)。(图 15)。

按按钮的 L (左) 侧,钻头会逆时针转。

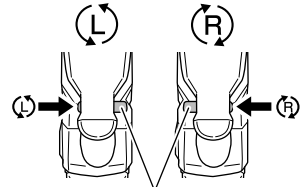

按钮

图 15

注意!

在电动工具运转期间,无法切换按钮。要切换按钮时,先停止电动工具运转,然后再设定按钮。

7. 剩余电池电量指示灯

可以按下剩余电池电量指示灯开关点亮指示灯,查看电池的剩余电量。(图 16, 第 18 页的表 4)

按住剩余电池电量指示灯开关约 3 秒后,指示灯将熄灭。

环境温度和电池状态可能会对剩余电池电量产生轻微的影响,因此,建议您仅将指示灯作为参考。

此外,电动工具或充电器上的剩余电池电量指示灯可能有所不同。

剩余电池电
量指示灯

剩余电池电
量指示灯开关







图 16

表 4

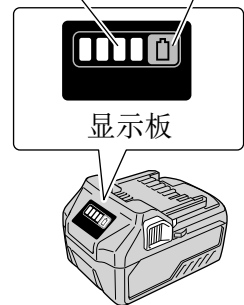
指示灯状态	电池剩余电量
	点亮； 电池剩余电量超过 75%
	点亮； 电池剩余电量为50%—75%
	点亮； 电池剩余电量为25%—50%
	点亮； 电池剩余电量不到 25%
	闪烁； 电池剩余电量即将耗尽。请尽快对电池进行充电。
	闪烁； 因高温暂停输出从电动工具中取下电池，让电池完全冷却。
	闪烁； 因失败或故障暂停输出。电池可能出现故障，请与经销商联系。

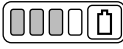
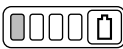
环境温度和电池特性不同，则所显示的电池剩余电量也会有些许不同，以上内容仅供参考。

8. 指示灯（主机）

使用中，当电池剩余电量不足时，指示灯将点亮。（图 17）

注：

- 请勿对开关面板施加强烈冲击或将其损坏，否则可能会导致故障。
- 为了节约电池用电，按住电池余量指示开关时电池余量指示灯才点亮。

9. LED 灯使用方法

拔出开关后，LED 灯将自动点亮工具尖头部分（图 18）。

开关松开后，LED 灯将会自动关闭 10 秒钟。



图 17



图 18

10. 更换钻头固定器或钻头卡盘固定器

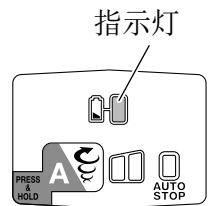
注意！

- 为避免意外事故，请务必关闭开关，并取出电池。
- 为避免在事故中受伤，请在更换夹盘前取下钻头工具。

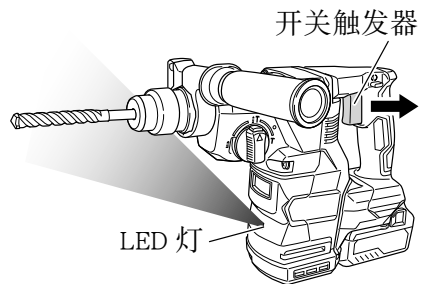
请按照以下操作步骤拆卸或安装钻头或钻头卡盘固定器。

< 拆卸 >

请按箭头所示方向旋转锁定夹卡，并拉出钻头固定器或钻头卡盘固定器（图 19）。（如果很难拉出钻头固定器或钻头卡盘固定器，请将选择杆对准 **T** 记号并旋转锁定夹卡，将其拉出。）

< 安装 >

- (1) 使锁定夹卡与齿条吻合。
- (2) 推入锁定夹卡，并按照锁定夹卡上显示的箭头方向进行旋转（图 20）。
- (3) 试着拉出锁定夹卡，确认已安装牢固。



图 19



图 20

使用方法**注意！**

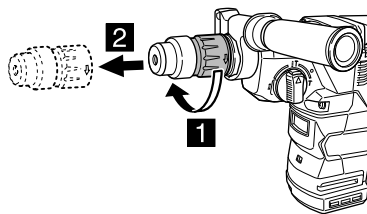
为避免意外事故，请务必关闭开关，并在安装或卸下钻头和其他零件时取出电池。工作休息和停止工作期间，应断开电源开关。

锂离子电池使用注意事项

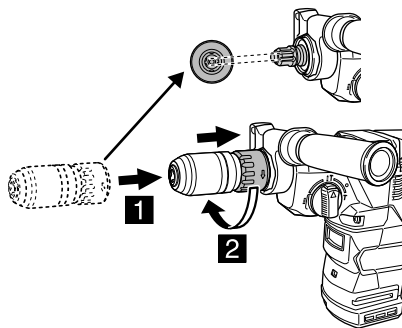
为延长使用期限，锂离子电池配备停止输出的保护功能。因此，如果工具过载，马达可能停止。不过，这只是保护功能作用的结果，而不是故障。在此情况下，松开工具的开关，消除造成过载的原因。

1. 开关操作

- 压下开关扳机，钻机钻动。松开扳机，钻机停止。
- 扳机拉出的量可以控制锤钻钻动速度。扳机拉出少许时，速度低，拉出多时，速度快。

中文

○ 松开扳机时，制动会即刻开始。

2. 旋钻+锤钻

按压按钮将选择杆逆时针方向转到标有“T”记号的位置时，锤钻就能以“旋钻+锤钻”的模式进行工作。(图 21)



图 21

(1) 安装钻头。

(2) 将钻头尖端放在钻孔位置，然后拉动触发开关。(图 22)

(3) 使用电动锤钻进行作业时，不需要用力推压。只要稍加按压，让钻碎的粉尘徐徐排出即可。

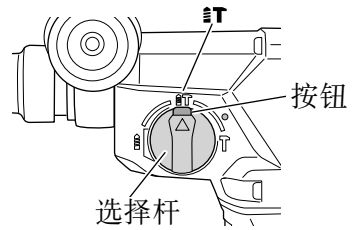



图 22

注意！

钻头碰到建筑物的钢筋时会立即停止转动。但电动锤钻又将随即转动(如图 22)，因此，必需握紧侧柄和操作柄。

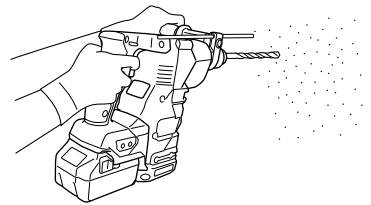
3. 旋钻

按压按钮将选择杆顺时针方向转到标有“”号的位置，锤钻就进行单纯旋钻。(图 23)

用配备的钻头夹盘和夹盘附加器(选购附件)钻木材或金属时，请按下列程序操作。



图 23

● DH1826DA

安装钻头夹盘和夹盘附加器：(图 24)

(1) 将钻头夹盘装配在夹盘附加器上。

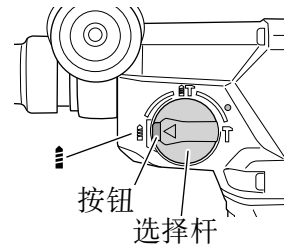
(2) SDS-plus 长柄与钻头相同。因此，装配 SDS-plus 长柄时，请参照“安装钻头”处的说明。



图 24

- 安装有钻头夹盘固定器的 DH1826DC
< 钻头的安装 / 拆卸 (图 25)>

注意！

- 为避免意外事故，请务必关闭开关并取出电池。
- 安装或卸下钻头时，请小心不要被钻头弄伤双手。
- 使用此工具进行混凝土钻孔以外的作业前，请务必必要拆下排屑装置。

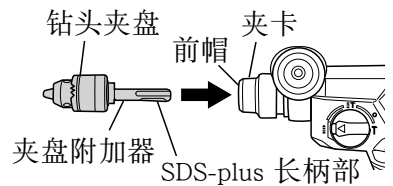

图 25

(1) 安装

将钻头安装在钻头夹盘固定器上后，用手紧紧握住环，并顺时针旋紧轴套（按“A”的方向）

如果在使用中发生松动，请紧紧旋紧轴套。轴套越紧，则夹持力越大。

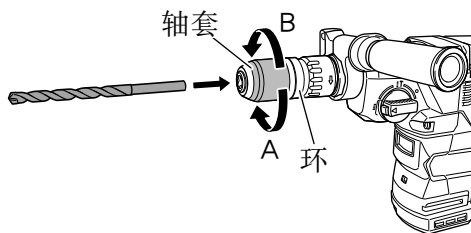
(2) 拆卸

用手紧紧握住环，逆时针拧松轴套（按“B”的方向）。

注意！

- 过分用力不仅无助于作业，而且会损坏钻头的刃尖，缩短钻头的寿命。
- 从钻孔中抽出钻头时，锤钻可能会折断，所以抽出时必须小心。
- 不要在单旋钻的功能下用锤钻钻锚孔或在混凝土上钻孔。
- 装有钻头夹盘和夹盘附加器时，不要在旋钻加锤击的功能下使用锤钻，这会严重缩短机器各个部件的寿命。

4. 旋机械螺丝时 (图 26)

- DH1826DA

首先把钻头插入夹盘附加器 (D) 端部的夹器中。

然后，按 4 (1), (2), (3), 中所描述的步骤把夹盘附加器 (D) 装在主机上，然后将钻头的刃尖放入螺丝头部的槽内，抓紧主机，旋紧螺丝。



图 26

- 安装有钻头夹盘固定器的 DH1826DC

用与安装钻头相同的方式将螺丝钻头安装到钻头夹盘固定器上。将螺丝钻头放入螺丝头槽内，然后打开开关，旋紧螺丝。

注意！

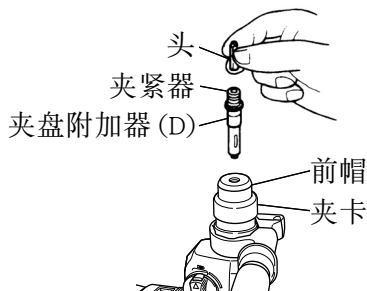
- 注意不要过分加长旋螺丝的时间，否则，过大的力会损坏螺丝。
- 旋螺丝时，锤钻要垂直对准螺丝头，否则，螺丝头或钻头会受损，或者旋转力不能被完全传给螺丝。
- 装有钻头和夹盘附加器时，不要在旋钻加锤击的功能下使用锤钻。
- 请务必在使用前拆下排屑装置。

5. 旋木螺丝时 (第21页的图 26)

(1) 选择适当的钻头

如果可能的话，请尽量使用十字头螺丝，因为钻头很容易滑出一字头螺丝的槽。

(2) 旋木螺丝

- 在旋木螺丝之前，在木板上开适当的先导孔，然后把钻头放入螺丝头部的槽内，缓缓地将螺丝旋进孔内。
- 低速转动锤钻一会儿直到木螺丝被旋进木板一部分，然后更紧地握住触发开关以便得到最佳旋转力。



图 27

注意！

- 在为木螺丝准备先导孔时，应特别注意木板的硬度。如果孔极小或极浅，用较大的力将螺丝旋进孔的话，有时会损坏木螺丝的螺纹。
- 请务必在使用前拆下排屑装置。

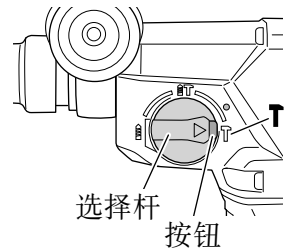

图 28

6. 锤击

按下按钮并将选择杆对准 **T** 记号，可以将电动锤钻设置为只锤钻模式 (图 27)。

● 安装有钻头固定器的 DH1826DC

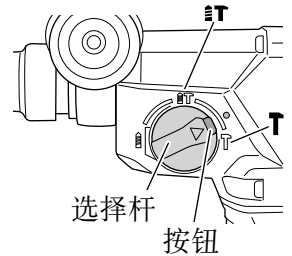
- (1) 安装尖钻或冷镗。
- (2) 按下按钮，并将选择杆调整至 **T** 记号和 **T** 记号的中间 (图 28)。旋转被释放，转动冷镗并将其调整到所需方向 (图 29)。
- (3) 旋转选择杆，使其对准 **T** 记号 (图 27)。尖钻头或冷镗被锁定



图 29

注意！

请务必在使用前拆下排屑装置。

7. 使用深度计 (图 30)

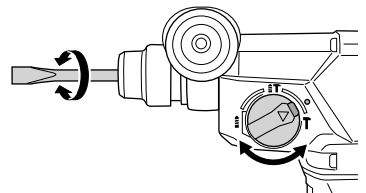
- (1) 旋松侧柄的圆头螺丝，把深度计插进侧柄上的安装孔。
- (2) 按孔深调节深度计的位置，然后旋紧圆头螺栓。



图 30

8. 钻头 (锥柄) 和锥柄附加器的使用

- (1) 把锥柄附加器安装在电动锤钻上。(图 31)

(图 31)

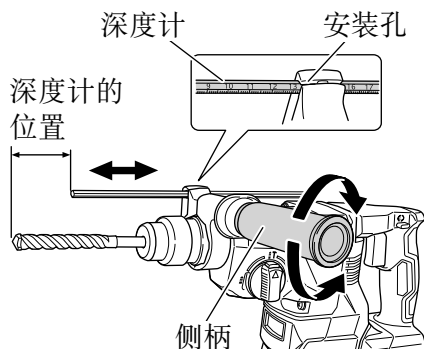
- (2) 把钻头 (锤柄) 安装在锤柄附加器上。(图 31)

- (3) 接通开关，按预定深度钻开一个孔口。

- (4) 拆卸钻头时，可将制销插入锥柄附加器的缝隙，把钻头放在台座上，用锥子敲打制销头部。(图 32)



图 31



图 32

怎么样使用取心钻具 (轻载用)

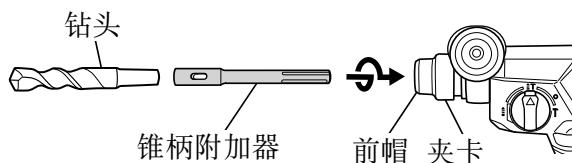
镗穿大孔时,可使用取心钻具 (轻载用) 进行作业。

这时候,必需使用选购件的中间销和取心钻柄。

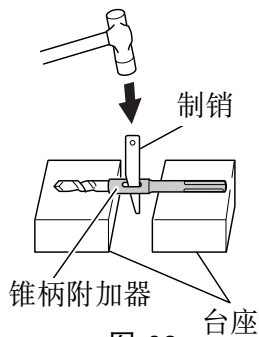
1. 安装

警告!

为避免意外事故,请务必关闭开关并断开电池。

- (1) 把取心钻具安装於取心钻柄 (图 33)。润滑取心钻柄的螺纹,可使拆解更加容易。

- (2) 把取心钻柄安装於锤钻 (图 34)。



图 33



图 34

中文

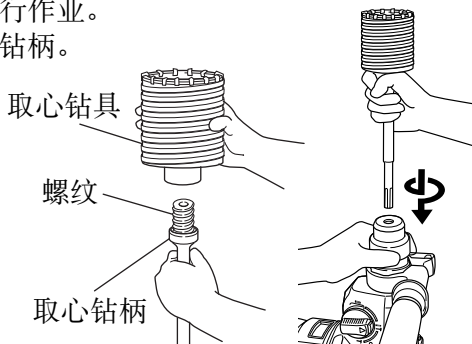
- (3) 把中间销插入於导板上直到受挡阻为止。
- (4) 把导板和取心钻具拼装起来，往右向或左向转动导板，直到朝下也不掉落（图 35）。

2. 怎么样进行钻孔（图 36）

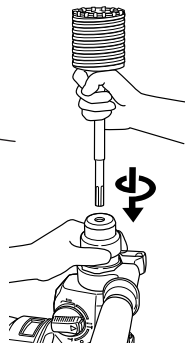
- (1) 安装电池。
- (2) 中间销里装有弹簧。垂直推压於墙壁或地板，使取心钻具尖端成为与之全面接触的状态，然后开动钻机。
- (3) 钻到大约 5mm 深度，钻孔位置即可确定。这时候，可存从取心钻具拆下中间销和导板。

警告！

- 拆下中间销和导板时，请关闭开关并断开电池。
- 过分用力不仅无助于作业，而且会损坏钻头的刀尖，缩短锤钻的寿命。

3. 拆卸（图 37）

亦可从锤钻拆下取心钻柄，然后拿稳取心钻具，用锤子强力锤击取心钻柄二至三次，让螺纹部松开，把取心钻具拆下。



图 35



图 36

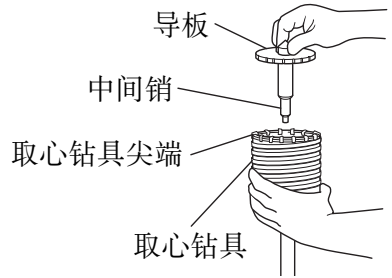

图 37

操作上的注意事项

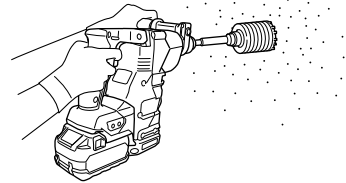
连续作业后须让电动工具休息片刻

- (1) 电动工具带有温度保护电路以保护马达。

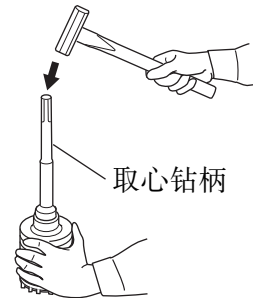
长时间连续作业可能会导致机器温度升高、触发温度保护电路并自动停止作业。

如果发生这种情况，请让电动工具冷却后再使用。

- (2) 请在长时间连续作业后或更换电池后，使使机器静止 15 分钟。如果在更换电池后立刻开始作业，马达和开关等的温度将会升高，结果导致烧毁。

选择操作模式

按下切换开关可以选择转速和自停功能。

○ 转速（低速模式 / 正常模式）（图 38）

可选择低速模式或正常模式，然后以所选速度操作工具。

○ 自停模式（开 / 关）（图 39）

本产品具有支持连续钻孔作业的自停功能。本功能具有用于存储钻孔作业时间（从开到关）的记忆模式，以及打开时若作业超时（超过存储的作业时间），将从第二次钻孔起自动停止电机的自停模式。



图 38



图 39

自停功能

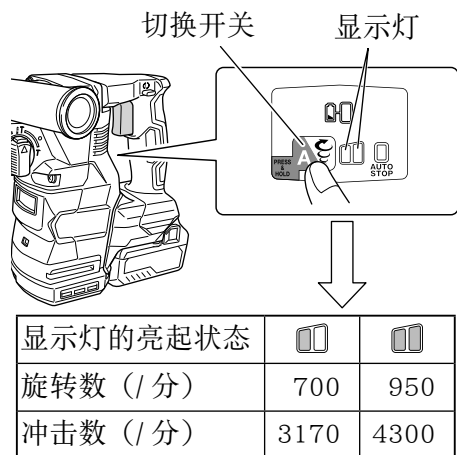
在选择模式下，长按切换开关两秒以上，即会进入记忆模式。（图 39）

（自停指示灯将同时闪烁。）

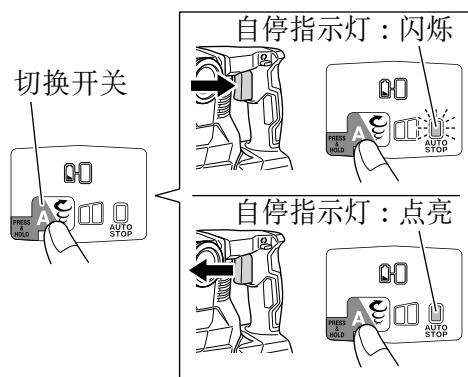
自停指示灯闪烁时进行钻孔。开 / 关切换的时间存储于工具中。

（自停指示灯将同时点亮。）

自停指示灯闪烁时进行钻孔。本工具会记录记忆存储时间，因此可连续钻孔，直至取消自停功能的自停模式为止。

再次按下切换开关两秒以上，即可取消自停功能。

（自停指示灯将同时熄灭。）

注意！

- 先将工具的刀头放在加工材料上，然后打开工具。
- 钻孔过程中的转速和开关拉出的幅度不会存储到记忆中。
- 自停模式下，进行一次完全钻孔。
- 即使在记忆存储时间内关闭，电机也会停止。
- 在记忆存储时间内关闭时，计数将被重置。如果您对其中部分钻孔的任务进行返工，则将重新计算记忆存储时间。
- 在取消前，自停功能将保持激活状态。

反作用力控制

本产品拥有反作用力控制 (RFC) 功能，可减轻机器震颤。

如果工具的刀头突然负载过重，可通过触发滑动离合器或用机器内安装的传感器来停止电机，以此来减轻机身震颤。

如果电机因控制器检测到负载过重而停止，则拉下开关时，显示灯将变为闪烁状态。此外，松开此开关后，指示灯将继续闪烁约三秒钟。在灯闪烁时电机将保持停止状态。

(图 40)

由于 RFC 功能可能未触发或因作业环境和条件而导致性能不足，因此操作时请勿使工具的刀头负载过重。



图 40

● 突然负担过重的可能原因

- ① 钻头陷入材料
 - ② 对钉子、金属或其他硬质物体的作用
 - ③ 涉及撬动或任何过度压力应用的工作
- 另外，包括任何上述原因组合的其他原因

● 当反作用力控制 (RFC) 启动

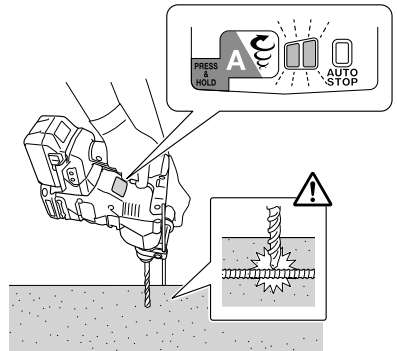
当反作用力控制 (RFC) 启动并且马达停止时，关闭工具的电源解除过度负担原因后继续操作。

关于保护功能

本工具具有内置的保护电路，可防止在异常情况下损坏本装置。显示灯将根据以下情况闪烁，并且本装置将停止操作。检查显示灯闪烁所指示的问题，并采取必要的步骤予以纠正。按切换开关时，请勿拉动开关。





图 41

表 5

显示灯闪烁	原因	解决方法
	因内部温度超限，操作停止。 (高温保护功能)	让装置冷却 15 至 30 分钟。 当温度下降且显示灯停止闪烁时， 请拉动开关扳机以恢复操作。
	工具刀头突然的负担过重激活了 RFC，从而停止了工具进一步的操作。 RFC（请参照第 26 页的“反作用力控制”）	松开开关扳机，直至显示灯停止闪烁为止。再次拉动开关扳机以恢复操作。 在继续操作前，请排除负担过重的原因。

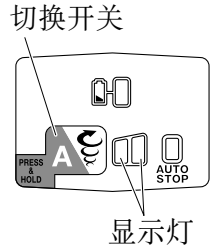
注：

虽已采取措施纠正问题，但显示灯仍可能继续闪烁。这种情况说明本装置可能需要维修。请联系购买本产品的经销商进行维修。

润滑

此手提电动锤钻应使用低粘度滑脂。这样，可长时间使用而无需更换滑脂。若滑脂从松动的螺丝中泄漏出来，请与最邻近的服务站联系，更换滑脂。如果在滑脂缺少的状态下继续使用，手提电动锤钻就会卡住，并因而缩短使用寿命。

注意！

此手提电动锤钻使用指定的滑脂，因此使用其他滑脂可能会对机器性能带来不利影响。请一定让服务站为你更换滑脂。

维护和检查

注意！

检查或维护前，请务必关闭开关并取出电池。

1. 检查工具

由于使用已经钝化的工具会降低效率并可能引起马达故障，因此一旦注意到磨损情况，就应及早磨快或更换工具。

2. 检查安装螺钉

要经常检查安装螺钉是否紧固妥善。若发现螺钉松了，应立即重新扭紧，否则会导致严重的事故。

3. 电动机的维护

电动机绕线是电动工具的“心脏部”应仔细检查有无损伤，是否被油液或水沾湿。

4. 检查端子（工具和电池）

确保端子上没有堆积削屑和灰尘。

在操作前、操作时和操作后需要时常检查。

注意！

请清除端子上的削屑或灰尘。

否则可能导致故障。

5. 清理外部

电动工具沾污时，用干软布或沾肥皂水的布擦拭。切勿使用氯溶液、汽油或稀释剂，以免塑胶部分溶化。

6. 清洁电池安装部位和电池

警告！

使用气枪进行清洁时，请务必戴好安全护目镜和防尘口罩。这样可保护您的眼睛并防止吸入四处飞扬的混凝土灰尘。

在混凝土上钻孔后，混凝土灰尘可能会积聚在如图所示的零件上。此时，请先用干布或气枪清除积聚的灰尘后，再使用该工具。（图 42、43）



图 42



图 43

- 注：**
清洁后，请确保可顺畅将电池安装到主机上或从主机上拆除。
- 注：**
如果使用积聚了混凝土灰尘的工具，可能会导致在使用期间电池掉落事故。此外，这可能会导致故障，或致使电池和端子接触不良。

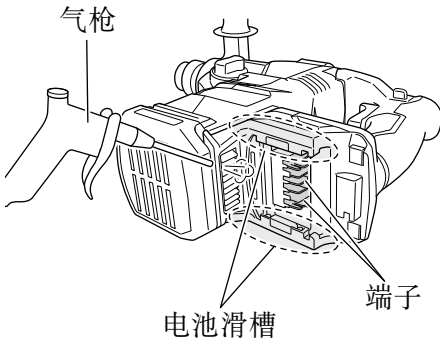
7. 收藏

电动工具应收藏于温度低于 40°C 和小孩拿不到的地方。

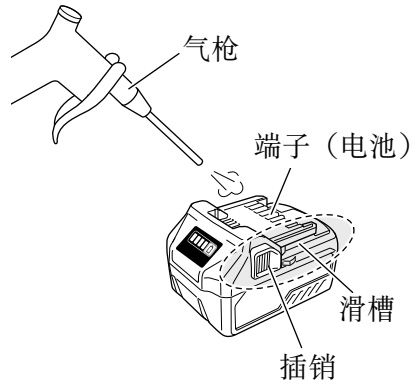
- 注：**
存放锂离子电池
在存放前请确保锂离子电池已完全充电。
电池在低电量的状态下长时间存放（3 个月或更长），可能会导致电池性能劣化，使用时间明显减少或无法进行充电。
但是，即使是使用时间明显减少的电池，通过反复充电和使用 2 ~ 5 次，有时也可恢复使用时间。
若反复充电和使用后电池的使用时间仍非常短，请认作为电池已达到了使用寿命并更换新的电池。

注意！

在操作和维修电动工具时，必须遵守贵国制定的安全的有关规则和标准。

关于 HiKOKI 牌无线电动工具的重要通知：

请确保始终使用我们指定的正版电池。如果使用我们指定以外的电池，或对电池进行拆卸和改动（例如拆卸和更换电池组件或其他内部部件），那么我们无法保证我们无线电动工具的安全性和使用性能。

故障排除

如果工具操作不正常，请使用下表中的检查步骤。如果未能解决问题，请向经销商或 HiKOKI 公司授权服务中心咨询。

1. 电动工具

现象	可能的原因	解决办法
工具无法运行	没有剩余电池电量	为电池充电
	电池没有牢固安装	按压电池直到听到咔嚓声
	电池安装槽的端子上以及电池滑槽上积聚了混凝土灰尘。	请用气枪或干布清洁积聚的灰尘。
工具突然停止	工具过度负重	避免因负载过重而引发的问题。
	反作用力控制已经启动	
	电池过热。	让电池冷却。
钻头 - 无法安装 - 掉落	安装部分的形状不匹配	对于 SDS-plus 长柄型号，使用直径在指定范围内的钻头。
无法顺利钻孔	电钻已经磨损	替换为新电钻
	旋转速度不合适	调整旋转速度（高 / 低）来匹配钻孔的材料
	钻头反向旋转	转换成正向旋转
螺丝头滑落或松开	钻头数量与螺丝尺寸不匹配	安装适合的钻头
	钻头已经磨损	替换为新钻头
无法安装电池	请尝试安装该工具指定的其他正版电池。	请安装多电压式或 BSL18xx 系列电池。

2. 充电器

现象	可能的原因	解决办法
充电指示灯快速闪烁紫色，电池未开始充电。	电池未完全插入。	请紧紧插入电池。
	电池端部或电池的连接处有异物。	将异物清除。
充电指示灯闪烁红色，电池未开始充电。	电池未完全插入。	请紧紧插入电池。
	电池过热。	如果继续放置，电池将在温度降低后自动开始充电，但此种情况可能会缩短电池使用寿命。建议将电池放置在通风良好的位置，在充电前避免阳光直射。
即使电池完全充电，电池的使用寿命也会逐渐缩短。	电池的使用寿命已耗尽。	请更换新电池。
电池的充电时间较长。	电池、充电器或周围环境的温度过低。	请在室内或温暖的环境中充电。
	充电器的排气孔堵塞，导致其内部部件过热。	请勿堵塞排气孔。
	冷却扇未运转。	请联系 HiKOKI 授权服务中心进行维修。
USB 电源灯熄灭，USB 设备停止充电。	电池剩余电量低。	用电量充足电池替换它。
		将充电器的电源插头插入电插座中。
即使 USB 设备充电完毕，USB 电源灯也不熄灭。	USB 电源灯点亮呈绿色，提示可进行 USB 充电。	这种情况不属于故障。
不清楚 USB 设备的充电状态如何或者是否充电完毕。	即使充电完毕，USB 电源灯也不熄灭。	检查正在充电的 USB 设备以确定其充电状态。

现象	可能的原因	解决办法
USB 设备在中途暂停充电。	使用电池作为电源对 USB 设备进行充电时，充电器插入电插座。	这种情况不属于故障。充电器与电源间存在差异时，USB 将暂停充电约 5 秒钟。
	使用电源插座作为电源对 USB 设备进行充电时，电池插入充电器。	
电池和 USB 设备同时充电时，USB 设备将在中途暂停充电。	电池已完全充电。	这种情况不属于故障。检查电池是否已充电完成时，充电器将暂停 USB 充电约 5 秒钟。
电池和 USB 设备同时充电时，USB 设备将无法开始充电。	电池剩余电量已不足。	这种情况不属于故障。电池电量达到一定程度时，USB 将自动开始充电。

选择附件

根据特定作业选择适合的附件。
有关详细信息请联系 HiKOKI 授权服务中心。

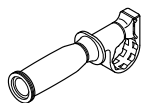

产品编号：335273
侧柄

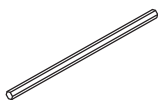

产品编号：303709
深度计

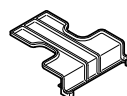

产品编号：329897
电池盖



36V (Li-ion)
电池

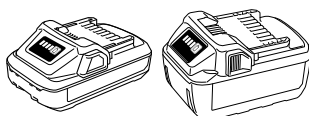

18V (Li-ion)
电池

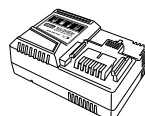

UC18YSL3
(14.4V-18V)
充电器

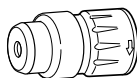

产品编号：375010
钻头夹

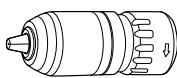

产品编号：377959
钻头夹刀柄

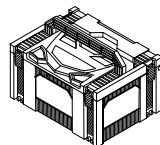

产品编号：337108
外壳（可堆叠）

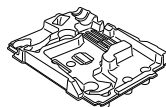

产品编号：379786
内托盘

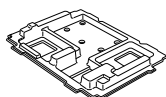

产品编号：379787
内托盘

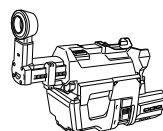

产品编号：
379135 (DH1826DA)
379139 (DH1826DC)
锤钻除尘器系统

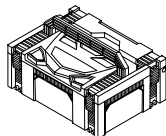

产品编号：336471
外壳（可堆叠）

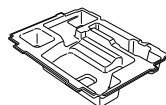

产品编号：379788
内托盘

产品编号：379136 (DH1826DA)
产品编号：379140 (DH1826DC)

中文

工具和适配器

详情请联系授权维修中心。

注：

如有规格变动，HiKOKI 概不负责。

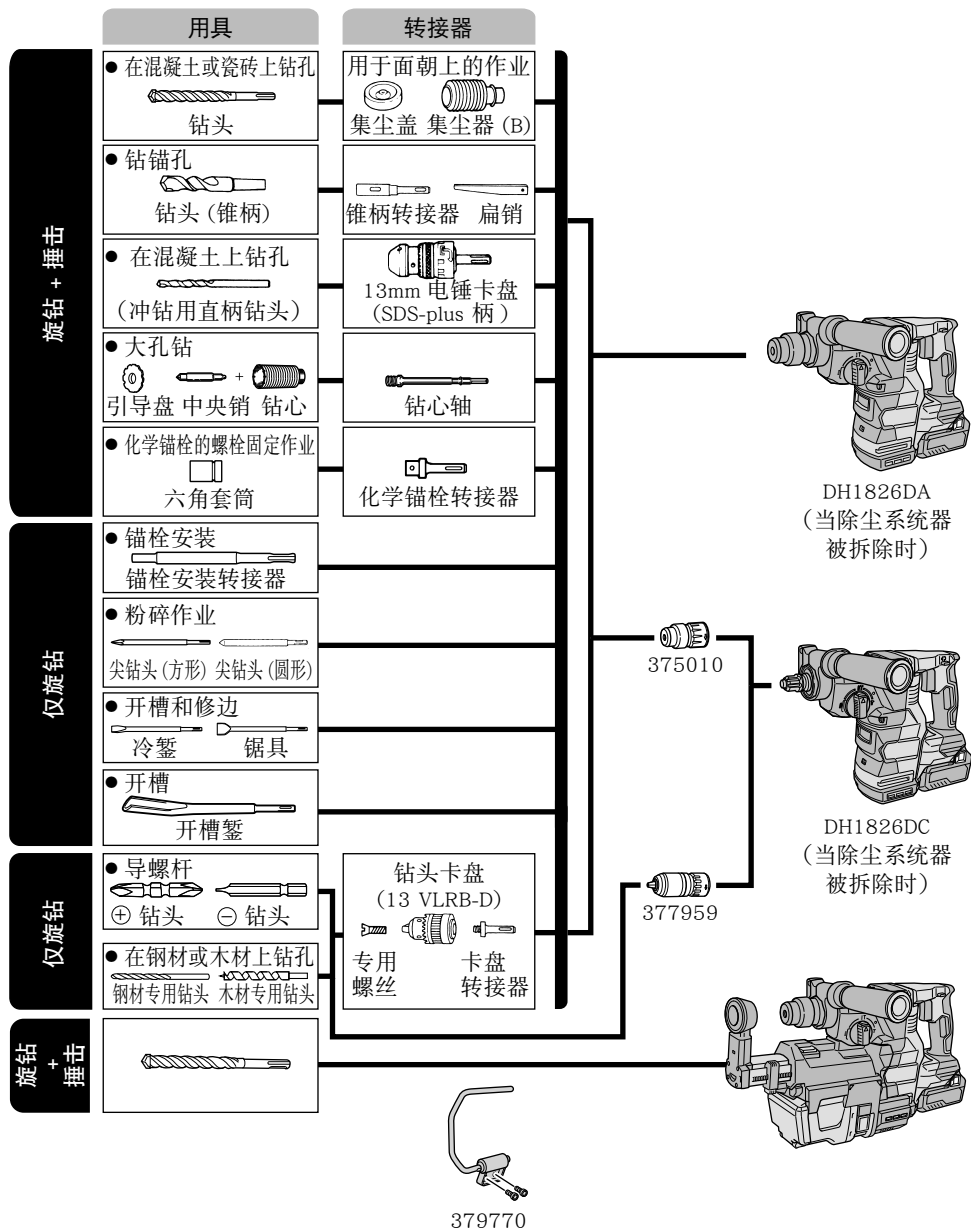

CONTENTS

GENERAL POWER TOOL SAFETY WARNINGS	35
CORDLESS ROTARY HAMMER SAFETY WARNINGS	38
ADDITIONAL SAFETY WARNINGS	39
CAUTION ON LITHIUM-ION BATTERY	41
REGARDING LITHIUM-ION BATTERY TRANSPORTATION	42
SYMBOL.....	43
SPECIFICATIONS	43
STANDARD ACCESSORIES	44
APPLICATIONS.....	44
BATTERY REMOVAL/INSTALLATION	45
CHARGING	45
HOW TO RECHARGE USB DEVICE	48
PRIOR TO OPERATION.....	50
HOW TO USE.....	54
HOW TO USE THE CORE BIT (FOR LIGHT LOAD)	58
OPERATIONAL CAUTIONS.....	59
SELECT OPERATION MODE	60
AUTO STOP FUNCTION.....	60
REACTIVE FORCE CONTROL	61
ABOUT THE PROTECTION FUNCTION	62
LUBRICATION	62
MAINTENANCE AND INSPECTION	63
TROUBLESHOOTING.....	65
SELECTING ACCESSORIES.....	68

GENERAL POWER TOOL SAFETY WARNINGS

WARNING

Read all safety warnings, instructions, illustrations and specifications provided with this power tool.

Failure to follow all instructions listed below may result in electric shock, fire and/or serious injury.

Save all warnings and instructions for future reference.

The term "power tool" in the warnings refers to your mains-operated (corded) power tool or battery-operated (cordless) power tool.

1) Work area safety

a) Keep work area clean and well lit.

Cluttered or dark areas invite accidents.

b) Do not operate power tools in explosive atmospheres, such as in the presence of flammable liquids, gases or dust.

Power tools create sparks which may ignite the dust or fumes.

English

- c) **Keep children and bystanders away while operating a power tool.**
Distractions can cause you to lose control.

2) Electrical safety

- a) **Power tool plugs must match the outlet.**
Never modify the plug in any way.
Do not use any adapter plugs with earthed (grounded) power tools.
Unmodified plugs and matching outlets will reduce risk of electric shock.
- b) **Avoid body contact with earthed or grounded surfaces, such as pipes, radiators, ranges and refrigerators.**
There is an increased risk of electric shock if your body is earthed or grounded.
- c) **Do not expose power tools to rain or wet conditions.**
Water entering a power tool will increase the risk of electric shock.
- d) **Do not abuse the cord. Never use the cord for carrying, pulling or unplugging the power tool.**
Keep cord away from heat, oil, sharp edges or moving parts.
Damaged or entangled cords increase the risk of electric shock.
- e) **When operating a power tool outdoors, use an extension cord suitable for outdoor use.**
Use of a cord suitable for outdoor use reduces the risk of electric shock.
- f) **If operating a power tool in a damp location is unavoidable, use a residual current device (RCD) protected supply.**
Use of an RCD reduces the risk of electric shock.

3) Personal safety

- a) **Stay alert, watch what you are doing and use common sense when operating a power tool.**
Do not use a power tool while you are tired or under the influence of drugs, alcohol or medication.
A moment of inattention while operating power tools may result in serious personal injury.
- b) **Use personal protective equipment. Always wear eye protection.**
Protective equipment such as a dust mask, non-skid safety shoes, hard hat or hearing protection used for appropriate conditions will reduce personal injuries.
- c) **Prevent unintentional starting. Ensure the switch is in the off-position before connecting to power source and/or battery pack, picking up or carrying the tool.**
Carrying power tools with your finger on the switch or energising power tools that have the switch on invites accidents.
- d) **Remove any adjusting key or wrench before turning the power tool on.**
A wrench or a key left attached to a rotating part of the power tool may result in personal injury.
- e) **Do not overreach. Keep proper footing and balance at all times.**
This enables better control of the power tool in unexpected situations.

- f) **Dress properly. Do not wear loose clothing or jewellery. Keep your hair, clothing and gloves away from moving parts.**
Loose clothes, jewellery or long hair can be caught in moving parts.
- g) **If devices are provided for the connection of dust extraction and collection facilities, ensure these are connected and properly used.**
Use of dust collection can reduce dust-related hazards.
- h) **Do not let familiarity gained from frequent use of tools allow you to become complacent and ignore tool safety principles.**
A careless action can cause severe injury within a fraction of a second.

4) **Power tool use and care**

- a) **Do not force the power tool. Use the correct power tool for your application.**
The correct power tool will do the job better and safer at the rate for which it was designed.
- b) **Do not use the power tool if the switch does not turn it on and off.**
Any power tool that cannot be controlled with the switch is dangerous and must be repaired.
- c) **Disconnect the plug from the power source and/or remove the battery pack, if detachable, from the power tool before making any adjustments, changing accessories, or storing power tools.**
Such preventive safety measures reduce the risk of starting the power tool accidentally.
- d) **Store idle power tools out of the reach of children and do not allow persons unfamiliar with the power tool or these instructions to operate the power tool.**
Power tools are dangerous in the hands of untrained users.
- e) **Maintain power tools and accessories. Check for misalignment or binding of moving parts, breakage of parts and any other condition that may affect the power tool's operation.**
If damaged, have the power tool repaired before use.
Many accidents are caused by poorly maintained power tools.
- f) **Keep cutting tools sharp and clean.**
Properly maintained cutting tools with sharp cutting edges are less likely to bind and are easier to control.
- g) **Use the power tool, accessories and tool bits etc. in accordance with these instructions, taking into account the working conditions and the work to be performed.**
Use of the power tool for operations different from those intended could result in a hazardous situation.
- h) **Keep handles and grasping surfaces dry, clean and free from oil and grease.**
Slippery handles and grasping surfaces do not allow for safe handling and control of the tool in unexpected situations.

5) **Battery tool use and care**

- a) **Recharge only with the charger specified by the manufacturer.**
A charger that is suitable for one type of battery pack may create a risk of fire when used with another battery pack.

English

- b) **Use power tools only with specifically designated battery packs.**
Use of any other battery packs may create a risk of injury and fire.
 - c) **When battery pack is not in use, keep it away from other metal objects, like paper clips, coins, keys, nails, screws or other small metal objects, that can make a connection from one terminal to another.**
Shorting the battery terminals together may cause burns or a fire.
 - d) **Under abusive conditions, liquid may be ejected from the battery; avoid contact. If contact accidentally occurs, flush with water. If liquid contacts eyes, additionally seek medical help.**
Liquid ejected from the battery may cause irritation or burns.
 - e) **Do not use a battery pack or tool that is damaged or modified.**
Damaged or modified batteries may exhibit unpredictable behaviour resulting in fire, explosion or risk of injury.
 - f) **Do not expose a battery pack or tool to fire or excessive temperature.**
Exposure to fire or temperature above 130 °C may cause explosion.
 - g) **Follow all charging instructions and do not charge the battery pack or tool outside the temperature range specified in the instructions.**
Charging improperly or at temperatures outside the specified range may damage the battery and increase the risk of fire.
- 6) **Service**
- a) **Have your power tool serviced by a qualified repair person using only identical replacement parts.**
This will ensure that the safety of the power tool is maintained.
 - b) **Never service damaged battery packs.**
Service of battery packs should only be performed by the manufacturer or authorized service providers.

CAUTION

Keep children and infirm persons away.

When not in use, tools should be stored out of reach of children and infirm persons.

CORDLESS ROTARY HAMMER SAFETY WARNINGS

1. **Wear ear protectors.**
Exposure to noise can cause hearing loss.
2. **Use the auxiliary handle(s), if supplied with the tool.**
Loss of control can cause personal injury.
3. **Hold power tool by insulated gripping surfaces, when performing an operation where the cutting accessory may contact hidden wiring.**
Cutting accessory contacting a “live” wire may make exposed metal parts of the power tool “live” and could give the operator an electric shock.

Safety instructions when using long drill bits with rotary hammers

4. **Always start drilling at low speed and with the bit tip in contact with the workpiece.**
At higher speeds, the bit is likely to bend if allowed to rotate freely without contacting the workpiece, resulting in personal injury.
5. **Apply pressure only in direct line with the bit and do not apply excessive pressure.**
Bits can bend causing breakage or loss of control, resulting in personal injury.

ADDITIONAL SAFETY WARNINGS

1. **Do not allow foreign matter to enter the hole for connecting the rechargeable battery.**
2. **Never disassemble the rechargeable battery and charger.**
3. **Never short-circuit the rechargeable battery. Shortcircuiting the battery will cause a great electric current and overheat. It results in burn or damage to the battery.**
4. **Do not dispose of the battery in fire. If the battery is burnt, it may explode.**
5. **When using this unit continuously, the unit may overheat, leading to damage in the motor and switch. Please leave it without using it for approximately 15 minutes.**
6. **Do not insert object into the air ventilation slots of the charger. Inserting metal objects or inflammables into the charger air ventilation slots will result in electrical shock hazard or damaged charger.**
7. **Bring the battery to the shop from which it was purchased as soon as the post-charging battery life becomes too short for practical use. Do not dispose of the exhausted battery.**
8. **Before starting to break, chip or drill into a wall, floor or ceiling, thoroughly confirm that such items as electric cables or conduits are not buried inside.**
9. **Ensure that the power switch is in the OFF position. If the battery is installed while the power switch is in the ON position, the power tool will start operating immediately, which could cause a serious accident.**
10. **Do not touch the bit during or immediately after operation. The bit becomes very hot during operation and could cause serious burns.**
11. **Always hold the body handle and side handle of the power tool firmly. Otherwise the counterforce produced may result in inaccurate and even dangerous operation.**
12. **Wear a dust mask**
Do not inhale the harmful dusts generated in drilling or chiseling operation. The dust can endanger the health of yourself and bystanders.
13. **Make sure that the battery is installed firmly. If it is at all loose it could come off and cause an accident.**
14. **To prevent accidents, make sure to turn the switch off and pull out the battery before changing accessories, storing, carrying or when not using the tools.**
15. **Mounting the drill bit**
 - **To prevent accidents, make sure to turn the switch off and pull out the battery.**
 - **When using tools such as bull points, drill bits, etc., make sure to use the genuine parts designated by our company.**
 - **Clean the shank portion of the drill bit.**
 - **Check the latching by pulling on the drill bit.**

English

16. Operate the change lever only when the motor is at a full stop. Operating the change lever while the motor is running may cause the tip tool to unexpectedly rotate and result in an accident. (Fig. 21 on page 54)
17. Rotation + hammering
DH1826DC: Using drill bit holder (standard accessories)
When the drill bit touches construction iron bar, the bit will stop immediately and the rotary hammer will react to revolve. Therefore firmly tighten the side handle, hold the body handle and side handles.
18. Rotation only
DH1826DC: Using drill chuck holder (standard accessories)
 - To drill wood or metal material using the drill chuck and chuck adapter (optional accessories).
 - Not using dust extractor system
 - Do not apply excessive force during operation. Doing so will not only damage the tip of the drill bit, but also reduce the service life of the rotary hammer.
 - A drill bit can snap off upon penetrating a drilled hole. When the drill is near penetration, lighten the pressure on the rotary hammer and continue drilling until penetration is achieved.
 - Do not attempt to drill anchor holes or holes in concrete with the machine set in the rotation only function.
 - Do not attempt to use the rotary hammer in the rotation and striking mode with the drill chuck and chuck adapter attached. This would seriously shorten the service life of every component of the machine.
19. Hammering only
DH1826DC: Using drill bit holder (standard accessories)
 - Not using dust extractor system
20. Do not look directly into the light. Such actions could result in eye injury. Wipe off any dirt or grime attached to the lens of the LED light with a soft cloth, being careful not to scratch the lens. Scratches on the lens of the LED light can result in decreased brightness.
21. Make sure to securely hold the tool as shown in Fig. 1 during operation.

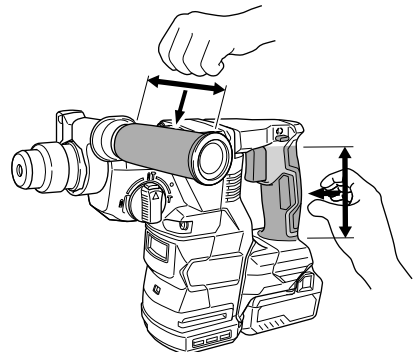

Fig. 1

CAUTION ON LITHIUM-ION BATTERY

To extend the lifetime, the lithium-ion battery equips with the protection function to stop the output.

In the cases of 1 to 3 described below, when using this product, even if you are pulling the switch, the motor may stop. This is not the trouble but the result of protection function.

1. When the battery power remaining runs out, the motor stops.
In such case, charge it up immediately.
2. If the tool is overloaded, the motor may stop. In this case, release the switch of tool and eliminate causes of overloading. After that, you can use it again.
3. If the battery is overheated under overload work, the battery power may stop. In this case, stop using the battery and let the battery cool. After that, you can use it again.

Furthermore, please heed the following warning and caution.

WARNING

In order to prevent any battery leakage, heat generation, smoke emission, explosion and ignition beforehand, please be sure to heed the following precautions.

1. Make sure that swarf and dust do not collect on the battery.
 - During work make sure that swarf and dust do not fall on the battery.
 - Make sure that any swarf and dust falling on the power tool during work do not collect on the battery.
 - Do not store an unused battery in a location exposed to swarf and dust.
 - Before storing a battery, remove any swarf and dust that may adhere to it and do not store it together with metal parts (screws, nails, etc.).
2. Do not pierce battery with a sharp object such as a nail, strike with a hammer, step on, throw or subject the battery to severe physical shock.
3. Do not use an apparently damaged or deformed battery.
4. Do not use the battery in reverse polarity.
5. Do not connect directly to an electrical outlets or car cigarette lighter sockets.
6. Do not use the battery for a purpose other than those specified.
7. If the battery charging fails to complete even when a specified recharging time has elapsed, immediately stop further recharging.
8. Do not put or subject the battery to high temperatures or high pressure such as into a microwave oven, dryer, or high pressure container.
9. Keep away from fire immediately when leakage or foul odor are detected.
10. Do not use in a location where strong static electricity generates.
11. If there is battery leakage, foul odor, heat generated, discolored or deformed, or in any way appears abnormal during use, recharging or storage, immediately remove it from the equipment or battery charger, and stop use.
12. Do not immerse the battery or allow any fluids to flow inside. Conductive liquid ingress, such as water, can cause damage resulting in fire or explosion. Store your battery in a cool, dry place, away from combustible and flammable items. Corrosive gas atmospheres must be avoided.

English

CAUTION

1. If liquid leaking from the battery gets into your eyes, do not rub your eyes and wash them well with fresh clean water such as tap water and contact a doctor immediately.
If left untreated, the liquid may cause eye-problems.
2. If liquid leaks onto your skin or clothes, wash well with clean water such as tap water immediately.
There is a possibility that this can cause skin irritation.
3. If you find rust, foul odor, overheating, discolor, deformation, and/or other irregularities when using the battery for the first time, do not use and return it to your supplier or vendor.

WARNING

If an electrically conductive foreign object enters the terminals of the lithium ion battery, a short-circuit may occur resulting in the risk of fire. Please observe the following matters when storing the battery.

- Do not place electrically conductive cuttings, nails, steel wire, copper wire or other wire in the storage case.
- Either install the battery in the power tool or store by securely pressing into the battery cover until the ventilation holes are concealed to prevent short-circuits (See Fig. 2).

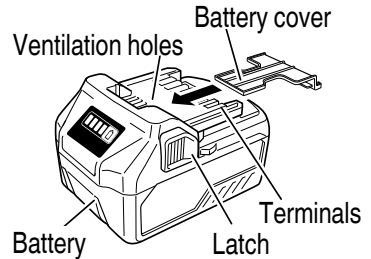

Fig. 2

REGARDING LITHIUM-ION BATTERY TRANSPORTATION

When transporting a lithium-ion battery, please observe the following precautions.

WARNING

Notify the transporting company that a package contains a lithium-ion battery, inform the company of its power output and follow the instructions of the transportation company when arranging transport.

- Lithium-ion batteries that exceed a power output of 100 Wh are considered to be in the freight classification of Dangerous Goods and will require special application procedures.
- For transportation abroad, you must comply with international law and the rules and regulations of the destination country.

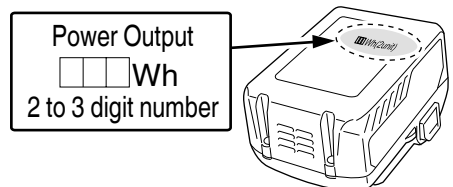



Fig. 3

SYMBOL

WARNING

The following show symbols used for the machine. Be sure that you understand their meaning before use.

	DH1826DA / DH1826DC: Cordless Rotary Hammer
	To reduce the risk of injury, user must read instruction manual.

SPECIFICATIONS

POWER TOOL

Model		DH1826DA	DH1826DC	DH1826DA*1	DH1826DC*1
Voltage		18 V			
No-load speed		0-950 /min			
Full-load impact rate		0-4300 /min			
Capacity	Concrete	26 mm		20 mm	
	Steel	13 mm		—	
	Wood	27 mm		—	
Battery*2	Model	BSL36A18			
	Type	Li-ion (10 cells)			
	Voltage	DC 36 V / 18 V (Automatic Switching*3)			
	Capacity	2.5 Ah / 5.0 Ah (Automatic Switching*3)			
Weight (with BSL36A18)		3.8 kg	4.0 kg	4.8 kg	5.0 kg

*1 with dust extractor system

*2 Existing batteries (BSL3660/3626X/3626/3625/3620 and BSL14xx series) cannot be used with this tool.

*3 The tool itself will automatically switch over.



CHARGER

Model	UC18YSL3
Charging voltage	14.4-18 V
Weight	0.6 kg

STANDARD ACCESSORIES

In addition to the main unit (1 unit), the package contains the accessories listed in the below.

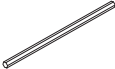
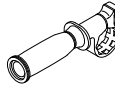
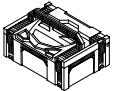
Table 1

	DH1826DA		DH1826DC	
	(NNPS)	(NNP)	(NNPS)	(NNP)
Dust extractor system ● For operating instructions, refer to the dust extractor system instruction manual.	1	—	1	—
 Depth gauge	1	1	1	1
 Side handle	1	1	1	1
 Case [No. 2]	2 (Main unit/ Other) (Dust extractor system)	1	2 (Main unit/ Other) (Dust extractor system)	1
 Drill bit holder	—	—	1	1
 Drill chuck holder	—	—	1	1

APPLICATIONS

Rotation and hammering function

- Drilling anchor holes
- Drilling holes in concrete
- Drilling holes in tile

Rotation only function (without dust extraction unit)

- Drilling in steel or wood (with optional accessories)
- Tightening machine screws, wood screws (with optional accessories)

Hammering only function (without dust extraction unit)

- Light-duty chiselling of concrete, groove digging and edging.

BATTERY REMOVAL/INSTALLATION

1. **Battery removal**
Hold the handle tightly and push the battery latches to remove the battery (see **Fig. 4** and **5**).

CAUTION

Never short-circuit the battery.

2. **Battery installation**
Insert the battery while observing its polarities (see **Fig. 5**).

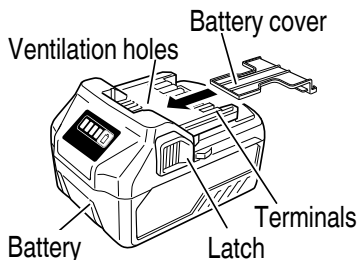

Fig. 4

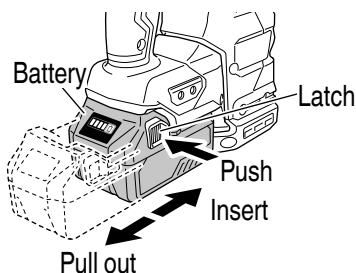

Fig. 5

CHARGING

Before using the power tool, charge the battery as follows.

1. **Connect the charger's power cord to the receptacle.**

When connecting the plug of the charger to a receptacle, the charge indicator lamp will blink in red (At 1- second intervals).

2. **Insert the battery into the charger.**

Firmly insert the battery into the charger as shown in **Fig. 6**.

3. **Charging**

When inserting a battery in the charger, the charge indicator lamp will blink in blue.

When the battery becomes fully recharged, the charge indicator lamp will light up in green. (See **Table 2** on **page 46**)

- (1) **Charge indicator lamp indication**

The indications of the charge indicator lamp will be as shown in **Table 2** on **page 46**, according to the condition of the charger or the rechargeable battery.

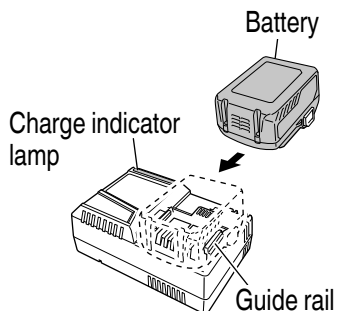





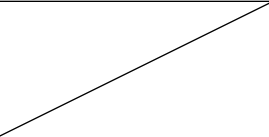



Fig. 6

Table 2

Indications of the charge indicator lamp				
Charge indicator lamp (RED / BLUE / GREEN / PURPLE)	Before charging	Blinks (RED)	Lights for 0.5 seconds. Does not light for 0.5 seconds. (off for 0.5 seconds) 	Plugged into power source
	While charging	Blinks (BLUE)	Lights for 0.5 seconds. Does not light for 1 second. (off for 1 second) 	Battery capacity at less than 50%
		Blinks (BLUE)	Lights for 1 second. Does not light for 0.5 seconds. (off for 0.5 seconds) 	Battery capacity at less than 80%
		Lights (BLUE)	Lights continuously 	Battery capacity at more than 80%
	Charging complete	Lights (GREEN)	Lights continuously  (Continuous buzzer sound: about 6 seconds)	
	Overheat standby	Blinks (RED)	Lights for 0.3 seconds. Does not light for 0.3 seconds. (off for 0.3 seconds) 	Battery overheated. Unable to charge. (Charging will commence when battery cools)
	Charging impossible	Flickers (PURPLE)	Lights for 0.1 seconds. Does not light for 0.1 seconds. (off for 0.1 seconds)  (Intermittent buzzer sound: about 2 seconds)	Malfunction in the battery or the charger

- (2) Regarding the temperatures and charging time of the rechargeable battery
The temperatures and charging time will become as shown in **Table 3**.

Table 3

Charger		UC18YSL3					
Battery	Type of battery	Li-ion					
	Temperatures at which the battery can be recharged	0°C – 50°C					
	Charging voltage	V	14.4		18		
	Charging time, approx. (At 20°C)	min.	BSL14xx series		BSL18xx series		Multi volt series
			(4 cells)	(8 cells)	(5 cells)	(10 cells)	(10 cells)
		BSL1415S: 15 BSL1415 : 15 BSL1415X: 15 BSL1420 : 20 BSL1425 : 25 BSL1430C: 30	BSL1430 : 20 BSL1440 : 26 BSL1450 : 32 BSL1460 : 38	BSL1815S: 15 BSL1815 : 15 BSL1815X: 15 BSL1820 : 20 BSL1825 : 25 BSL1830C: 30 BSL1850C: 32	BSL1830 : 20 BSL1840 : 26 BSL1850 : 32 BSL1860 : 38	BSL36A18: 32 BSL36B18: 52	
USB	Charging voltage	V	5				
	Charging current	A	2				

NOTE

The recharging time may vary according to the ambient temperature and power source voltage.

4. **Disconnect the charger's power cord from the receptacle.**
5. **Hold the charger firmly and pull out the battery.**

NOTE

Be sure to pull out the battery from the charger after use, and then keep it.

Regarding electric discharge in case of new batteries, etc.

As the internal chemical substance of new batteries and batteries that have not been used for an extended period is not activated, the electric discharge might be low when using them the first and second time. This is a temporary phenomenon, and normal time required for recharging will be restored by recharging the batteries 2–3 times.

English

How to make the batteries perform longer.

- (1) Recharge the batteries before they become completely exhausted.
When you feel that the power of the tool becomes weaker, stop using the tool and recharge its battery. If you continue to use the tool and exhaust the electric current, the battery may be damaged and its life will become shorter.
- (2) Avoid recharging at high temperatures.
A rechargeable battery will be hot immediately after use. If such a battery is recharged immediately after use, its internal chemical substance will deteriorate, and the battery life will be shortened. Leave the battery and recharge it after it has cooled for a while.

CAUTION

- **If the battery is charged while it is heated because it has been left for a long time in a location subject to direct sunlight or because the battery has just been used, the charge indicator lamp of the charger lights for 0.3 seconds, does not light for 0.3 seconds (off for 0.3 seconds). In such a case, first let the battery cool, then start charging.**
- **When the charge indicator lamp flickers (at 0.2-second intervals), check for and take out any foreign objects in the charger's battery connector. If there are no foreign objects, it is probable that the battery or charger is malfunctioning. Take it to your authorized Service Center.**
- **Since the built-in micro computer takes about 3 seconds to confirm that the battery being charged with UC18YSL3 is taken out, wait for a minimum of 3 seconds before reinserting it to continue charging. If the battery is reinserted within 3 seconds, the battery may not be properly charged.**

HOW TO RECHARGE USB DEVICE

WARNING

- **Prior to use, check the connecting USB cable for any defect or damage. Using a defective or damaged USB cable can cause smoke emission or ignition.**
- **When the product is not being used, cover the USB port with the rubber cover. Buildup of dust etc. in the USB port can cause smoke emission or ignition.**

NOTE

- There may be an occasional pause during USB recharging.
- When a USB device is not being charged, remove the USB device from the charger. Failure to do so may not only reduce the battery life of a USB device, but may also result in unexpected accidents.
- It may not be possible to charge some USB devices, depending on the type of device.

- (1) Select a charging method
Depending on the charge method selected, either the battery is inserted into the charger or the power cord is plugged into an outlet.
- Charging a USB device from a electrical outlet. **(Fig. 7-a)**
- Charging a USB device and battery from a electrical outlet. **(Fig. 7-b)**

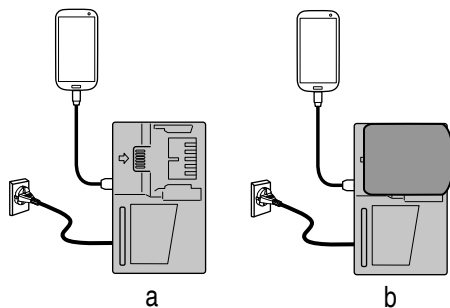

Fig. 7

- (2) Connect the USB cable. **(Fig. 8)**
Pull back the rubber cover and firmly plug in a commercially available USB cable (appropriate to the device being charged) into the USB port.

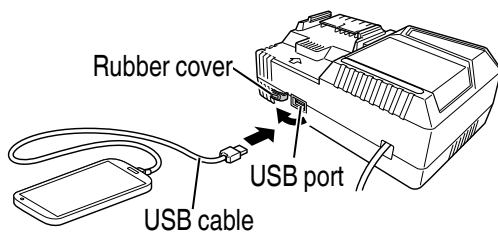

Fig. 8

- (3) When charging is completed
- To verify charge status, check the USB device.
- Unplug the power cord from the electrical outlet. **(Fig. 9)**
- Place the rubber cover over the USB port.

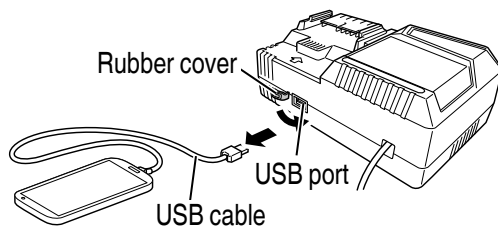

Fig. 9

PRIOR TO OPERATION

1. Confirming condition of the environment
Confirm that the work site is placed under appropriate conditions conforming to prescribed precautions.
2. Attaching the side handle (**Fig. 10**)
 - (1) Turn the grip of the side handle to loosen it and push it in until it comes in contact with the gear cover.
 - (2) Adjust the side handle to the angle that allows the easiest use, then turn the side handle's grip firmly to lock it place.
3. Mounting the drill bit (**Fig. 11, Fig. 12**)

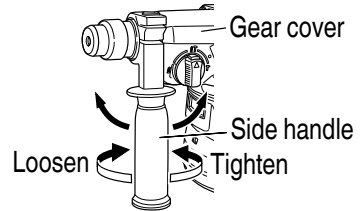

Fig. 10

CAUTION

To prevent accidents, make sure to turn the switch off.

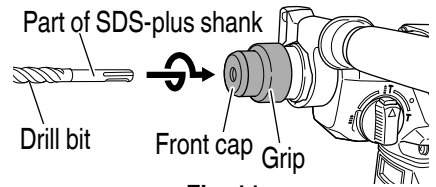

Fig. 11

NOTE

When using tools such as drill bits, etc., make sure to use the genuine parts designated by our company.

- (1) Clean the shank portion of the drill bit.
- (2) Insert the drill bit in a twisting manner into the tool holder until it latches itself. (**Fig. 11**)
The grip need not be adjusted during bit installation.
- (3) Check the latching by pulling on the drill bit.
- (4) To remove the drill bit, fully pull the grip in the direction of the arrow and pull out the drill bit. (**Fig. 12**)

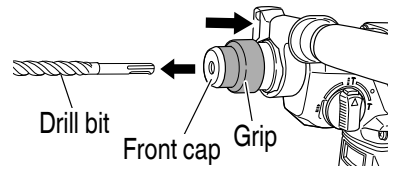

Fig. 12

4. Installation of dust cup or dust collector (B) (Optional accessories) (**Fig. 13, Fig. 14**)
When using a rotary hammer for upward drilling operations attach a dust cup or a dust collector (B) to collect dust or particles for easy operation.
- Installing the dust cup
Use the dust cup by attaching to the drill bit as shown in **Fig. 13**.
When using a bit which has big diameter, enlarge the center hole of the dust cup with this rotary hammer.
 - Installing dust collector (B)
When using dust collector (B), insert dust collector (B) from the tip of the bit by aligning it to the groove on the grip. (**Fig. 14**).

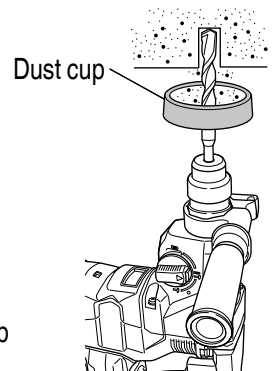

Fig. 13

CAUTION

- The dust cup and dust collector (B) are for exclusive use of concrete drilling work. Do not use them for wood or metal drilling work.
- Insert dust collector (B) completely into the chuck part of the main unit.
When turning the rotary hammer on while dust collector (B) is detached from a concrete surface, dust collector (B) will rotate together with the drill bit. Make sure to turn on the switch after pressing dust cup on the concrete surface. When using dust collector (B) attached to a drill bit that has more than 190 mm of overall length, dust collector (B) cannot touch the concrete surface and will rotate. Therefore, please use dust collector (B) by attaching to drill bits which have 166 mm, 160 mm, and 110 mm overall length.
- Dump particles after every two or three holes when drilling.
- Please replace the drill bit after removing dust collector (B).

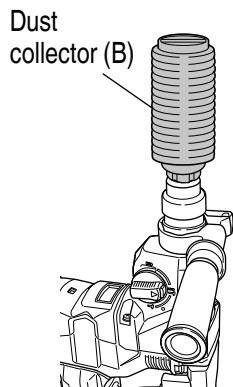

Fig. 14

5. Selecting the driver bit
Screw heads or bits will be damaged unless a bit appropriate for the screw diameter is employed to drive in the screws.
6. Confirm the direction of bit rotation (Fig. 15)
The bit rotates clockwise (viewed from the rear side) by pushing the R-side of the push button. (Fig. 15)
The L-side of the push button is pushed to turn the bit counterclockwise.

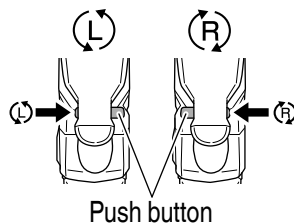

Fig. 15

CAUTION

The push button cannot be switched while the power tool is turning. To switch the push button, stop the power tool, then set the push button.

7. Remaining battery indicator
You can check the battery's remaining capacity by pressing the remaining battery indicator switch to light the indicator lamp. (Fig. 16, Table 4 on page 52)
The indicator will shut off approximately 3 seconds after the remaining battery indicator switch is pressed.
It is best to use the remaining battery indicator as a guide since there are slight differences such as ambient temperature and the condition of the battery.
Also, the remaining battery indicator may vary from those equipped to a tool or charger.

Remaining battery indicator lamp Remaining battery indicator switch

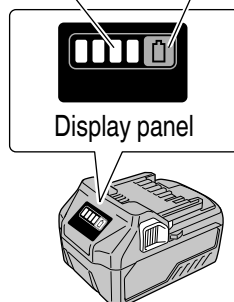
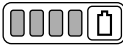
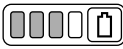
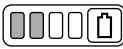

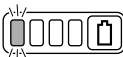



Fig. 16

Table 4

State of lamp	Battery Remaining Power
	Lights ; The battery remaining power is over 75%
	Lights ; The battery remaining power is 50%–75%.
	Lights ; The battery remaining power is 25%–50%.
	Lights ; The battery remaining power is less than 25%
	Blinks ; The battery remaining power is nearly empty. Recharge the battery soonest possible.
	Blinks ; Output suspended due to high temperature. Remove the battery from the tool and allow it to fully cool down.
	Blinks ; Output suspended due to failure or malfunction. The problem may be the battery so please contact your dealer.

As the remaining battery indicator shows somewhat differently depending on ambient temperature and battery characteristics, read it as a reference.

8. Indicator lamp (Main Unit)

During use, the indicator lamp will light when the remaining power of the battery is low. (Fig. 17)

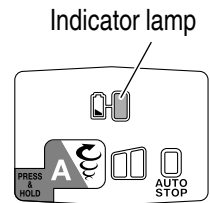

Fig. 17

NOTE

- Do not give a strong shock to the switch panel or break it. It may lead to a trouble.
- To save the battery power consumption, the remaining battery indicator lamp lights while pressing the remaining battery indicator switch.

9. How to use the LED light

While the switch is pulled, the LED light will automatically light up the tip portion of the tool. (Fig. 18)

The LED light will automatically turn off 10 seconds after the switch is released.

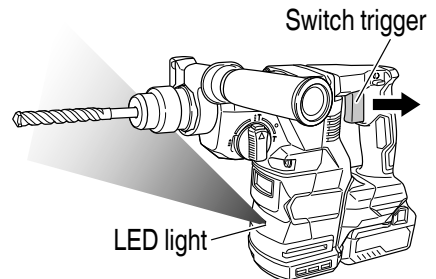

Fig. 18

10. Replacement of the drill bit holder or the drill chuck holder

CAUTION

- Prevent accidents, make sure to turn the switch off and disconnect the battery.
- To avoid an injury by accident, before replacing the chuck, remove the tipped tool.

Remove or install the drill bit or the drill chuck holder in the procedures below.

<Removal>

Turn the lock grip in the arrow direction shown on the lock grip and pull out the drill bit holder or the drill chuck holder (**Fig. 19**).

(If it is hard to pull out the drill bit holder or the drill chuck holder, align the change lever with the **T** mark and turn the lock grip to pull it out.)

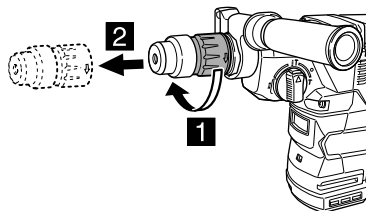

Fig. 19

<Installation>

- (1) Mesh the lock grip with spline.
- (2) Push in the lock grip, turning it in the arrow direction shown on the lock grip (**Fig. 20**).
- (3) To confirm that the lock grip is securely installed, tentatively try to pull out the lock grip.

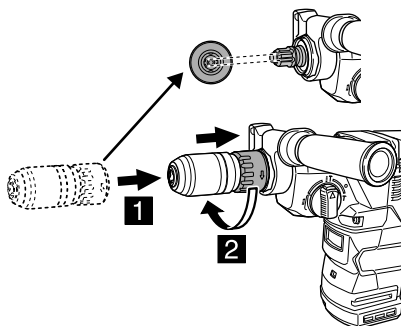

Fig. 20

HOW TO USE

CAUTION

To prevent accidents, make sure to turn the switch off and disconnect the battery when the drill bits and other various parts are installed or removed. The power switch should also be turned off during a work break and after work.

CAUTION on lithium-ion battery

To extend the lifetime, the lithium-ion battery equips with the protection function to stop the output. Therefore, if the tool is overloaded, the motor may stop. However, this is not the trouble but the result of protection function. In this case, release the switch of tool and eliminate the causes of overloading.

1. Switch operation

- When the switch trigger is depressed, the tool rotates. When the switch trigger is released, the tool stops.
- The rotational speed of the rotary hammer can be controlled by varying the amount that the switch trigger is pulled. Speed is low when the switch trigger is pulled slightly and increases as the switch trigger is pulled more.
- When releasing the switch trigger, the brake will be applied for immediate stopping.

2. Rotation + hammering

This rotary hammer can be set to rotation and hammering mode by pressing the push button and turning the change lever to the  T mark (Fig. 21).

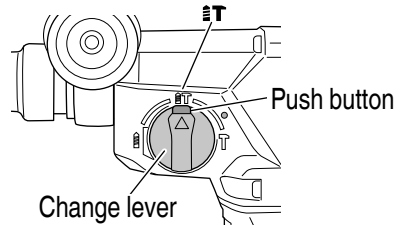

Fig. 21

- (1) Mount the drill bit.
- (2) Pull the trigger switch after applying the drill bit tip to the drilling position. (Fig. 22)
- (3) Pushing the rotary hammer forcibly is not necessary at all. Pushing slightly so that drill dust comes out gradually is just sufficient.

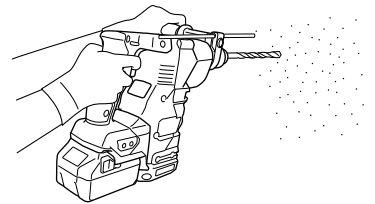



Fig. 22

CAUTION

When the drill bit touches construction iron bar, the bit will stop immediately and the rotary hammer will react to revolve. Therefore please grip the side handle and handle tightly as shown in Fig. 22.

3. Rotation only

This rotary hammer can be set to rotation only mode by pressing the push button and turning the change lever to the  mark (Fig. 23).

To drill wood or metal material using the drill chuck and chuck adapter (optional accessories), proceed as follows.

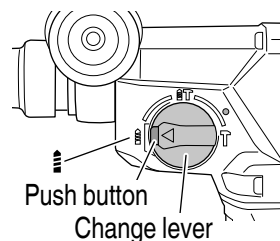

Fig. 23

● DH1826DA

Installing drill chuck and chuck adapter. (Fig. 24)

- (1) Attach the drill chuck to the chuck adapter.
- (2) The part of the SDS-plus shank is the same as the drill bit. Therefore, refer to the item of "Mounting the drill bit" for attaching it.

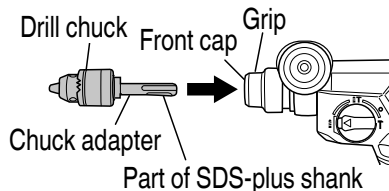

Fig. 24

● DH1826DC with drill chuck holder installed
<Installation/Removal of the drill bit (Fig. 25)>**CAUTION**

- Prevent accidents, make sure to turn the switch off and pull out the battery.
- When installing or removing the drill bit, be careful not to hurt hands with the drill bit.
- Be sure to remove the dust extraction unit before using the tool for work other than drilling holes in concrete.

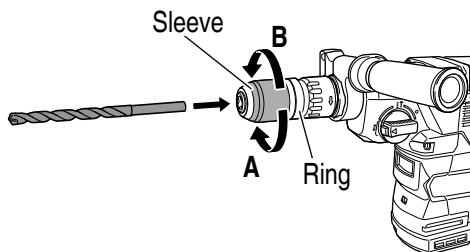

Fig. 25

(1) Installation

After inserting the drill bit in the drill chuck holder, hold firmly the ring by hand and tighten the sleeve by turning it clockwise (in the direction of "A")

If loosened in use, tighten strongly the sleeve. The harder you tighten the sleeve, the stronger the gripping force becomes.

(2) Removal

Hold firmly the ring by hand and loosen the sleeve by turning it counterclockwise in the direction of ("B").

CAUTION

- Application of force more than necessary will not only expedite the work, but will deteriorate the tip edge of the drill bit and reduce the service life of the rotary hammer in addition.
- Drill bits may snap off while withdrawing the rotary hammer from the drilled hole. For withdrawing, it is important to use a pushing motion.

English

- Do not attempt to drill anchor holes or holes in concrete with the machine set in the rotation only function.
- Do not attempt to use the rotary hammer in the rotation and striking function with the drill chuck and chuck adapter attached. This would seriously shorten the service life of every component of the machine.

4. When driving machine screws (Fig. 26)

● DH1826DA

First, insert the bit into the socket in the end of chuck adapter (D).

Next, mount chuck adapter (D) on the main unit using procedures described in 4 (1), (2), (3), put the tip of the bit in the slots in the head of the screw, grasp the main unit and tighten the screw.

● DH1826DC with drill chuck holder installed

In the same manner as the drill bit is installed, install the driver bit to the drill chuck holder. Apply the driver bit to the groove of screw head and turn on the switch to tighten the screw.

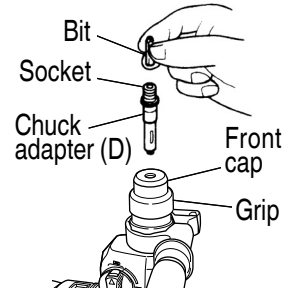

Fig. 26

CAUTION

- Exercise care not to excessively prolong driving time, otherwise, the screws may be damaged by excessive force.
- Apply the rotary hammer perpendicularly to the screw head when driving the screw; otherwise, the screw head or bit will be damaged, or driving force will not be fully transferred to the screw.
- Do not attempt to use the rotary hammer in the rotation and striking function with the chuck adapter and bit attached.
- Be sure to remove the dust extraction unit before use.

5. When driving wood screws (Fig. 26)

(1) Selecting a suitable driver bit

Employ plus-head screws, if possible, since the driver bit easily slips off the heads of minus-head screws.

(2) Driving in wood screws.

- Prior to driving in wood screws, make pilot holes suitable for them in the wooden board. Apply the bit to the screw head grooves and gently drive the screws into the holes.
- After rotating the rotary hammer at low speed for a while until the wood screw is partly driven into the wood, squeeze the trigger more strongly to obtain the optimum driving force.

CAUTION

- Exercise care in preparing a pilot hole suitable for the wood screw taking the hardness of the wood into consideration. Should the hole be excessively small or shallow, requiring much power to drive the screw into it, the thread of the wood screw may sometimes be damaged.
- Be sure to remove the dust extraction unit before use.

6. Hammering only

This rotary hammer can be set to hammering only mode by pressing the push button and turning the change lever to the **T** mark (Fig. 27).

● DH1826DC with drill bit holder installed

- (1) Mount the bull point or cold chisel.
- (2) Press the push button and set the change lever to middle of **T** mark and **T** mark (Fig. 28).
The rotation is released, turn the cold chisel and adjust it to desired position (Fig. 29).
- (3) Turn the change lever to **T** mark (Fig. 27).
Then bull point or cold chisel is locked.

CAUTION

Be sure to remove the dust extraction unit before use.

7. Using depth gauge (Fig. 30)

- (1) Loosen the knob on the side handle, and insert the depth gauge into the mounting hole on the side handle.
- (2) Adjust the depth gauge position according to the depth of the hole and tighten the knob securely.

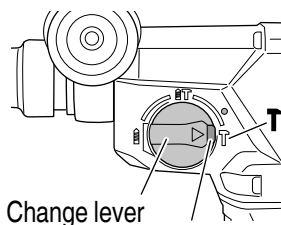

Change lever
Push button

Fig. 27

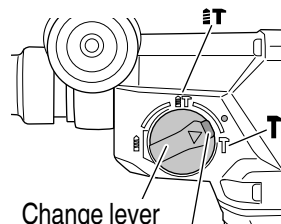

Change lever
Push button

Fig. 28

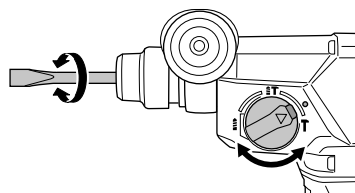

Fig. 29

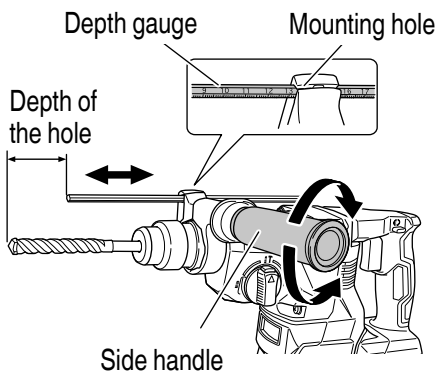

Fig. 30

English

8. How to use the drill bit (taper shank) and the taper shank adapter

- (1) Mount the taper shank adapter to the rotary hammer. (**Fig. 31**)
- (2) Mount the drill bit (taper shank) to the taper shank adapter. (**Fig. 31**)
- (3) Turn the switch ON, and drill a hole in prescribed depth.
- (4) To remove the drill bit (taper shank), insert the cotter into the slot of the taper shank adapter and strike the head of the cotter with a hammer supporting on the rests. (**Fig. 32**)

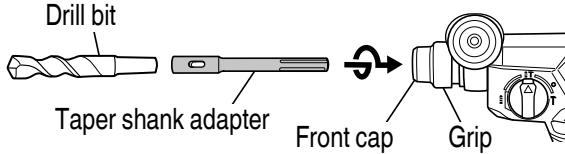

Fig. 31

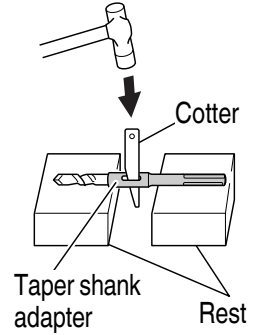

Fig. 32

HOW TO USE THE CORE BIT (FOR LIGHT LOAD)

When boring penetrating large holes use the core bit (for light loads). At that time use with the center pin and the core bit shank provided as optional accessories.

1. Mounting

WARNING

To prevent accidents, make sure to turn the switch off and disconnect the battery.

- (1) Mount the core bit to the core bit shank (**Fig. 33**).
Lubricate the thread of the core bit shank to facilitate disassembly.
- (2) Mount the core bit to the rotary hammer (**Fig. 34**).

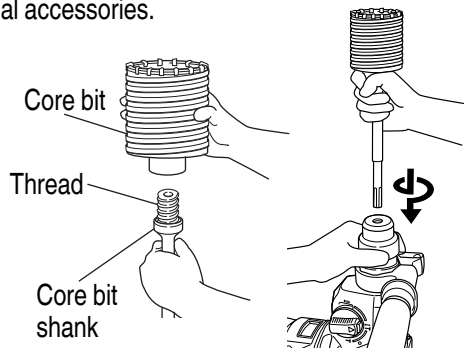

Fig. 33

Fig. 34

- (3) Insert the center pin into the guide plate until it stops.
- (4) Engage the guide plate with the core bit, and turn the guide plate to the left or the right so that it does not fall even if it faces downward (**Fig. 35**).

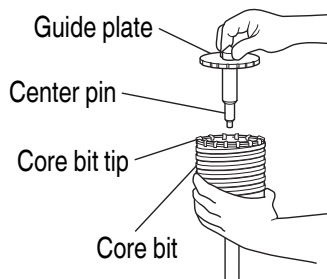

Fig. 35

2. How to bore (**Fig. 36**)

- (1) Install the battery.
- (2) A spring is installed in the center pin. Push it lightly to the wall or the floor straight. Connect the core bit tip flush to the surface and start operating.
- (3) When boring about 5 mm in depth the position of the hole will be established. Bore after that removing the center pin and the guide plate from core bit.

WARNING

- **When removing the center pin and the guide plate, turn OFF the switch and disconnect the battery.**
- **Application of excessive force will not only expedite the work, but will deteriorate the tip edge of the drill bit, resulting in reduced service life of the rotary hammer.**

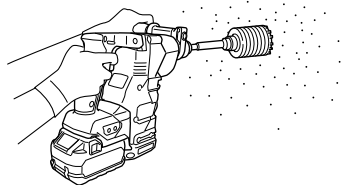

Fig. 36

3. Dismounting (**Fig. 37**)

Remove the core bit shank from the rotary hammer and strike the head of the core bit shank strongly two or three times with a hammer holding the core bit, then the thread becomes loose and the core bit can be removed.

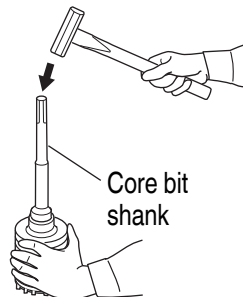

Fig. 37

OPERATIONAL CAUTIONS

Resting the unit after continuous work

- (1) The power tool is equipped with a temperature protection circuit to protect the motor. Continuous work may cause the temperature of the unit to rise, activating the temperature protection circuit and automatically stopping operation. If this happens, allow the power tool to cool before resuming use.
- (2) After use for continuous works, rest the unit for 15 minutes or so when replacing the battery. The temperature of the motor, switch, etc., will rise if the work is started again immediately after battery replacement, eventually resulting in burnout.

SELECT OPERATION MODE

Pressing the changeover switch allows the selection of rotation speed and the auto stop function.

- Rotation speed (Low mode/Normal mode) (**Fig. 38**)
Select either Low mode or Normal mode and operate the tool in the selected speed.
- Auto stop mode (on/off) (**Fig. 39**)
This product is equipped with an auto stop function to support continuous drilling work. The function features a memory mode for storing the work time for drilling from switch ON to switch OFF, and an auto stop mode that automatically stops the motor from the second drilling onward should the work exceed the stored work time while the switch is ON.

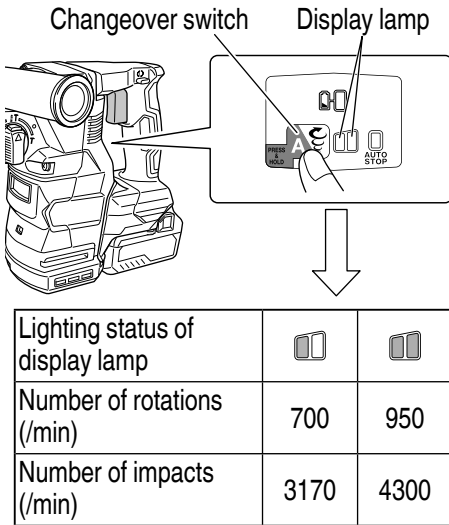

Fig. 38

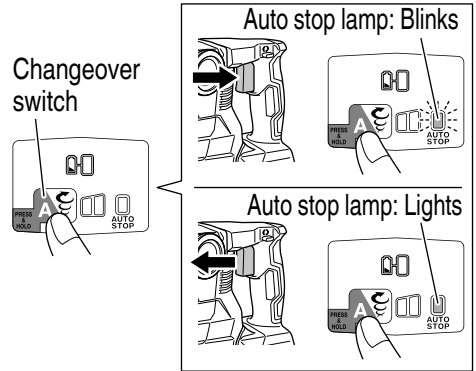

Fig. 39

AUTO STOP FUNCTION

In selection mode, pressing the changeover switch for longer than two seconds will move to memory mode. (**Fig. 39**)

(At the same time the auto stop lamp will blink.)

Conduct drilling when the auto stop lamp is flashing. The time between switching ON and switching OFF is stored by the tool.

(At the same time, the auto stop lamp will light up.)

Conduct drilling when the auto stop lamp is flashing. Continuous drilling is possible as the memory storage time will be recorded by the tool until the auto stop function's auto stop mode is cancelled. The auto stop function is cancelled by pressing the changeover switch once again for over two seconds.

(At the same time, the auto stop lamp will switch off.)

CAUTION

- Switch ON the tool once you place the tip of the tool on the work material.
- The rotation speed and the level at which the switch is pulled during drilling is not stored to memory.
- Fully carry out drilling in one go during auto stop mode.
- The motor will stop even if you switch OFF within the memory storage time.
- When you switch OFF within the memory storage time, the count will be reset. If you rework a task in which a hole has been partially drilled, the memory storage time will be fully recounted.
- The auto stop function will remain active until canceled.

REACTIVE FORCE CONTROL

This product is equipped with a Reactive Force Control (RFC) feature that reduces jerking of the tool body.

If the tool bit is suddenly overburdened, any jerking of the tool body is reduced by activation of the slip clutch or by stopping of the motor by the sensor built into the tool body. If the motor is stopped because of overburdening detection by the controller, the display lamp will blink while the switch is pulled. In addition, the lamp will continue blinking for approximately three seconds after the switch is released. The motor will remain stopped while the lamp is blinking. (Fig. 40)

Because the RFC feature may not activate or its performance may be insufficient depending on the working environment and conditions, be careful not to suddenly overburden the tool bit while operating.

- Possible causes of sudden overburdening
 - ① Tool bit biting into material
 - ② Impact against nails, metal or other hard objects
 - ③ Tasks involving prying or any excess application of pressure, etc.

Also, other causes include any combination of the aforementioned.

- When the reactive force control (RFC) is triggered
When the RFC is triggered and the motor stops, turn off the tool's switch and remove the cause of the overburdening before continuing operation.

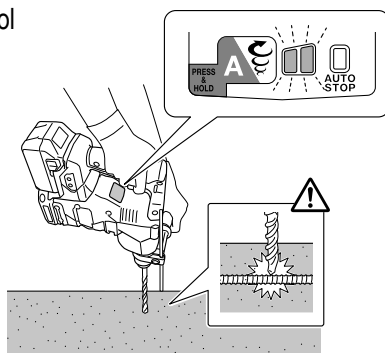

Fig. 40

ABOUT THE PROTECTION FUNCTION

This tool has a built-in protection circuit for preventing damage to the unit in the event of an abnormality. Depending on the following, the display lamp will flash, and the unit will cease to operate. Verify the problem indicated by the flashing and take the necessary steps to correct the problem.

When pressing the changeover switch, do so when the switch is not being pulled.

Changeover switch

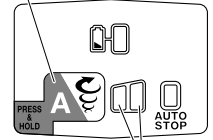

Display lamp

Fig. 41

Table 5

Display lamp flashing	Cause	Solution
	Operation has ceased because the internal temperature has exceeded the temperature limit. (High temperature protection function)	Allow the unit to cool for 15 to 30 minutes. When the temperature goes down and the display lamp blinking stops, pull the switch trigger to recover operation.
	Sudden overburdening of the tool bit has activated the RFC, stopping further operation of the tool. RFC (See page 61 "REACTIVE FORCE CONTROL")	Release the switch trigger and leave it until the display lamp blinking stops. Pull the switch trigger again to recover operation. Before continuing operation, remove the cause of the overburden.

NOTE

Despite taking steps to correct a problem, the display lamp may continue to blink. Should this be the case, the unit may require repair. If so, please contact the outlet from which this product was purchased for repairs.

LUBRICATION

Low viscosity grease is applied to this rotary hammer so that it can be used for a long period without replacing the grease. Please contact the nearest service center for grease replacement when any grease is leaking from loosened screw.

Further use of the rotary hammer despite the grease shortage causes damage to reduce the service life.

CAUTION

A specific grease is used with this machine, therefore, the normal performance of the machine may be badly affected by use of different grease. Please be sure to let one of our service centers to undertake replacement of the grease.

MAINTENANCE AND INSPECTION

CAUTION

Be sure to turned off the switch and remove the battery before maintenance and inspection.

1. Inspecting the tool
Since use of as dull tool will degrade efficiency and cause possible motor malfunction, sharpen or replace the tool as soon as abrasion is noted.
2. Inspecting the mounting screws
Regularly inspect all mounting screws and ensure that they are properly tightened. Should any of the screws be loose, retighten them immediately. Failure to do so could result in serious hazard.
3. Maintenance of the motor
The motor unit winding is the very “heart” of the power tool. Exercise due care to ensure the winding does not become damaged and/or wet with oil or water.
4. Inspection of terminals (tool and battery)
Check to make sure that swarf and dust have not collected on the terminals.
On occasion check prior, during and after operation.

CAUTION

**Remove any swarf or dust which may have collected on the terminals.
Failure to do so may result in malfunction.**

5. Cleaning on the outside
When the power tool is stained, wipe with a soft dry cloth or a cloth moistened with soapy water. Do not use chloric solvents, gasoline or paint thinner, for they melt plastics.
6. Cleaning the Battery Mount and Battery

WARNING

When using an air gun for cleaning, make sure to wear safety glasses and a dust mask. Doing so will protect your eyes and prevent the breathing in of emitted concrete dust.

After drilling concrete, concrete dust may accumulate on the parts depicted in the diagram. In such cases, use the tool after cleaning off the accumulated dust with a dry cloth or air gun. (Fig. 42, 43 on page 64)

English

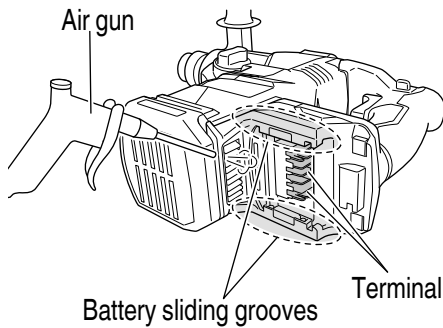

Fig. 42

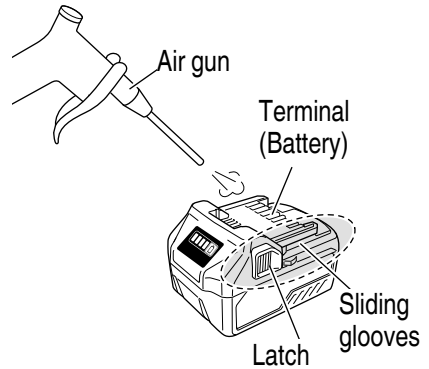

Fig. 43

NOTE

After cleaning, make sure that the battery can be smoothly installed to and removed from the main body.

NOTE

Using the tool with accumulated concrete dust may cause accidents such as the battery falling off during use.
Also, it may result in malfunction or contact failure between the battery and the terminals.

7. Storage

Store the power tool in a place in which the temperature is less than 40°C and out of reach of children.

NOTE

Storing lithium-ion batteries

Make sure the lithium-ion batteries have been fully charged before storing them. Prolonged storage (3 months or more) of batteries with a low charge may result in performance deterioration, significantly reducing battery usage time or rendering the batteries incapable of holding a charge.

However, significantly reduced battery usage time may be recovered by repeatedly charging and using the batteries two to five times.

If the battery usage time is extremely short despite repeated charging and use, consider the batteries dead and purchase new batteries.

CAUTION

In the operation and maintenance of power tools, the safety regulations and standards prescribed in each country must be observed.

Important notice on the batteries for the HiKOKI cordless power tools

Please always use one of our designated genuine batteries. We cannot guarantee the safety and performance of our cordless power tool when used with batteries other than these designated by us, or when the battery is disassembled and modified (such as disassembly and replacement of cells or other internal parts).

TROUBLESHOOTING

Use the inspections in the table below if the tool does not operate normally. If this does not remedy the problem, consult your dealer or the HiKOKI Authorized Service Center.

1. Power tool

Symptom	Possible cause	Remedy
Tool doesn't run	No remaining battery power	Charge the battery.
	Battery isn't securely attached.	Push in the battery until a click is heard.
	Concrete dust has accumulated on the terminals of the battery installation compartment as well as on the battery sliding grooves.	Clean off the accumulated concrete dust with an air gun or a dry cloth.
Tool suddenly stopped	Tool was overburdened	Get rid of the problem causing the overburden.
	Reactive force control was activated	
	The battery is overheated.	Let the battery cool down.
Tool bits -can't be attached -fall off	The shape of the attachment portion doesn't match	For the SDS-plus shank type, use a bit with a diameter that is within the designated range.
Holes can't be smoothly drilled.	The drill is worn	Replace with a new drill.
	The drill is rotating in reverse	Switch to forward rotation.
Screw head slips or comes loose.	Bit number doesn't match with the screw size	Install a suitable bit.
	The bit is worn	Replace with a new bit.
Battery cannot be installed	Attempting to install a battery other than that specified for the tool.	Please install batteries that are multi volt or BSL18xx series.

English

2. Charger

Symptom	Possible cause	Remedy
The charge indicator lamp rapidly flickers purple, and battery charging doesn't begin.	The battery is not inserted all the way.	Insert the battery firmly.
	There is foreign matter in the battery terminal or where the battery is attached.	Remove the foreign matter.
The charge indicator lamp blinks red, and battery charging doesn't begin.	The battery is not inserted all the way.	Insert the battery firmly.
	The battery is overheated.	If left alone, the battery will automatically begin charging if its temperature decreases, but this may reduce battery life. It is recommended that the battery be cooled in a well-ventilated location away from direct sunlight before charging it.
Battery usage time is short even though the battery is fully charged.	The battery's life is depleted.	Replace the battery with a new one.
The battery takes a long time to charge.	The temperature of the battery, the charger, or the surrounding environment is extremely low.	Charge the battery indoors or in another warmer environment.
	The charger's vents are blocked, causing its internal components to overheat.	Avoid blocking the vents.
	The cooling fan is not running.	Contact a HiKOKI Authorized Service Center for repairs.
The USB power lamp has switched off and the USB device has stopped charging.	The battery's capacity has become low.	Replace the battery with one that has capacity remaining.
		Plug the charger's power plug into an electric socket.
USB power lamp does not switch off even though the USB device has finished charging.	The USB power lamp lights up green to indicate that USB charging is possible.	This is not a malfunction.

Symptom	Possible cause	Remedy
It is unclear what the charging status of a USB device is, or whether its charging is complete.	The USB power lamp does not switch off even when charging is complete.	Examine the USB device that is charging to confirm its charging status.
Charging of a USB device pauses midway.	The charger was plugged into an electrical socket while the USB device was being charged using the battery as the power source.	This is not a malfunction. The charger pauses USB charging for about 5 seconds when it is differentiating between power sources.
	A battery was inserted into the charger while the USB device was being charged using a power socket as the power source.	
Charging of the USB device pauses midway when the battery and the USB device are being charged at the same time.	The battery has become fully charged.	This is not a malfunction. The charger pauses USB charging for about 5 seconds while it checks whether the battery has successfully completed charging.
Charging of the USB device doesn't start when the battery and the USB device are being charged at the same time.	The remaining battery capacity is extremely low.	This is not a malfunction. When the battery capacity reaches a certain level, USB charging automatically begins.

SELECTING ACCESSORIES

Select accessories that are suited to a specific task.
For details contact HiKOKI Authorized Service Center.

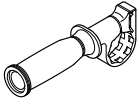

Part Number: 335273
Side handle

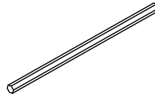

Part Number: 303709
Depth gauge

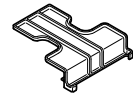

Part Number: 329897
Battery cover



36 V (Li-ion)
Battery

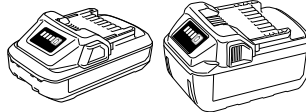

18 V (Li-ion)
Battery

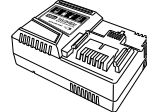

UC18YSL3
(14.4 V-18 V)
Charger

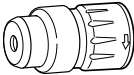

Part Number: 375010
Drill bit holder

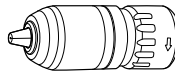

Part Number: 377959
Drill chuck holder

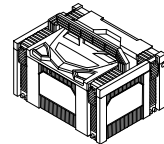

Part Number: 337108
Case (Stackable)

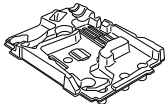

Part Number: 379786
Inner tray

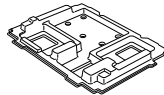

Part Number: 379787
Inner tray

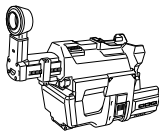

Part Number:
379135 (DH1826DA)
379139 (DH1826DC)
Dust extractor system for
Rotary hammer

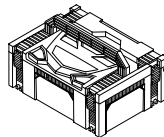

Part Number: 336471
Case (Stackable)

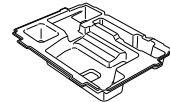

Part Number: 379788
Inner tray

Part Number : 379136 (DH1826DA)
Part Number : 379140 (DH1826DC)

Tool and Adapter

For details contact HiKOKI Authorized Service Center.

NOTE

Specifications are subject to change without any obligation on the part of the HiKOKI.

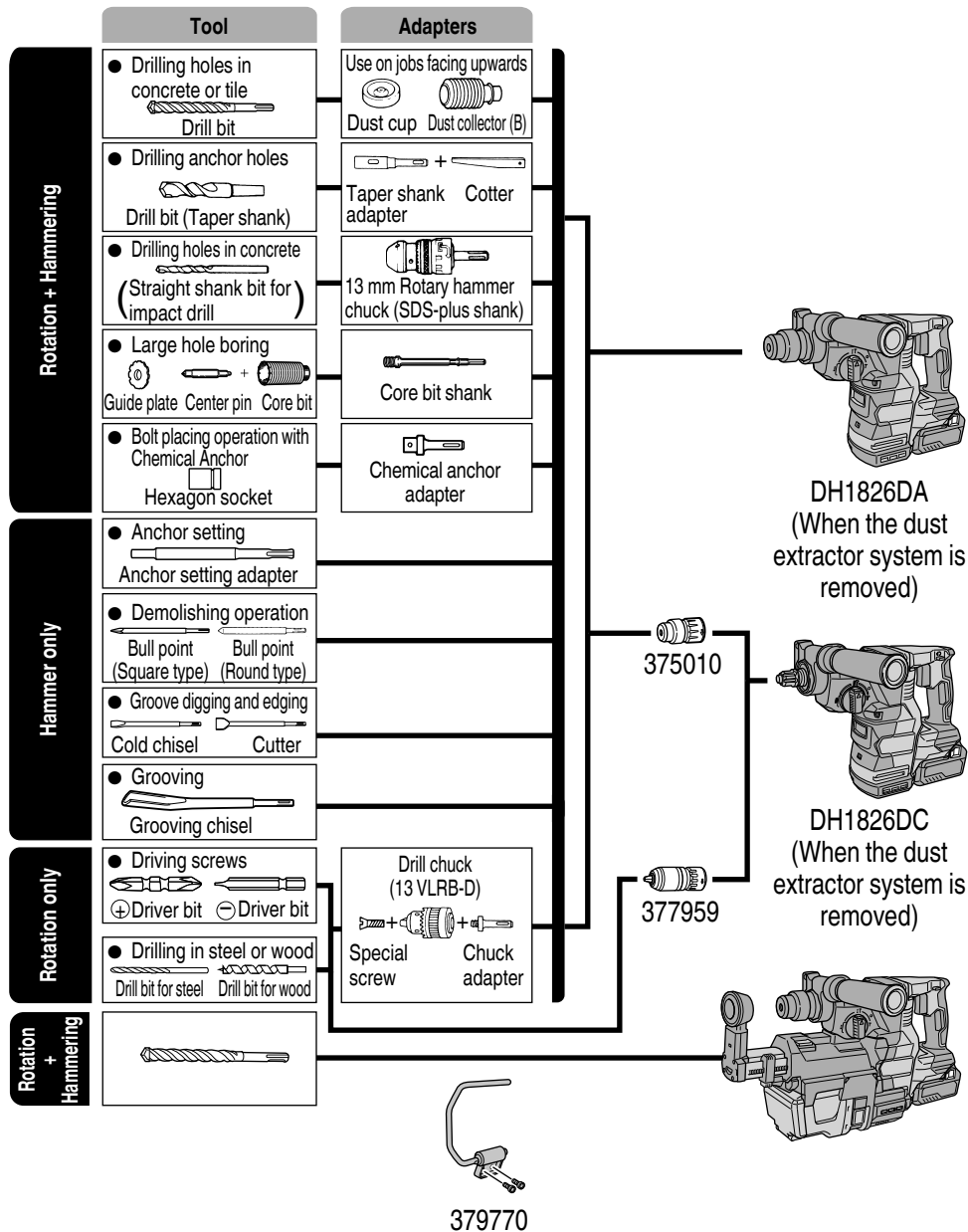

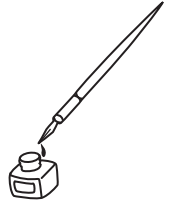

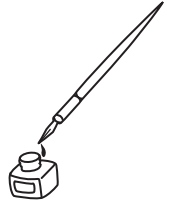

服务中心
高壹工机商业(上海)有限公司
上海市闵行区浦江工业园区三鲁路3585号7幢3楼

制造商
福建高壹工机有限公司
福建省福州市福兴投资区湖塘路

Koki Holdings Co., Ltd.

207

编号: C99748021 F
发行日期: 2022年 7月
中国印刷