

## G3610DVE • G3613DVE • G3615DVE

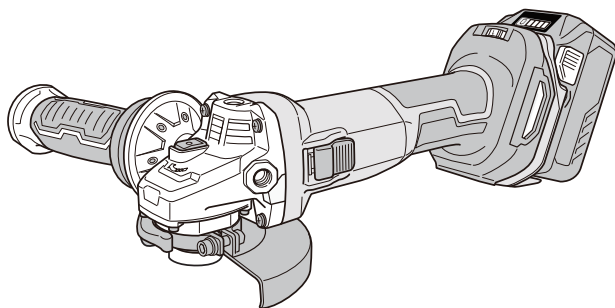

G3610DVE



en Handling instructions

zh 使用說明書

1

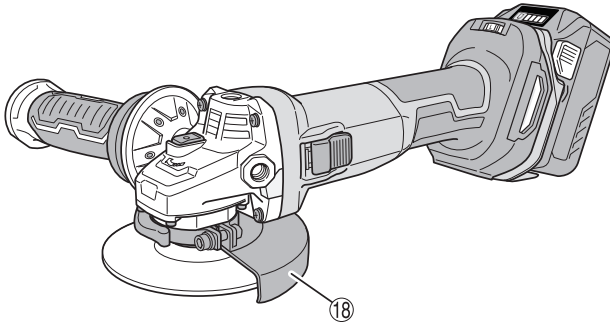

G3610DVE

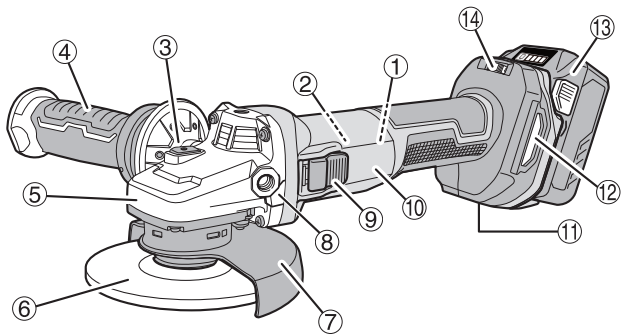
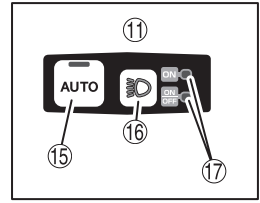

G3613DVE, G3615DVE

2

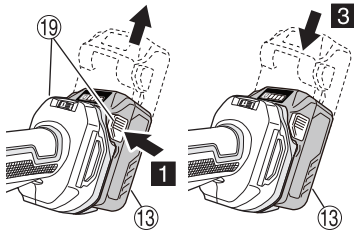

3

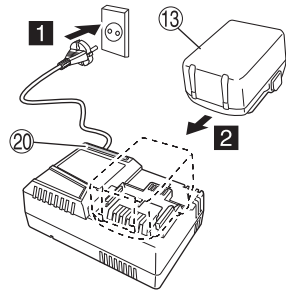

4

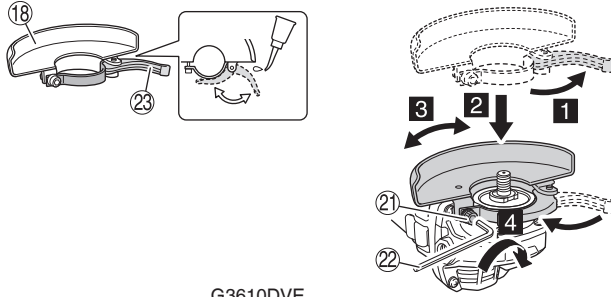

G3610DVE

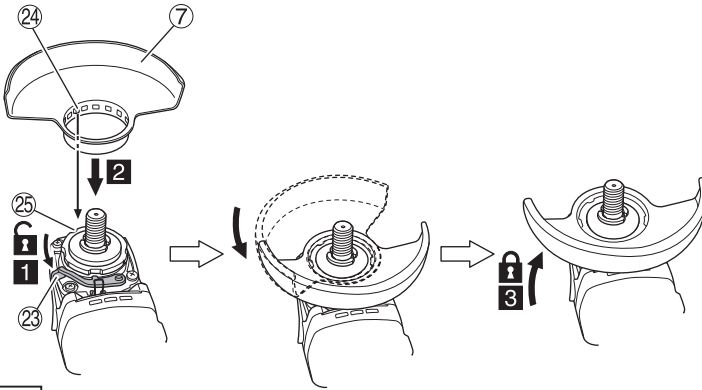

G3613DVE, G3615DVE



5

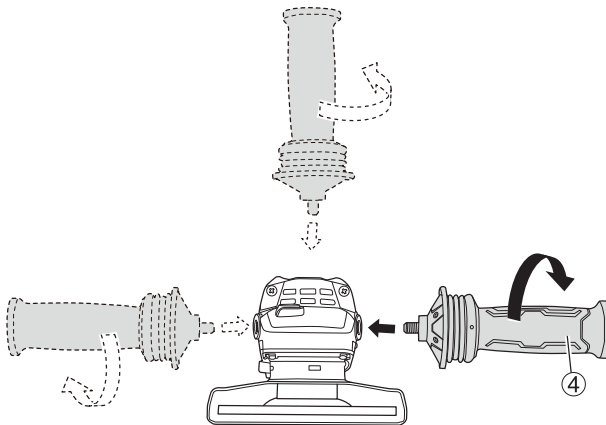

6

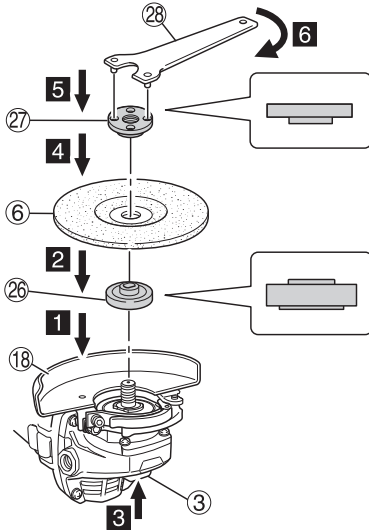

G3610DVE

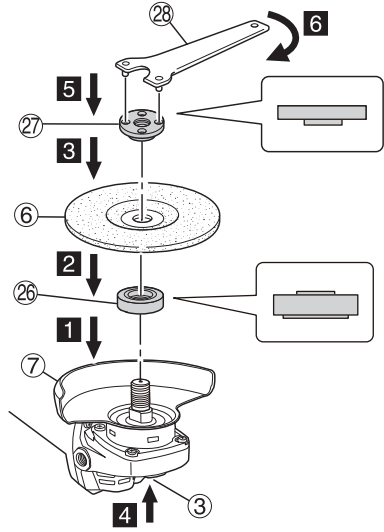

G3613DVE, G3615DVE



7

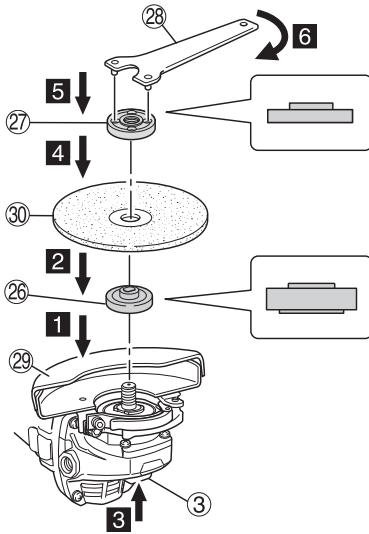

G3610DVE

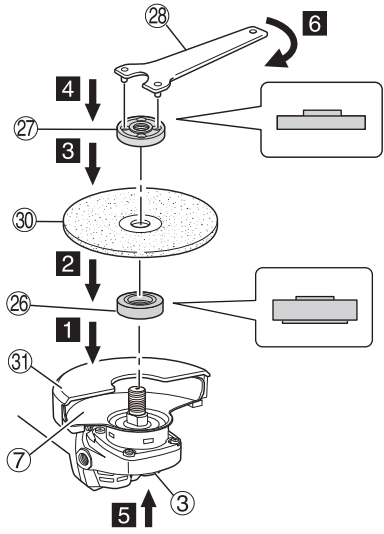

G3613DVE, G3615DVE



8

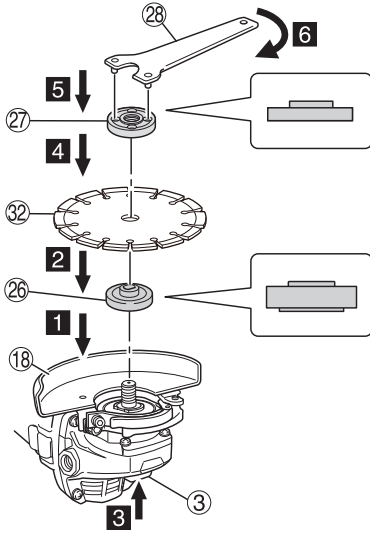

G3610DVE

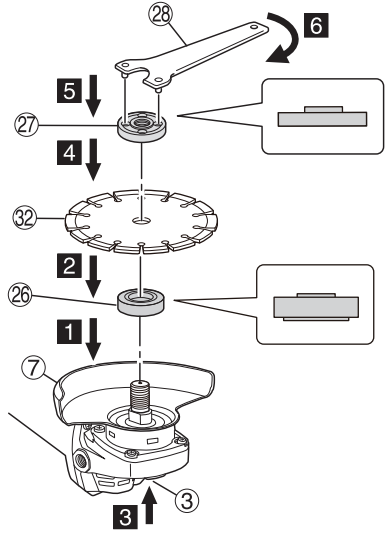

G3613DVE, G3615DVE



9

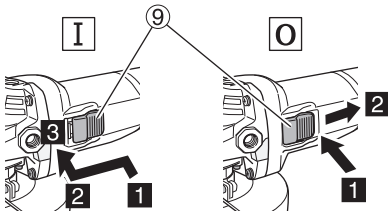

10

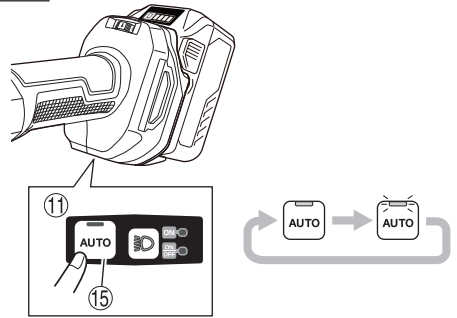

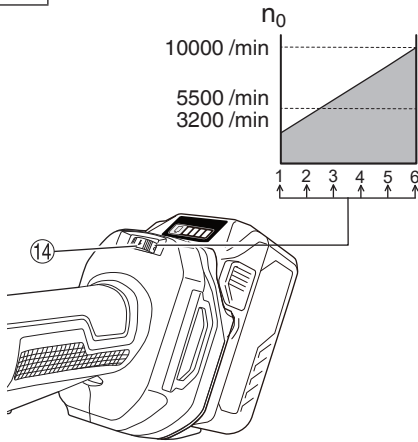
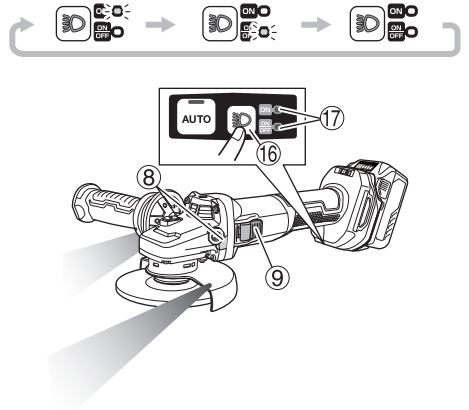
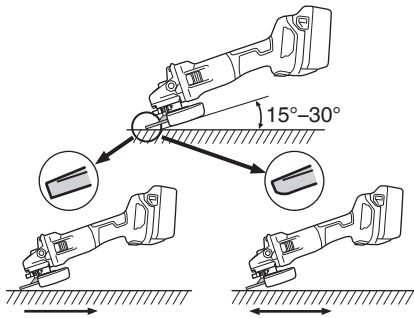
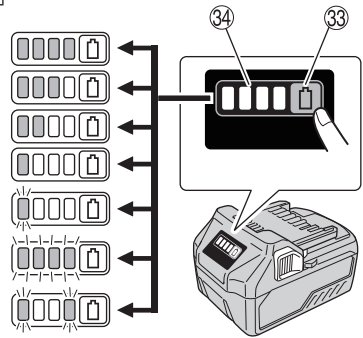
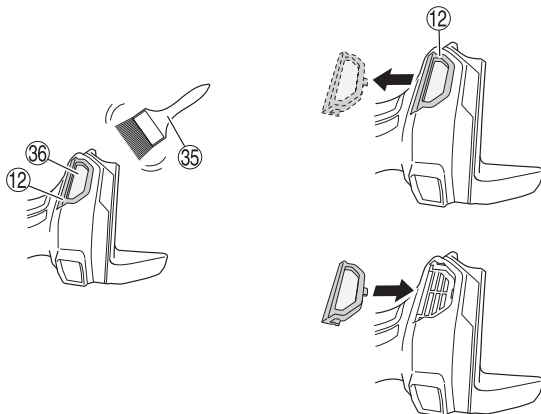
**11****12****13****14****15**

## GENERAL POWER TOOL SAFETY WARNINGS

### ⚠ WARNING

**Read all safety warnings and all instructions.**

*Failure to follow the warnings and instructions may result in electric shock, fire and/or serious injury.*

**Save all warnings and instructions for future reference.**

*The term "power tool" in the warnings refers to your mains-operated (corded) power tool or battery-operated (cordless) power tool.*

#### 1) Work area safety

- a) **Keep work area clean and well lit.**  
*Cluttered or dark areas invite accidents.*
- b) **Do not operate power tools in explosive atmospheres, such as in the presence of flammable liquids, gases or dust.**  
*Power tools create sparks which may ignite the dust or fumes.*
- c) **Keep children and bystanders away while operating a power tool.**  
*Distractions can cause you to lose control.*

#### 2) Electrical safety

- a) **Power tool plugs must match the outlet. Never modify the plug in any way. Do not use any adapter plugs with earthed (grounded) power tools.**  
*Unmodified plugs and matching outlets will reduce risk of electric shock.*
- b) **Avoid body contact with earthed or grounded surfaces, such as pipes, radiators, ranges and refrigerators.**  
*There is an increased risk of electric shock if your body is earthed or grounded.*
- c) **Do not expose power tools to rain or wet conditions.**  
*Water entering a power tool will increase the risk of electric shock.*
- d) **Do not abuse the cord. Never use the cord for carrying, pulling or unplugging the power tool. Keep cord away from heat, oil, sharp edges or moving parts.**  
*Damaged or entangled cords increase the risk of electric shock.*
- e) **When operating a power tool outdoors, use an extension cord suitable for outdoor use.**  
*Use of a cord suitable for outdoor use reduces the risk of electric shock.*
- f) **If operating a power tool in a damp location is unavoidable, use a residual current device (RCD) protected supply.**  
*Use of an RCD reduces the risk of electric shock.*

#### 3) Personal safety

- a) **Stay alert, watch what you are doing and use common sense when operating a power tool. Do not use a power tool while you are tired or under the influence of drugs, alcohol or medication.**  
*A moment of inattention while operating power tools may result in serious personal injury.*
- b) **Use personal protective equipment. Always wear eye protection.**  
*Protective equipment such as dust mask, non-skid safety shoes, hard hat, or hearing protection used for appropriate conditions will reduce personal injuries.*

- c) **Prevent unintentional starting. Ensure the switch is in the off position before connecting to power source and/or battery pack, picking up or carrying the tool.**

*Carrying power tools with your finger on the switch or energising power tools that have the switch on invites accidents.*

- d) **Remove any adjusting key or wrench before turning the power tool on.**

*A wrench or a key left attached to a rotating part of the power tool may result in personal injury.*

- e) **Do not overreach. Keep proper footing and balance at all times.**

*This enables better control of the power tool in unexpected situations.*

- f) **Dress properly. Do not wear loose clothing or jewellery. Keep your hair, clothing and gloves away from moving parts.**

*Loose clothes, jewellery or long hair can be caught in moving parts.*

- g) **If devices are provided for the connection of dust extraction and collection facilities, ensure these are connected and properly used.**

*Use of dust collection can reduce dust-related hazards.*

#### 4) Power tool use and care

- a) **Do not force the power tool. Use the correct power tool for your application.**

*The correct power tool will do the job better and safer at the rate for which it was designed.*

- b) **Do not use the power tool if the switch does not turn it on and off.**

*Any power tool that cannot be controlled with the switch is dangerous and must be repaired.*

- c) **Disconnect the plug from the power source and/or the battery pack from the power tool before making any adjustments, changing accessories, or storing power tools.**

*Such preventive safety measures reduce the risk of starting the power tool accidentally.*

- d) **Store idle power tools out of the reach of children and do not allow persons unfamiliar with the power tool or these instructions to operate the power tool.**

*Power tools are dangerous in the hands of untrained users.*

- e) **Maintain power tools. Check for misalignment or binding of moving parts, breakage of parts and any other condition that may affect the power tool's operation. If damaged, have the power tool repaired before use.**

*Many accidents are caused by poorly maintained power tools.*

- f) **Keep cutting tools sharp and clean.**

*Properly maintained cutting tools with sharp cutting edges are less likely to bind and are easier to control.*

- g) **Use the power tool, accessories and tool bits etc. in accordance with these instructions, taking into account the working conditions and the work to be performed.**

*Use of the power tool for operations different from those intended could result in a hazardous situation.*

#### 5) Battery tool use and care

- a) **Recharge only with the charger specified by the manufacturer.**

*A charger that is suitable for one type of battery pack may create a risk of fire when used with another battery pack.*

# English

- b) Use power tools only with specifically designated battery packs.  
*Use of any other battery packs may create a risk of injury and fire.*
- c) When battery pack is not in use, keep it away from other metal objects, like paper clips, coins, keys, nails, screws or other small metal objects, that can make a connection from one terminal to another.  
*Shorting the battery terminals together may cause burns or a fire.*
- d) Under abusive conditions, liquid may be ejected from the battery; avoid contact. If contact accidentally occurs, flush with water. If liquid contacts eyes, additionally seek medical help.  
*Liquid ejected from the battery may cause irritation or burns.*
- 6) Service
- a) Have your power tool serviced by a qualified repair person using only identical replacement parts.  
*This will ensure that the safety of the power tool is maintained.*

## PRECAUTION

Keep children and infirm persons away.

When not in use, tools should be stored out of reach of children and infirm persons.

## SAFETY WARNINGS COMMON FOR GRINDING OR ABRASIVE CUTTING-OFF OPERATIONS

- a) This power tool is intended to function as a grinder or cut-off tool. Read all safety warnings, instructions, illustrations and specifications provided with this power tool.  
*Failure to follow all instructions listed below may result in electric shock, fire and/or serious injury.*
- b) Operations such as sanding, wire brushing or polishing are not recommended to be performed with this power tool.  
*Operations for which the power tool was not designed may create a hazard and cause personal injury.*
- c) Do not use accessories which are not specifically designed and recommended by the tool manufacturer.  
*Just because the accessory can be attached to your power tool, it does not assure safe operation.*
- d) The rated speed of the accessory must be at least equal to the maximum speed marked on the power tool.  
*Accessories running faster than their rated speed can break and fly apart.*
- e) The outside diameter and the thickness of your accessory must be within the capacity rating of your power tool.  
*Incorrectly sized accessories cannot be adequately guarded or controlled.*
- f) Threaded mounting of accessories must match the grinder spindle thread. For accessories mounted by flanges, the arbour hole of the accessory must fit the locating diameter of the flange.  
*Accessories that do not match the mounting hardware of the power tool will run out of balance, vibrate excessively and may cause loss of control.*
- g) Do not use a damaged accessory. Before each use inspect the accessory such as abrasive wheels for chips and cracks, backing pad for cracks, tear or excess wear, wire brush for loose or cracked wires. If power tool or accessory is dropped, inspect for damage or install an undamaged accessory. After inspecting and installing an accessory, position yourself and bystanders away from the plane of the rotating accessory and run the power tool at maximum no-load speed for one minute.  
*Damaged accessories will normally break apart during this test time.*
- h) Wear personal protective equipment. Depending on application, use face shield, safety goggles or safety glasses. As appropriate, wear dust mask, hearing protectors, gloves and workshop apron capable of stopping small abrasive or workpiece fragments.  
*The eye protection must be capable of stopping flying debris generated by various operations. The dust mask or respirator must be capable of filtering particles generated by your operation. Prolonged exposure to high intensity noise may cause hearing loss.*
- i) Keep bystanders a safe distance away from work area. Anyone entering the work area must wear personal protective equipment.  
*Fragments of workpiece or of a broken accessory may fly away and cause injury beyond immediate area of operation.*
- j) Hold the power tool by insulated gripping surfaces only, when performing an operation where the cutting tool may contact hidden wiring.  
*Contact with a "live" wire will also make exposed metal parts of the power tool "live" and could give the operator an electric shock.*
- k) Position the cord clear of the spinning accessory.  
*If you lose control, the cord may be cut or snagged and your hand or arm may be pulled into the spinning accessory.*
- l) Never lay the power tool down until the accessory has come to a complete stop.  
*The spinning accessory may grab the surface and pull the power tool out of your control.*
- m) Do not run the power tool while carrying it at your side.  
*Accidental contact with the spinning accessory could snag your clothing, pulling the accessory into your body.*
- n) Regularly clean the power tool's air vents.  
*The motor's fan will draw the dust inside the housing and excessive accumulation of powdered metal may cause electrical hazards.*
- o) Do not operate the power tool near flammable materials.  
*Sparks could ignite these materials.*
- p) Do not use accessories that require liquid coolants.  
*Using water or other liquid coolants may result in electrocution or shock.*

## KICKBACK AND RELATED WARNINGS

Kickback is a sudden reaction to a pinched or snagged rotating wheel, backing pad, brush or any other accessory. Pinching or snagging causes rapid stalling of the rotating accessory which in turn causes the uncontrolled power tool to be forced in the direction opposite of the accessory's rotation at the point of the binding.  
*For example, if an abrasive wheel is snagged or pinched by the workpiece, the edge of the wheel that is entering into the pinch point can dig into the surface of the material causing the wheel to climb out or kick out. The wheel may either jump*



toward or away from the operator, depending on direction of the wheel's movement at the point of pinching.

Abrasive wheels may also break under these conditions.

Kickback is the result of power tool misuse and/or incorrect operating procedures or conditions and can be avoided by taking proper precautions as given below.

- a) **Maintain a firm grip on the power tool and position your body and arm to allow you to resist kickback forces. Always use auxiliary handle, if provided, for maximum control over kickback or torque reaction during start-up.**

*The operator can control torque reactions or kickback forces, if proper precautions are taken.*

- b) **Never place your hand near the rotating accessory. Accessory may kickback over your hand.**

- c) **Do not position your body in the area where power tool will move if kickback occurs.**

*Kickback will propel the tool in direction opposite to the wheel's movement at the point of snagging.*

- d) **Use special care when working corners, sharp edges etc. Avoid bouncing and snagging the accessory.**

*Corners, sharp edges or bouncing have a tendency to snag the rotating accessory and cause loss of control or kickback.*

- e) **Do not attach a saw chain woodcarving blade or toothed saw blade.**

*Such blades create frequent kickback and loss of control.*

## SAFETY WARNINGS SPECIFIC FOR GRINDING AND ABRASIVE CUTTING-OFF OPERATIONS

- a) **Use only wheel types that are recommended for your power tool and the specific guard designed for the selected wheel.**

*Wheels for which the power tool was not designed cannot be adequately guarded and are unsafe.*

- b) **The grinding surface of centre depressed wheels must be mounted below the plane of the guard lip.**

*An improperly mounted wheel that projects through the plane of the guard lip cannot be adequately protected.*

- c) **The guard must be securely attached to the power tool and positioned for maximum safety, so the least amount of wheel is exposed towards the operator.**

*The guard helps to protect the operator from broken wheel fragments, accidental contact with wheel and sparks that could ignite clothing.*

- d) **Wheels must be used only for recommended applications. For example: do not grind with the side of cut-off wheel.**

*Abrasive cut-off wheels are intended for peripheral grinding, side forces applied to these wheels may cause them to shatter.*

- e) **Always use undamaged wheel flanges that are of correct size and shape for your selected wheel.**

*Proper wheel flanges support the wheel thus reducing the possibility of wheel breakage. Flanges for cut-off wheels may be different from grinding wheel flanges.*

- f) **Do not use worn down wheels from larger power tools.**

*Wheel intended for larger power tool is not suitable for the higher speed of a smaller tool and may burst.*

## ADDITIONAL SAFETY WARNINGS SPECIFIC FOR ABRASIVE CUTTING-OFF OPERATIONS

- a) **Do not "jam" the cut-off wheel or apply excessive pressure. Do not attempt to make an excessive depth of cut.**

*Overstressing the wheel increases the loading and susceptibility to twisting or binding of the wheel in the cut and the possibility of kickback or wheel breakage.*

- b) **Do not position your body in line with and behind the rotating wheel.**

*When the wheel, at the point of operation, is moving away from your body, the possible kickback may propel the spinning wheel and the power tool directly at you.*

- c) **When wheel is binding or when interrupting a cut for any reason, switch off the power tool and hold the power tool motionless until the wheel comes to a complete stop. Never attempt to remove the cut-off wheel from the cut while the wheel is in motion otherwise kickback may occur.**

*Investigate and take corrective action to eliminate the cause of wheel binding.*

- d) **Do not restart the cutting operation in the workpiece. Let the wheel reach full speed and carefully re-enter the cut.**

*The wheel may bind, walk up or kickback if the power tool is restarted in the workpiece.*

- e) **Support panels or any oversized workpiece to minimize the risk of wheel pinching and kickback.**

*Large workpieces tend to sag under their own weight. Supports must be placed under the workpiece near the line of cut and near the edge of the workpiece on both sides of the wheel.*

- f) **Use extra caution when making a "pocket cut" into existing walls or other blind areas.**

*The protruding wheel may cut gas or water pipes, electrical wiring or objects that can cause kickback.*

## GENERAL SAFETY INSTRUCTIONS FOR CORDLESS DISC GRINDERS

- Check that speed marked on the wheel is equal to or greater than the rated speed of the grinder;
- Ensure that the wheel dimensions are compatible with the grinder;
- Abrasive wheels shall be stored and handled with care in accordance with manufacturer's instructions;
- Inspect the grinding wheel before use, do not use chipped, cracked or otherwise defective products;
- Ensure that mounted wheels and points are fitted in accordance with the manufacturer's instructions;
- Ensure that blotters are used when they are provided with the bonded abrasive product and when they are required;
- Ensure that the abrasive product is correctly mounted and tightened before use and run the tool at no-load for 30 seconds in a safe position, stop immediately if there is considerable vibration or if other defects are detected. If this condition occurs, check the machine to determine the cause;
- If a guard is equipped with the tool never use the tool without such a guard;
- <G3610DVE> When using an abrasive cutting wheel, be sure to remove the standard accessory wheel guard and attach the wheel guard with side guard (sold separately) (Fig. 7);
- <G3613DVE, G3615DVE> When using an abrasive cutting wheel, be sure to attach the guard clip for cutting wheel (sold separately) over the standard-accessory wheel guard. (Fig. 7);

## English

- Do not use separate reducing bushings or adapters to adapt large hole abrasive wheels;
- For tools intended to be fitted with threaded hole wheel, ensure that the thread in the wheel is long enough to accept the spindle length;
- Check that the work piece is properly supported;
- Do not use cutting off wheel for side grinding;
- Ensure that sparks resulting from use do not create a hazard e.g. do not hit persons, or ignite flammable substances;
- Ensure that ventilation openings are kept clear when working in dusty conditions, if it should become necessary to clear dust, first disconnect the tool from the mains supply (use non metallic objects) and avoid damaging internal parts;
- Always use eye and ear protection. Other personal protective equipment such as dust mask, gloves, helmet and apron should be worn;
- Pay attention to the wheel that continues to rotate after the tool is switched off.

### **WARNING**

- When using a cutting-off wheel, be sure to attach the cutting-off guard.
- When using a grinding wheel, be sure to attach the grinding wheel guard.

### **ADDITIONAL SAFETY WARNINGS**

1. Ensure that the depressed center wheel to be utilized is the correct type and free of cracks or surface defects. Also ensure that the depressed center wheel is properly mounted and the wheel nut is securely tightened.
2. Confirm that the push button is disengaged by pushing push button two or three times before switching the power tool on.
3. To prolong the life of the machine and ensure a first class finish, it is important that the machine should not be overloaded by applying too much pressure. In most applications, the weight of the machine alone is sufficient for effective grinding. Too much pressure will result in reduced rotational speed, inferior surface finish, and overloading which could reduce the life of the machine.
4. The wheel continues to rotate after the tool is switched off.  
After switching off the machine, do not put it down until the depressed center wheel has come to a complete stop. Apart from avoiding serious accidents, this precaution will reduce the amount of dust and swarf sucked into the machine.
5. When the machine is not use, the power source should be disconnected.
6. Be sure to switch OFF and pull out the battery to avoid a serious accident before the depressed center wheel is assembling and disassembling.
7. Be careful of brake kickback.  
This cordless disc grinder features an electric brake that functions when the switch is released. As there is some kickback when the brake functions, be sure to hold the main body securely.
8. Do not use the product if the tool or the battery terminals (battery mount) are deformed.  
Installing the battery could cause a short circuit that could result in smoke emission or ignition.
9. Keep the tool's terminals (battery mount) free of swarf and dust.
  - Prior to use, make sure that swarf and dust have not collected in the area of the terminals.
  - During use, try to avoid swarf or dust on the tool from falling on the battery.
  - When suspending operation or after use, do not leave the tool in an area where it may be exposed to falling swarf or dust.

Doing so could cause a short circuit that could result in smoke emission or ignition.

### **PRECAUTIONS FOR BATTERY AND CHARGER**

1. Always charge the battery at an ambient temperature of -10–40°C. A temperature of less than -10°C will result in over charging which is dangerous. The battery cannot be charged at a temperature greater than 40°C. The most suitable temperature for charging is that of 20–25°C.
2. Do not use the charger continuously.  
When one charging is completed, leave the charger for about 15 minutes before the next charging of battery.
3. Do not allow foreign matter to enter the hole for connecting the rechargeable battery.
4. Never disassemble the rechargeable battery or charger.
5. Never short-circuit the rechargeable battery.  
Short-circuiting the battery will cause a great electric current and overheat. It results in burn or damage to the battery.
6. Do not dispose of the battery in fire.  
If the battery is burnt, it may explode.
7. Using an exhausted battery will damage the charger.
8. Bring the battery to the shop from which it was purchased as soon as the post-charging battery life becomes too short for practical use. Do not dispose of the exhausted battery.
9. Do not insert objects into the air ventilation slots of the charger.  
Inserting metal objects or flammable into the charger air ventilation slots will result in an electrical shock hazard or damage to the charger.

### **CAUTION ON LITHIUM-ION BATTERY**

To extend the lifetime, the lithium-ion battery equips with the protection function to stop the output.

In the cases of 1 to 3 described below, when using this product, even if you are pulling the switch, the motor may stop. This is not the trouble but the result of protection function.

1. When the battery power remaining runs out, the motor stops.  
In such a case, charge it up immediately.
2. If the tool is overloaded, the motor may stop. In this case, release the switch of tool and eliminate causes of overloading. After that, you can use it again.
3. If the battery is overheated under overload work, the battery power may stop.  
In this case, stop using the battery and let the battery cool. After that, you can use it again.

Furthermore, please heed the following warning and caution.

#### **WARNING**

In order to prevent any battery leakage, heat generation, smoke emission, explosion and ignition beforehand, please be sure to heed the following precautions.

1. Make sure that swarf and dust do not collect on the battery.
  - During work make sure that swarf and dust do not fall on the battery.
  - Make sure that any swarf and dust falling on the power tool during work do not collect on the battery.
  - Do not store an unused battery in a location exposed to swarf and dust.
  - Before storing a battery, remove any swarf and dust that may adhere to it and do not store it together with metal parts (screws, nails, etc.).
2. Do not pierce battery with a sharp object such as a nail, strike with a hammer, step on, throw or subject the battery to severe physical shock.

3. Do not use an apparently damaged or deformed battery.
4. Do not use the battery for a purpose other than those specified.
5. If the battery charging fails to complete even when a specified recharging time has elapsed, immediately stop further recharging.
6. Do not put or subject the battery to high temperatures or high pressure such as into a microwave oven, dryer, or high pressure container.
7. Keep away from fire immediately when leakage or foul odor are detected.
8. Do not use in a location where strong static electricity generates.
9. If there is battery leakage, foul odor, heat generated, discolored or deformed, or in any way appears abnormal during use, recharging or storage, immediately remove it from the equipment or battery charger, and stop use.
10. Do not immerse the battery or allow any fluids to flow inside. Conductive liquid ingress, such as water, can cause damage resulting in fire or explosion. Store your battery in a cool, dry place, away from combustible and flammable items. Corrosive gas atmospheres must be avoided.

**CAUTION**

1. If liquid leaking from the battery gets into your eyes, do not rub your eyes and wash them well with fresh clean water such as tap water and contact a doctor immediately.  
If left untreated, the liquid may cause eye-problems.
2. If liquid leaks onto your skin or clothes, wash well with clean water such as tap water immediately.  
There is a possibility that this can cause skin irritation.
3. If you find rust, foul odor, overheating, discolor, deformation, and/or other irregularities when using the battery for the first time, do not use and return it to your supplier or vendor.

**WARNING**

If a conductive foreign matter enters in the terminal of lithium ion battery, the battery may be shorted, causing fire. When storing the lithium ion battery, obey surely the rules of following contents.

- Do not place conductive debris, nail and wires such as iron wire and copper wire in the storage case.
- To prevent shorting from occurring, load the battery in the tool or insert securely the battery cover for storing until the ventilator is not seen.

## REGARDING LITHIUM-ION BATTERY TRANSPORTATION

When transporting a lithium-ion battery, please observe the following precautions.

**WARNING**

Notify the transporting company that a package contains a lithium-ion battery, inform the company of its power output and follow the instructions of the transportation company when arranging transport.

- Lithium-ion batteries that exceed a power output of 100 Wh are considered to be in the freight classification of Dangerous Goods and will require special application procedures.
- For transportation abroad, you must comply with international law and the rules and regulations of the destination country.

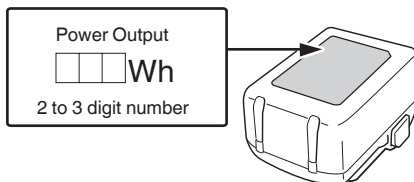

## NAMES OF PARTS (Fig. 1–Fig. 15)













①	Motor	⑲	Latch
②	Nameplate	⑳	Charge indicator lamp
③	Push button	㉑	M5 hex. socket bolt
④	Side handle	㉒	Hex. bar wrench
⑤	Gear cover	㉓	Lever
⑥	Depressed center wheel (sold separately)	㉔	Bump
⑦	Toolless wheel guard	㉕	Notch
⑧	LED light	㉖	Wheel washer
⑨	Switch	㉗	Wheel nut
⑩	Housing	㉘	Wrench
⑪	Switch panel	㉙	With side guard (sold separately)
⑫	Filter	㉚	Abrasive cutting wheel (sold separately)
⑬	Battery	㉛	Guard clip (sold separately)
⑭	Dial	㉜	Diamond wheel (sold separately)
⑮	Auto mode switch	㉝	Remaining battery indicator switch
⑯	Lighting mode switch	㉞	Remaining battery indicator lamp
⑰	Lighting mode indicator lamp	㉟	Soft brush
⑱	Toolless wheel guard (with screw)	㊱	Mesh

## SYMBOLS

**WARNING**







The following show symbols used for the machine. Be sure that you understand their meaning before use.

	G3610DVE / G3613DVE / G3615DVE: Cordless Disc Grinder
	To reduce the risk of injury, user must read instruction manual.
	Always wear eye protection.
V	Rated voltage
n	Rated speed
n <sub>0</sub>	No-load rotation speed

/min	Revolution or reciprocations per minute
D	Wheel outer diameter
d	Wheel hole diameter
t	Wheel thickness
	Peripheral speed
	Weight*
	Switching ON
	Switching OFF
	Disconnect the battery
	Lock
	Unlock
	Auto mode switch
	Lighting mode switch
	Always ON (turn off after 60 minutes)
	Light only SW-ON
	Always OFF
	Warning

\* The weight includes the battery, wheel guard, side handle, wheel washer, and wheel nut.

## Battery

	Lights ; The battery remaining power is over 75%
	Lights ; The battery remaining power is 50%–75%.
	Lights ; The battery remaining power is 25%–50%.
	Lights ; The battery remaining power is less than 25%
	Blinks ; The battery remaining power is nearly empty. Recharge the battery soonest possible.
	Blinks ; Output suspended due to high temperature. Remove the battery from the tool and allow it to fully cool down.
	Blinks ; Output suspended due to failure or malfunction. The problem may be the battery so please contact your dealer.

## STANDARD ACCESSORIES

In addition to the main unit (1 unit), the package contains the accessories listed on page 27.

Standard accessories are subject to change without notice.

## APPLICATIONS

- Removal of casting fin and finishing of various types of steel, bronze and aluminum materials and castings.
- Grinding of welded sections or sections cut by means of a cutting torch.
- Grinding of synthetic resins, slate, brick, marble, etc.
- Cutting of synthetic concrete, stone, brick, marble and similar materials.

## SPECIFICATIONS

### 1. Power tool

The specifications of this machine are listed in the Table on page 26.

### Electronic control

- Soft start  
Reduces recoil against the operator by managing the number of rotations during startup.
- Kickback Protection  
The kickback protection feature cuts off the power to the motor and stops the power tool in the event of a sudden drop in the rotational speed of the wheel during operation (for example, if the wheel locks during cutting operation, etc.).
- Overload protection  
While working, if a load exceeding a certain level is applied, or if the grinding disc is stopped for a certain amount of time, the motor will be stopped to protect the tool and for safety.  
Turn off the switch once, then turn it on again to start up the tool.
- Rotation recovery control function  
While working, if the tool is pressed too forcefully against the surface and the motor stops, if you lift up the tool and lighten the load, rotation will resume.  
Depending on the grinding disc used and the working conditions, the rotation recovery control may be stopped by overload protection.

### CAUTION

- When using ET36A, this function does not operate.
- Overheat protection  
This protection feature cuts off the power to the motor and stops the power tool in the event of overheating of motor during operation.  
When the overheat protection feature has been activated, the motor may stop.  
In this case, release the tool switch and cool it down in a few minutes.  
After that you can use it again.
- Restart prevention function  
When the power is still switched on, the tool will not restart when a battery is installed. This function can be canceled once the tool is switched off.
- Brake function  
Brake activates when the switch is off.

### CAUTION

- When using ET36A, this function does not operate.
- Drop shut off function  
When the drop shut off function has been activated, the motor may stop.  
In this case, release the tool switch.  
After that you can use it again.



# English

## How to make the batteries perform longer.

- (1) Recharge the batteries before they become completely exhausted.  
When you feel that the power of the tool becomes weaker, stop using the tool and recharge its battery. If you continue to use the tool and exhaust the electric current, the battery may be damaged and its life will become shorter.
- (2) Avoid recharging at high temperatures.  
A rechargeable battery will be hot immediately after use. If such a battery is recharged immediately after use, its internal chemical substance will deteriorate, and the battery life will be shortened. Leave the battery and recharge it after it has cooled for a while.

### CAUTION

- If the battery is charged while it is heated because it has been left for a long time in a location subject to direct sunlight or because the battery has just been used, the charge indicator lamp of the charger lights for 0.3 seconds, does not light for 0.3 seconds (off for 0.3 seconds). In such a case, first let the battery cool, then start charging.
- When the charge indicator lamp flickers (at 0.2-second intervals), check for and take out any foreign objects in the charger's battery connector. If there are no foreign objects, it is probable that the battery or charger is malfunctioning. Take it to your authorized Service Center.

## MOUNTING AND OPERATION

Action	Figure	Page
Removing and inserting the battery	2	2
Charging	3	2
Fitting and adjusting the wheel guard	4	3
Fixing the side handle	5	3
Assembling depressed center wheel*1, *2	6	4
Assembling cutting wheel*1, *2	7	4
Assembling diamond wheel*1, *2	8	5
Switch operation	9	5
Switching operation modes*3	10	5
Adjusting the number of revolution*3	11	6
Using the LED light	12	6
Grinding angle and grinding method	13	6
Remaining battery indicator	14	6
Selecting accessories	—	28

\*1 sold separately

### \*2 WARNING

Before use, be sure to tighten the wheel nut with the included wrench.

### NOTE

The wheel washer is specifically for this product. Do not use it for any other product.

\*3 About the mode change function

With Auto mode, you can lower noise and vibration by lowering the maximum number of revolutions while in a no-load state.

While in Auto mode, the number of revolutions will be raised if the load becomes greater during operation. On the other hand, the number of revolutions will be lowered if the load decreases during operation.

### NOTE

- The mode will only change after a battery is installed and the switch is pulled once.
- The current mode will be maintained even if the switch is on/off, or the battery is removed/reinserted.
- Pressing the auto mode switch will change the operating mode back and forth between Auto mode and Transmission mode.  
With Transmission mode, the grinder's number of revolutions can be set at one of six levels using the dial.
- When operating in Transmission mode, the set number of revolutions will be maintained regardless of changes in load.  
Set the mode and dial according to work application. (Table 3)

Table 3

Status	Number of revolutions (/min)		Use
	G3610DVE G3613DVE	G3615DVE	
1	3200	3200	Grinding stainless steel
2	3900	3600	
3	5300	4600	Rust or paint removal Grinding, finishing
4	7400	5600	
5	8600	7200	Rough grinding, cutting
6	10000	8000	
Auto L	5500	5500	Light work, Standby state
Auto H	10000	8000	Grinding, cutting



Auto L: No-load

Auto H: During operation

## LED LIGHT WARNING SIGNALS

This product features functions that are designed to protect the tool itself as well as the battery. While the switch is pulled, if any of the safeguard functions are triggered during operation, the LED light will blink as described in Table 4. When any of the safeguard functions are triggered, immediately remove your finger from the switch and follow the instructions described under corrective action.

Table 4

Safeguard Function	LED Light Display	Corrective Action
Overburden Protection	ON/OFF at 0.1 sec. intervals	Remove the cause of the overloading.
Kickback Protection		
Temperature Protection	ON/OFF at 0.5 sec. intervals 	Allow the tool and battery to thoroughly cool.



## MAINTENANCE AND INSPECTION

### WARNING

Be sure to turned off the switch and remove the battery before maintenance and inspection.

1. **Inspecting the depressed center wheel**  
Ensure that the depressed center wheel is free of cracks and surface defects.
2. **Inspecting the mounting screws**  
Regularly inspect all mounting screws and ensure that they are properly tightened. Should any of the screws be loose, retighten them immediately. Failure to do so could result in serious hazard.
3. **Filter cleaning and inspection (Fig. 15)**

### WARNING

Wear protective glasses and a dust mask when cleaning the filter with an air blow gun.

Failure to do so may result in inhalation or exposure of the eyes to debris or dust.

After use, remove any debris or dust adhered to the filter using a soft brush. Check the filter periodically to ensure that it is free of scratching, chipping, or tearing. Replace with a new filter if the filter is damaged in any way.

### NOTE

- If the mesh is clogged and the debris or dust cannot be removed, detach the filter and clean it with an air gun, etc.
  - After cleaning, make sure to securely attach the filter.
4. **Maintenance of the motor**  
The motor unit winding is the very "heart" of the power tool. Exercise due care to ensure the winding does not become damaged and/or wet with oil or water.

### NOTE

In order to expel debris and dust, periodically run the motor with no load.

5. **Inspection of terminals (tool and battery)**  
Check to make sure that swarf and dust have not collected on the terminals.  
On occasion check prior, during and after operation.

### CAUTION

Remove any swarf or dust which may have collected on the terminals.

Failure to do so may result in malfunction.

6. **Cleaning on the outside**  
When the cordless disc grinder is stained, wipe with a soft dry cloth or a cloth moistened with soapy water. Do not use chloric solvents, gasoline or paint thinner, for they melt plastics.
7. **Storage**  
Store the power tool and the battery in a place in which the temperature is less than 40°C and out of reach of children.

### NOTE

Storing lithium-ion batteries.

Make sure the lithium-ion batteries have been fully charged before storing them.

Prolonged storage (3 months or more) of batteries with a low charge may result in performance deterioration, significantly reducing battery usage time or rendering the batteries incapable of holding a charge.

However, significantly reduced battery usage time may be recovered by repeatedly charging and using the batteries two to five times.

If the battery usage time is extremely short despite repeated charging and use, consider the batteries dead and purchase new batteries.

### Important notice on the batteries for the HiKOKI cordless power tools

Please always use one of our designated genuine batteries. We cannot guarantee the safety and performance of our cordless power tool when used with batteries other than these designated by us, or when the battery is disassembled and modified (such as disassembly and replacement of cells or other internal parts).

### NOTE

Due to HiKOKI's continuing program of research and development, the specifications herein are subject to change without prior notice.

### CAUTION

In the operation and maintenance of power tools, the safety regulations and standards prescribed in each country must be observed.

## 一般安全規則

### ⚠ 警告

閱讀所有安全警告說明

未遵守警告與說明可能導致電擊、火災或其他嚴重傷害。

請妥善保存本使用說明書，以供未來參考之用。

「電動工具」一詞在警告中，係指電源操作（有線）之電動工具或電池操作（無線）之電動工具。

#### 1) 工作場所安全

- a) 保持工作場所清潔及明亮。  
雜亂或昏暗的區域容易發生意外。
- b) 勿在易產生爆炸之環境中操作，譬如有易燃液體、瓦斯或粉塵存在之處。  
電動工具產生火花會引燃粉塵或煙氣。
- c) 當操作電動工具時，確保兒童及過往人員遠離。  
分神會讓您失去控制。

#### 2) 電氣安全

- a) 電動工具插頭必須與插座配合，絕不可以任何方法修改插頭，且不得使用任何轉接插頭於有接地之電動工具。  
不修改插頭及所結合之插座，可減少電擊。
- b) 避免身體接觸到地面，諸如管子、散熱器、爐灶及冰箱。  
如果您的身體接地或觸地，會增加電擊的危險。
- c) 勿讓電動工具淋雨或曝露在潮濕的環境下。  
電動工具進水會增加電擊的危險。
- d) 勿濫用電源線。請勿使用電源線去纏繞、拖拉電動工具或拔插頭，保持電源線遠離熱氣、油氣、尖角或可動零件。  
損壞或纏繞的電源線會增加電擊之危險。
- e) 電動工具在室外操作時，請務必要使用適合室外用的延長線。  
使用合適之室外用延長線會減少電擊的危險。
- f) 若無法避免在潮濕地區操作電動工具，請使用以漏電斷路器 (RCD) 來保護電源。  
使用 RCD，可降低觸電危險。

#### 3) 人員安全

- a) 保持機警，注意您正在做什麼，並運用正確常識操作電動工具。  
當你感到疲勞或受藥品、酒精或醫療影響時，請勿操作電動工具。  
操作中瞬間的不注意，可能造成人員嚴重的傷害。

- b) 使用個人防護裝備，經常配戴安全眼鏡。  
配戴防塵口罩、防滑安全鞋、硬帽等防護裝備，或在適當情況下使用聽覺防護，可減少人員傷害。
  - c) 防止意外發生。在連接電源或電池組、拿起或攜帶工具前，請確認開關是在「off」（關閉）的位置。  
以手指放在開關握持電動工具，或在電動工具的開關於“on”的狀況下插上插頭，都會導致意外發生。
  - d) 在電動工具啟動前，先卸下任何調整用鑰匙或扳手。  
扳手或鑰匙遺留在電動工具的轉動部位時，可能導致人員傷害。
  - e) 身體勿過度伸張，任何時間要保持站穩及平衡。  
以便在不預期的狀態下，能對電動工具有較好的控制。
  - f) 衣著要合宜，別穿太鬆的衣服或戴首飾。  
保持你的頭髮、衣服及手套遠離轉動部位。  
寬鬆的衣服、手飾及長髮會被捲入轉動部位。
  - g) 如果裝置要用於粉塵抽取及集塵設施，要確保其連接及正當使用。  
使用集塵裝置可減少與灰塵相關的危險。
- #### 4) 電動工具之使用及注意事項
- a) 勿強力使用電動工具，使用正確之電動工具為您所需。  
正確使用電動工具，會依其設計條件，使工作做得更好更安全。
  - b) 如果開關不能轉至開或關的位置，勿使用電動工具。  
任何電動工具不能被開關所控制是危險的，必須要修理。
  - c) 進行任何調整、更換配件或收存電動工具時，必須將插頭與電源分開，且需將電池組從電動工具中取出。  
此種預防安全措施，可減少意外開啟電動工具之危險。
  - d) 收存停用之電動工具，需遠離兒童，且不容許不熟悉電動工具或未瞭解操作電動工具說明的人操作電動工具。  
在未受過訓練的人手裡，電動工具極為危險。
  - e) 保養電動工具，檢查是否可動零件有錯誤的結合或卡住、零件破裂及可能影響電動工具操作的任何其他情形。  
電動工具如果損壞，在使用前要修好。  
許多意外皆肇因於不良的保養。
  - f) 保持切割工具銳利清潔。  
適當的保養切割工具，保持銳利之切割鋒口，可減少卡住並容易控制。



- g) 按照說明書使用電動工具、配件及刀具時，必須考量工作條件及所執行之工作。  
若未依照這些使用說明操作電動工具時，可能造成相關之危害情況。
- 5) 充電式工具的使用及注意事項
- 需再充電時，僅能使用製造商指定的充電器。因充電器僅適合同一型式的電池組，若使用任何其它電池組時，將導致起火的危險。
  - 使用電動工具時，僅能使用按照其特性設計的電池組。  
因使用其它任何電池組時，將導致人員傷害及起火的危險。
  - 當電池組不在使用時，需保存遠離其它的金屬物件，例如：迴紋針、錢幣、鑰匙、圖釘、螺釘，或類似能造成端子與端子間連接的其它較小金屬物件。  
因電池組端子間短路時，將導致燃燒或起火的危險。
  - 在誤用情況下，電解液可能自電池中噴出；請避免接觸。當發生意外接觸時，請用清水沖洗。若電解液觸及眼睛時，請儘速尋求醫療協助。  
因自電池中噴出的電解液，將導致灼傷或刺激皮膚。
- 6) 維修
- 讓你的電動工具由合格修理人員僅使用相同的維修零件更換。  
如此可確保電動工具的安全得以維持。

### 注意事項

不可讓孩童和體弱人士靠近工作場所。  
應將不使用的工具存放在孩童和體弱人士伸手不及的地方。

## 對砂輪機或砂輪片操作的通用安全警告

- 該電動工具是用於實現研磨或切斷工具功能的。閱讀隨該電動工具提供的使用說明書內的所有安全警告、說明、圖解和規定。  
不瞭解所列的說明，將導致電擊、著火或嚴重傷害。
  - 不推薦用該電動工具進行諸如砂光、刷光、拋光或切斷等操作。  
電動工具不按指定的功能去操作，可能會發生危險和引起人身傷害。
  - 不使用非工具製造商推薦和專門設計的附件。  
若該附件被裝到您的電動工具上，它可能不能保證操作安全。
- 砂輪片的額定速度，必須至少等於電動工具上標出的最大速度。  
砂輪片在比額定速度大的速度運轉時，會發生爆裂和飛濺。
  - 砂輪片的外徑和厚度，必須在電動工具額定能力範圍之內。  
不正確的砂輪片尺寸，不能得到充分防護或控制。
  - 安裝配件的螺紋必須與砂輪機主軸螺紋相配。對於以法蘭安裝的配件，配件的軸孔必須符合法蘭的定位直徑。  
與電動工具的安裝硬體不相配的配件會失去平衡，劇烈振動，並可能導致失去控制。
  - 不要使用損壞的砂輪片。在每次使用前要檢查砂輪片，例如砂輪片是否有碎片和裂縫，靠背墊是否有裂縫、撕裂或過度磨損，鋼絲刷是否鬆動或金屬絲是否斷裂。如果電動工具或砂輪片跌落了，檢查是否有損壞或安裝沒有損壞的砂輪片。檢查和安裝砂輪片後，讓自己和旁觀者的位置遠離旋轉砂輪片的空間，並以電動工具最大空載速度運行 1 分鐘。  
損壞的砂輪片通常在該試驗時會碎裂。
  - 戴上防護用品。根據操作情況，使用面罩、安全護目鏡或安全眼鏡。必要時，戴上防塵面具、聽力保護器、手套和能擋小磨料或工件碎片的工作圍裙。  
防護用品必須擋住各種操作產生的飛屑。防塵面具或口罩必須能過濾操作產生的顆粒。長期暴露在高強度雜訊中會引起失聰。
  - 讓旁觀者與工作區域保持一定的安全距離。任何進入工作區域的人必須戴上防護用品。  
工件或破損砂輪片的碎片可能會飛出，並引起緊靠著操作區域的旁觀者的傷害。
  - 在鋸切工具可能接觸到隱藏線路之情況下進行操作時，僅握住電動工具的絕緣握持面。  
接觸到「通電」的電線將使電動工具的金屬零件「通電」，而造成操作人員觸電。
  - 讓軟線遠離旋轉的砂輪片。  
如果控制不當，軟線可能被切斷或纏繞，並使得你的手或手臂可能被捲入旋轉砂輪片中。
  - 直到砂輪片完全停止運轉，才可以放下電動工具。  
旋轉的砂輪片可能會抓住表面，並拉動電動工具而讓您失去對工具的控制。
  - 當攜帶電動工具時不要開動它。  
意外觸及旋轉砂輪片，可能會纏繞你的衣服而使砂輪片傷害身體。
  - 經常清理電動工具的通風口。  
砂輪機風扇會將灰塵吸進機殼，過多的金屬粉末沈積會導致電氣危險。
  - 不要在易燃材料附近操作電動工具。  
火星可能會點燃這些材料。
  - 不要使用需用冷卻液的砂輪片。  
用水或其他冷卻液可能會導致電腐蝕或電擊。

## 反衝和相關警告

反衝是因卡住或纏繞住的旋轉砂輪片、靠背墊、鋼絲刷或其他附件而產生的突然反作用力。卡住或纏繞會引起旋轉砂輪片的迅速堵轉，隨之使失控的電動工具在卡住點產生與砂輪片旋轉方向相反的運動。例如，如果砂輪片被工件纏繞或卡住，伸入卡住點的砂輪片邊緣可能會進入材料表面而引起砂輪片飛出或反彈。砂輪片可能飛向或飛離操作者，這取決於砂輪片在卡住點的運動方向。

在此條件下砂輪片也可能碎裂。

反衝是電動工具誤用或不正確操作工序或條件的結果，但透過採取以下適當的預防措施得以避免。

- 保持緊握電動工具，使你的身體和手臂處於正確狀態以抵抗反彈力。如有輔助手柄，則要一直使用，以便最大限度控制住起動時的反彈力或反力矩。  
如採取適當的預防措施，操作者就可以控制反力矩或反彈力。
- 絕不能將手靠近旋轉砂輪片。  
砂輪片可能會反彈碰到手。
- 不要站在發生反衝時，電動工具可能移動到的地方。  
反衝將在纏繞點讓砂輪片轉動方向逆向轉動。
- 當在尖角、銳邊等處作業時要特別小心。避免砂輪片的彈跳和纏繞。  
尖角、銳邊和彈跳具有纏繞旋轉砂輪片的情形，並引起反衝的失控。
- 不要加裝鋸鏈、木雕刀片或帶齒鋸片。  
這些鋸片會產生頻繁的反彈和失控。

## 對砂輪片使用的專用安全警告

- 只使用所推薦的砂輪片型號和為選用砂輪片專門設計的護罩。  
不是為電動工具設計的砂輪片不能充分得到防護，是不安全的。
- 去壓中心輪的磨削表面必須安裝在護刀器唇的平面上方。  
突出護刀器唇平面，未妥善安裝的砂輪片，無法得到適當的保護。
- 護罩必須牢固地裝在電動工具上，且放置得最具安全性，只有最小的砂輪部分暴露在操作人面前。護罩有助於保護操作者免於碰觸到損壞的砂輪碎片，可能點燃衣物的火花，以及與砂輪片的意外接觸。
- 砂輪片只用作推薦的用途。例如：不要用切割砂輪片的側面進行磨削。  
施加到砂輪片側面的力可能會使其碎裂。

- 要經常為砂輪片選用未損壞的、有恰當規格和形狀的砂輪法蘭盤。  
合適的砂輪法蘭盤支撐砂輪片可以減小砂輪片破裂的可能性。切割砂輪片的法蘭盤可以不同於砂輪法蘭盤。
- 不要使用從大規格電動工具上用剩的磨損砂輪片。  
用於大規格電動工具上的砂輪片，不適於較小規格工具的高速工況並可能會爆裂。

## 對砂輪切割操作的附加專用安全警告

- 不要“夾”住砂輪片或施加過大的壓力。不要試圖做過深的切割。  
給砂輪片施加過大的應力，會增加砂輪片在切割時的負載，容易纏繞或卡住，增加了反衝或砂輪片爆裂的可能性。
- 身體不要對著旋轉砂輪片，也不要站在其後。  
當把砂輪片從操作者身邊的操作點移開時，可能的反衝，會使旋轉砂輪片和電動工具朝您衝來。
- 當砂輪片被卡住或任何原因而中斷切割時，關掉電動工具並握住工具不要動，直到砂輪片完全停止。決不要試圖當砂輪片仍然運轉時，讓砂輪片脫離切割，否則會發生反衝。  
調查並採取校正措施以消除砂輪片卡住的原因。
- 不能在工件上重新起動切割操作。讓砂輪片達到全速後再小心地重新進入切割。  
如果電動工具在工件上重新起動，砂輪片可能會卡住、飛出或反衝。
- 過大工件時需使用支撐座，使砂輪片受夾住或產生反衝作用力的風險降到最低。  
大工件由於其自身重量，容易趨於下陷。支撐座必須置於工件下方的砂輪片兩側，靠近鋸切路徑與工件邊緣。
- 在進行牆壁或其他隱蔽區域之局部鋸切時，請格外小心。  
凸出的砂輪片可能會鋸切到瓦斯管、水管、電線或足以產生反衝作用力的物體。

## 砂輪機的一般安全說明

- 確認砂輪片上所標示的轉速等於或大於砂輪機的額定轉速；
- 確保砂輪片尺寸與砂輪機相符；
- 須按照廠家的使用說明書小心存放和使用砂輪；
- 使用前檢查砂輪片，不要使用破損、有裂縫或有其他缺陷的產品；
- 確保所安裝的砂輪片和重點已按照廠家的使用說明固定；
- 在需要時使用吸油紙；

- 在使用前確保已正確安裝並鎖緊砂輪片，並在安全場所的空載狀態下運轉 30 秒鐘，若有較大的振動或察覺到其他缺陷，則應立即停止運轉。遇此情況時，檢查電動工具以究明原因；
- 若電動工具配備保護裝置，切勿在未使用此保護裝置時使用電動工具；
- <G3610DVE> 使用砂輪片切割時，務必先拆下屬於標準配件的砂輪護罩，再裝上附帶側邊護板的砂輪護罩（需另購）（圖 7）；
- <G3613DVE, G3615DVE> 使用砂輪片切割時，務必將切割砂輪用的護夾（另售）安裝在標準配件砂輪護罩上。（圖 7）；
- 請勿使用單獨的異徑軸套或接頭，來適應大孔砂輪片；
- 若要用螺紋孔砂輪片來安裝的工具，需確保砂輪片的螺紋足夠長，以適合軸長；
- 檢查工件已被正確固定；
- 請勿使用切斷砂輪片進行側面研磨；
- 確保使用時產生的火花不會引起危險，例如不要濺在身體上或點燃易燃物；
- 在多塵的條件下工作時，確保通風口暢通無堵塞現象。如果需要清除灰塵，首先使電動工具斷開電源（使用非金屬物品）並避免損壞內部零件；
- 要經常做好視力和聽力的保護。可使用其他個人保護裝置，如口罩、手套、頭盔和圍裙等。
- 在切斷本電動工具的電源之後，砂輪片仍會繼續旋轉一段時間，請特別注意。

### 警告

- 使用切割砂輪時，請務必安裝切割護罩。
- 使用研磨砂輪時，請務必安裝研磨砂輪護罩。

## 附加安全警告

1. 確認要使用的砂輪片是正確類型，無裂縫或表面缺陷。同時也要確保砂輪片安裝妥當，砂輪螺母已牢固鎖緊。
2. 打開電動工具的電源之前，請推動按鈕兩或三次，確認按鈕鬆開。
3. 本機不可施加過大壓力使其過載，以延長使用壽命並確保加工品質。在大部份的用法中，機器本身的重量即夠研磨。加壓過大將導致轉速降低、表面加工不良以及過載，從而縮短機器壽命。
4. 在關閉本電動工具的電源之後，砂輪片仍會繼續旋轉一段時間。  
關掉機器之後，需等電動工具完全停止才能放下，以免造成嚴重事故，而且還可減少吸入機器的塵埃與切削量。
5. 未使用本電動工具時，請斷開電源。
6. 組裝和拆卸盤型研磨輪之前，請務必將開關關閉並取出電池，以避免嚴重事故。

7. 小心因制動器的作用而引起的反衝。  
本充電式圓盤電磨機配備有電動制動器，當開關釋放時會起作用。當制動器起作用時會產生一些反衝，請務必牢固地握住主機身。
8. 如果工具或電池端子（電池座）變形，請勿使用本產品。  
安裝電池可能會造成短路，從而導致冒煙或起火。
9. 保持工具的端子（電池座）沒有削屑和灰塵。  
○ 使用前請確認端子區域沒有堆積削屑和灰塵。  
○ 使用過程中盡量避免工具上的削屑或灰塵掉落在電池上。  
○ 暫停操作或使用後，請勿將工具留在可能暴露於有掉落削屑或灰塵的區域。  
否則可能會造成短路，從而導致冒煙或起火。

## 電池和充電器的注意事項

1. 請務必在 -10 - 40°C 的溫度環境下進行電池的充電。溫度低於 -10°C 會導致充電過度，非常危險。電池不能在高於 40°C 的溫度下充電。  
最適合充電的溫度是 20 - 25°C 之間。
2. 請勿連續使用充電器。  
完成一次充電後，請將充電器擱置大約 15 分鐘，然後再進行下一次充電。
3. 請勿讓異物進入充電電池的連接口內。
4. 切勿拆卸充電電池或充電器。
5. 切勿使充電電池短路。  
電池短路將造成極大電流和過熱。從而燒壞電池。
6. 請勿將電池丟入火中。  
燃燒電池會引起爆炸。
7. 請勿使用耗竭電力的電池，否則將會損壞充電器。
8. 充電後電池壽命若太短不夠使用，請盡快將電池送往經銷店。不可將用過的電池丟棄。
9. 請勿將異物插入充電器的通風口。  
若將金屬異物或易燃物插入充電器的通風口，將引起觸電事故或使充電器受損。

## 鋰離子電池使用注意事項

為延長使用壽命，鋰離子電池備配停止輸出的保護功能。

若是在使用本產品時發生下列 1 至 3 的情況，即使按下開關，馬達也可能停止。這並非故障，而是啟動保護功能的結果。

1. 在殘留的電池電力即將耗盡時，馬達會停止。  
在這種情況下，請立即予以充電。
2. 若工具超過負荷，馬達亦可能停止。在這種情況下，請鬆開工具的開關，試著消除超過負荷的原因。之後您就可以再度使用。

## 中國語

3. 若電池在過載工作情況下過熱，電池電力可能會中止。  
在這種情況下，請停止使用電池，讓電池冷卻。之後您就可以再度使用。

此外，請留心下列的警告及注意事項。

### 警告

為事先防止電池發生滲漏、發熱、冒煙、爆炸及起火等事故，請確保留意下列事項。

- 確保電池上沒有堆積削屑及灰塵。
  - 在工作時確定削屑及灰塵沒有掉落在電池上。
  - 確定所有工作時掉落在電動工具上的削屑和灰塵沒有堆積在電池上。
  - 請勿將未使用的電池存放在曝露於削屑和灰塵的位置。
  - 在存放電池之前，請清除任何可能附著在上面的削屑和灰塵，並請切勿將它與金屬零件（螺絲、釘子等）存放在一起。
- 請勿以釘子等利器刺穿電池、以鐵錘敲打、踩踏、丟擲電池，或將其劇烈撞擊。
- 切勿使用明顯損壞或變形的電池。
- 請依規定方式使用電池，切勿移作他用。
- 如果已過了再充電時間，電池仍無法完成充電，請立即停止繼續充電。
- 請勿將電池放置於高溫或高壓處，例如微波爐、烘乾機或高壓容器內。
- 發現有滲漏或異味時，請立即將電池遠離火源處。
- 請勿在會產生強烈靜電的地方使用。
- 如電池出現滲漏、異味、發熱、褪色或變形，或在使用、充電或存放時出現任何異常，請立即將它從裝備或電池充電器拆下，並停止使用。
- 請勿將電池浸入任何液體，或讓任何液體流入電池內。若水等具有傳導性的液體滲入，可能會造成損壞，進而導致火災或爆炸。將電池存放在陰涼、乾燥的地方，遠離可燃及易燃物品。必須避免腐蝕性氣體環境。

### 注意

- 若電池滲漏出的液體進入您的眼睛，請勿搓揉眼睛，並以自來水等乾淨清水充分沖洗，立刻送醫。若不加以處理，液體可能會導致眼睛不適。
- 若液體滲漏至您的皮膚或衣物，請立即以自來水等清水沖洗。  
上述情況可能會使皮膚受到刺激。
- 若初次使用電池時發現生鏽、異味、過熱、褪色、變形及其他異常情況時，請勿使用並將該電池退還給供應商或廠商。

### 警告

若具有導電性的異物進入鋰離子電池的端子，可能會造成短路，進而引發火災。請在存放電池時遵循以下事項。

- 請勿將導電物品，如鐵釘、鐵絲等金屬絲，銅線和電線放入儲存箱內。

- 為了防止發生短路，將電池裝入工具內或確實壓下電池蓋儲存電池，直至遮住通風孔為止。

## 關於鋰離子電池的運輸

運輸鋰離子電池時，請遵守以下注意事項。

### 警告

安排運輸時，請通知運輸公司包裹中含有鋰離子電池，告知該電池之輸出功率，並按照運輸公司的指示。

- 輸出功率超過 100 Wh 的鋰離子電池被視為貨物分類中的危險物品，將需要特殊的申請程序。
- 對於國外的運輸，必須遵守國際法規則和目的國法規。

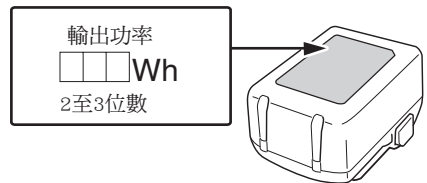

## 各部位名稱（圖1—圖15）

① 馬達	⑱ 門扣
② 銘牌	⑳ 充電指示燈
③ 按鈕	㉑ M5 套筒螺絲
④ 側柄	㉒ 六角棒狀扳手
⑤ 齒輪蓋	㉓ 操作桿
⑥ 凹陷中心砂輪片 (另售)	㉔ 凸塊
⑦ 砂輪護罩	㉕ 槽口
⑧ LED 燈	㉖ 砂輪墊圈
⑨ 開關	㉗ 砂輪螺帽
⑩ 機殼	㉘ 扳手
⑪ 開關面板	㉙ 帶側邊護板 (另售)
⑫ 過濾器	㉚ 砂輪切割片 (另售)
⑬ 電池	㉛ 護罩 (另售)
⑭ 轉盤	㉜ 金剛石砂輪片 (另售)
⑮ 自動模式開關	㉝ 電池剩餘量指示燈開關
⑯ 燈光模式開關	㉞ 電池剩餘量指示燈
⑰ 燈光模式指示燈	㉟ 軟刷
⑱ 免工具砂輪護板 (附螺絲)	㊱ 篩孔



## 符號

## 警告

以下為使用於本電動工具的符號。請確保您在使用前明白其意義。

	G3610DVE / G3613DVE / G3615DVE: 圓盤電磨機
	使用前請詳讀使用說明書
	全程佩戴防護眼鏡
V	額定電壓
n	轉速
n <sub>0</sub>	空載旋轉速度
/min	每分鐘轉數或往復數
D	砂輪外徑
d	砂輪孔徑
t	砂輪厚度
	圓周速度
	重量*
	開關 ON
	開關 OFF
	取出電池
	鎖定
	解鎖
	自動模式開關
	燈光模式開關
	始終開啟 (60 分鐘後關閉)
	僅燈光 SW-ON
	始終關閉
	警告

\* 重量包含電池、砂輪護罩、側把手、砂輪墊圈和砂輪螺帽。

## 電池

	亮起： 電池剩餘電量超過 75%
	亮起： 電池剩餘電量為 50% - 75%
	亮起： 電池剩餘電量為 25% - 50%
	亮起： 電池剩餘電量少於 25%
	閃爍： 電池剩餘電量幾近零。請盡快進行充電
	閃爍： 由於高溫導致輸出被暫停。從工具中取出電池，並使其完全冷卻
	閃爍： 由於故障或機能失常導致輸出被暫停。問題可能是電池，請聯繫您的經銷商

## 標準附件

除了主機身 (1 台) 以外，包裝盒內包含第 27 頁所列之附件。

標準附件可能不預先通告而經予更改。

## 用途

- 用於去除鑄品毛刺，飛邊等物及拋光各種型號的鋼，青銅，鋁及鑄造品。
- 研磨焊接部分或研磨用焊接切割的部分。
- 合成樹脂、石板、磚塊、大理石等的研磨。
- 合成混凝土、石頭、磚塊、大理石和類似材料的切割。

## 規格

## 1. 電動工具

本機器的規格列於第 26 頁的表中。

## 電子控制

- 緩啟動  
管理啟動期間的旋轉次數，以減少對操作者的反作用力。
- 反衝保護  
在運作期間砂輪轉速突然降低的情況下 (例如，如果砂輪在切割運作期間鎖定等)，反衝保護功能會切斷馬達的電源並停止電動工具。

○ 過載保護

進行作業時，如果施加超過一定程度的負載，或如果研磨盤停止一定時間，則馬達將被停止以保護工具和維護安全。

關閉開關一次，然後再次打開以啟動工具。

○ 旋轉恢復控制功能

進行作業時，如果過度用力將工具按壓在表面上，馬達會停止，如果抬起工具並減輕負載，則旋轉將恢復。

根據所使用的研磨盤和作業條件，旋轉恢復控制可能會因過載保護而停止。

注意

使用 ET36A 時，此功能無效。

○ 過熱保護

如果在操作過程中馬達過熱，本保護功能會切斷馬達的電源並停止電動工具。

當過熱保護功能被啟動時，馬達可能會停止。

在這種情況下，請放開工具開關並使其冷卻幾分鐘。

之後您就可以再度使用。

○ 重新啟動預防功能

當電源仍然打開時，安裝電池後本工具將不會重新啟動。一旦工具關閉，則可以取消此功能。

○ 制動功能

開關關閉時制動器啟動。

注意

使用 ET36A 時，此功能無效。

○ 掉落關機功能

當掉落關機已啟動時，馬達可能會停止。

在這種情況下，請放開工具開關。

之後您就可以再度使用。

註

為求改進，本說明書所載規格可能不預先通告而徑予更改。

2. 電池

機型	BSL36A18
電壓	36 V / 18 V (自動切換*)
電池容量	2.5 Ah / 5.0 Ah (自動切換*)

\* 工具本身將自動切換。

## 充 電







使用電動工具之前，按下述方法將電池進行充電。

1. 將充電器的電源線連接到插座。  
當充電器的插頭連接到插座時，充電信號燈會閃爍紅燈（間隔為 1 秒）。
2. 將電池裝入充電器。  
將電池確實插入充電器如圖 3（第 2 頁）所示。
3. 充電  
當電池插入充電器時，充電信號燈會閃爍藍燈。當電池完全充電時，充電信號燈會亮起綠燈。（見表 1）

(1) 充電信號燈指示

依據充電器或充電電池的狀態，充電信號燈會有不同的指示，如表 1 所示。

表 1

充電器狀態	指示燈狀態	指示含義
充電前	每隔 0.5 秒 ON/OFF (紅) 	插頭插入電源 *1
充電時	每隔 1 秒亮燈 0.5 秒 (藍) 	充電低於 50%
	每隔 0.5 秒亮燈 1 秒 (藍) 	充電低於 80%
	持續亮燈 (藍) 	充電高於 80%
充電完成	持續亮燈 (綠)  (連續的蜂鳴聲：約 6 秒)	
過熱待機	每隔 0.3 秒 ON/OFF (紅) 	電池過熱。無法充電。*2
無法充電	每隔 0.1 秒 ON/OFF (紫)  (間歇的蜂鳴聲：約 2 秒)	電池或充電器故障 *3

\*1 如果在連接充電器後紅色指示燈仍持續閃爍，請檢查以確認電池已完全插入。

\*2 儘管電池在原位冷卻後會開始充電，但最佳做法是在充電前將電池取出並在陰涼、通風良好的地方冷卻。

\*3

- 完全插入電池。
- 檢查以確認沒有異物粘附在電池座或端子上。
- < 如果充電時間很長 >
- 在極低的環境溫度下充電將需要更長時間。請在溫暖的地方（例如室內）為電池充電。
- 請勿堵塞通風口。否則內部會過熱，降低充電器的性能。
- 如果冷卻風扇不運作，請聯繫 HiKOKI 授權服務中心進行維修。
- (2) 關於充電電池的溫度和充電溫度  
溫度和充電時間如表 2 中所示。

表 2

機型	UC18YSL3		
電池類型	鋰離子		
充電電壓	14.4 – 18 V		
電池可充電的溫度	0°C – 50°C		
充電時間，電池容量，約（於 20°C）	1.5 Ah	15分	
	2.0 Ah	20分	
	2.5 Ah	25分	
	3.0 Ah	20分 (BSL1830C: 30分)	
	4.0 Ah	26分 (BSL1840M: 40分)	
	5.0 Ah	32分	
	6.0 Ah	38分	
	8.0 Ah	52分	
	多伏特電池	1.5 Ah (×2 單元)	20分
		2.5 Ah (×2 單元)	32分
4.0 Ah (×2 單元)		52分	
電池芯數	4 – 10		
重量	0.6 kg		

註

充電時間可能依環境溫度而有所不同。

4. 將充電器的電源線從插座拔下。
5. 拿穩充電器並取出電池。

註

充電結束後，務必從充電器取出電池，然後妥善存放。

**使用新電池或其他電池，產生電量較弱的問題時**

由於新電池及長時間未使用之電池的內部化學物質未活化，因此初次及第二次使用時的電量會較弱。此為暫時現象；在充電 2 至 3 次後，電量就會恢復正常。

**怎樣讓電池使用時間更長**

- (1) 在電池電量完全耗盡之前給電池充電。  
在感覺工具的動力變弱時，停止使用工具並為電池充電。如果繼續使用工具消耗電流，可能會造成對電池的損壞，電池使用壽命會縮短。
- (2) 避免在高溫下充電  
充電電池在剛使用後會發熱。如果在電池剛使用後為電池充電，電池的內部化學物質的性能會下降，電池使用壽命會縮短。請先將電池放置一會兒，待電池冷卻後再進行充電。

注意

- 電池因長時間放置在直射陽光處遭到日曬或剛使用後會發熱，若在此時進行充電，充電器的信號燈會亮起 0.3 秒，非亮起 0.3 秒（熄滅 0.3 秒）。此時您必須先待電池冷卻，再進行充電。
- 充電信號燈快速閃爍時（間隔時間為 0.2 秒），請檢查充電器的電池連接處是否有異物並加以清除。若沒有異物，則表示電池或充電器可能發生故障，請將其送往當地授權服務中心。

**安裝和操作**

動作	圖表	頁數
拆卸和安裝電池	2	2
充電	3	2
安裝並調整輪罩	4	3
固定側柄	5	3
組裝盤型研磨輪 *1, *2	6	4
組裝切割輪 *1, *2	7	4
組裝金剛石輪 *1, *2	8	5
開關操作	9	5
開關操作模式 *3	10	5
調整轉數 *3	11	6
使用 LED 燈	12	6
研磨角度和研磨方法	13	6
電池剩餘電量指示器	14	6
選擇附件	—	28

\*1 另售

\*2 警告

使用前務必用隨附的扳手鎖緊砂輪螺帽。

註

砂輪墊圈為本產品專用。請勿將其用於任何其他產品。





## 6. 清理外部

充電式圓盤電磨機髒汙時，請使用乾的軟布或沾肥皂水的布擦拭。切勿使用氯溶液、汽油或稀釋劑，以免塑膠部分溶化。

## 7. 收藏

電動工具和電池應收藏於溫度低於 40°C 且為小孩拿不到的地方。

### 註

存放鋰離子電池

存放鋰離子電池前，確保其已完全充電。

電池在低電力的狀態下長期存放（3 個月以上），可能會導致性能劣化，電池的使用時間顯著降低或無法再進行充電。

然而，反覆將電池充電和暫停充電二至五次，可能會改善電池使用時間的顯著降低情況。

反覆充電後，若電池的使用時間仍呈現極短現象，表示電池壽命已盡，請購買新的電池。

### 注意



在操作和維修電動工具中，必須遵守各國的安全規則和標準規定。



#### HiKOKI 充電式工具電池重要注意事項

請務必使用本公司所指定的原廠電池。若未使用本公司所指定的電池，或使用經拆解及改裝的電池（例如，拆解後更換電池芯或其他內部零件），則本公司無法保證充電式工具的性能及操作安全。

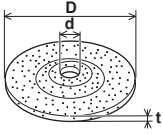
#### 註：

為求改進，本說明書所載規格可能不預先通告而徑予更改。

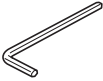
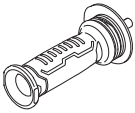
	G3610DVE	G3613DVE	G3615DVE	
V	36 V			
n	3200–10000 /min A: 5500 /min		3200–8000 /min A: 5500 /min	
	D	100 mm	125 mm	
	d	16 mm	22.23 mm	
	t	6 mm		
	72 m/s	80 m/s		
	2.8 kg (BSL36A18) 3.0 kg (BSL36B18)	3.0 kg (BSL36A18) 3.3 kg (BSL36B18)	3.1 kg (BSL36A18) 3.4 kg (BSL36B18)	

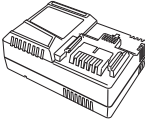
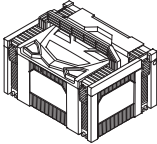
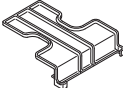
	G3610DVE		G3613DVE, G3615DVE	
	(2XC)	(NNP)	(2XC)	(NNP)
	1	1	1	1
	1	1	-	-
	1	1	1	1
 BSL36A18	2	-	2	-
 UC18YSL3	1	-	1	-
	1	1	1	1
	2	-	2	-

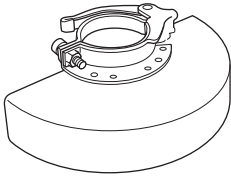

100 mm : 379563

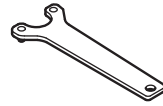

100 mm : 313933  
125 mm, 150 mm : 938332Z

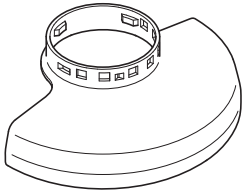

125 mm : 379445  
150 mm : 379446

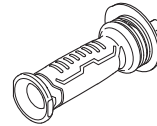

336865



100 mm : 373072  
125, 150 mm : 376500

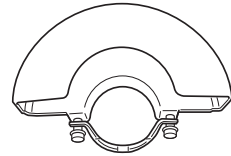

100 mm : 302099

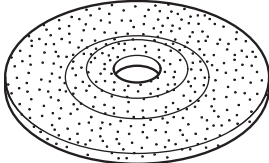

100 mm : 316820 (A36Q)  
125 mm : 316822 (A36Q)  
150 mm : 316823 (A36Q)

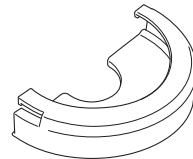

125 mm : 372701  
150 mm : 379593



100 mm : 339578  
125, 150 mm : 373779

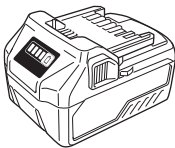

BSL36A18

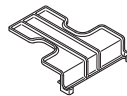

329897

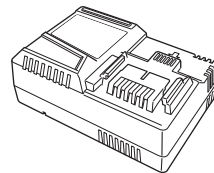

UC18YSL3  
(14.4 V-18 V)

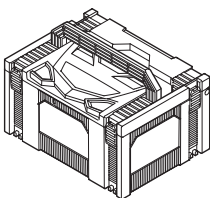

337108

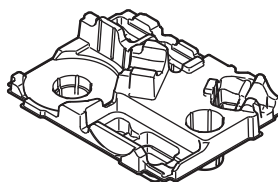

379422



379591

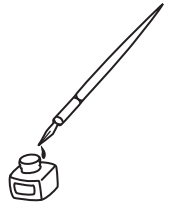

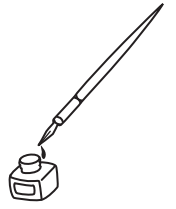

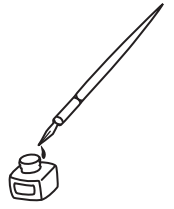

臺灣總代理：

明峯永業股份有限公司

電話：**(02) 2792 - 0123**

地址：臺北市內湖區新湖二路211號

網址：**<https://www.hikoki-powertools.com.tw>**

服務信箱：**[service@powertools.com.tw](mailto:service@powertools.com.tw)**

# Koki Holdings Co., Ltd.

Shinagawa Intercity Tower A, 15-1, Konan 2-chome,  
Minato-ku, Tokyo, Japan