

HiKOKI

中文
English

充电式冲击扳手
Cordless Impact Wrench

WR 36DF · WR 36DG

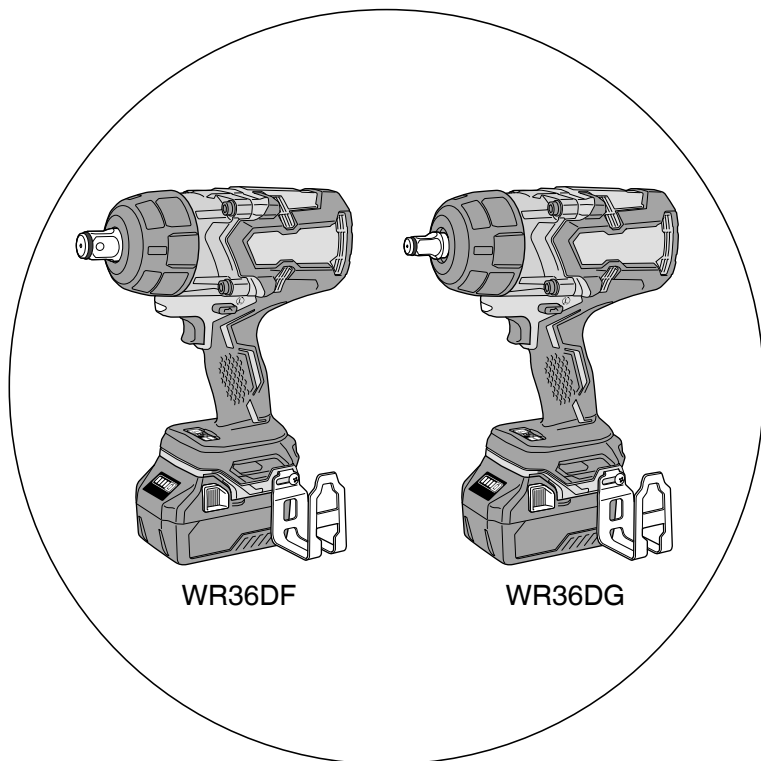

保留备用
Keep for future reference



使用说明书
Handling instructions

目次

电动工具通用安全警告.....	2	用途.....	12
充电式冲击扳手安全警告.....	5	电池的拆卸 / 安装法.....	12
锂离子电池使用注意事项.....	6	充电.....	13
锂离子电池运输.....	8	作业之前.....	16
USB 设备连接器使用注意事项.....	8	使用方法.....	18
防尘和防水功能注意事项.....	9	操作上的注意事项.....	25
符号.....	9	USB 设备的充电方法.....	26
零件名称.....	10	维护和检查.....	27
规格.....	11	故障排除.....	29
标准附件.....	12	选择附件.....	30

电动工具通用安全警告

⚠ 警告！

阅读电动工具附带的所有安全警告、说明、插图和规格说明。
不遵照以下说明会导致电击、着火和 / 或严重伤害。

保存所有警告和说明书以备查阅。

在所有下列的警告中术语“电动工具”指市电驱动（有线）电动工具或电池驱动（无线）电动工具。

1) 工作场地的安全

- a) 保持工作场地清洁和明亮。
混乱和黑暗的场地会引发事故。
- b) 不要在易爆环境，如有易燃液体、气体或粉尘的环境下操作电动工具。
电动工具产生的火花会点燃粉尘或气体。
- c) 让儿童和旁观者离开后操作电动工具。
注意力不集中会使操作者失去对工具的控制。

2) 电气安全

- a) 电动工具插头必须与插座相配。
绝不能以任何方式改装插头。
需接地的电动工具不能使用任何转换插头。
未经改装的插头和相配的插座将减少电击危险。
- b) 避免人体接触接地表面，如管道、散热片和冰箱。
如果你身体接地会增加电击危险。
- c) 不得将电动工具暴露在雨中或潮湿环境中。
水进入电动工具将增加电击危险。

- d) 不得滥用电线。绝不能用电线搬运、拉动电动工具或拔出其插头。
使电线远离热源、油、锐边或运动部件。
受损或缠绕的软线会增加电击危险。
- e) 当在户外使用电动工具时，使用适合户外使用的外接软线。
适合户外使用的软线将减少电击危险。
- f) 如果在潮湿环境下操作电动工具是不可避免的，应使用剩余电流动作保护器（RCD）。
使用RCD可减小电击危险。

3) 人身安全

- a) 保持警觉，当操作电动工具时关注所从事的操作并保持清醒。
当你感到疲倦，或在有药物、酒精或治疗反应时，不要操作电动工具。
在操作电动工具时瞬间的疏忽会导致严重人身伤害。
- b) 使用个人防护装置。始终佩戴护目镜。
安全装置，诸如适当条件下使用防尘面具、防滑安全鞋、安全帽、听力防护等装置能减少人身伤害。
- c) 防止意外起动。确保开关在连接电源和 / 或电池盒、拿起或搬运工具时处于关断位置。
手指放在已接通电源的开关上或开关处于接通时插入插头可能会导致危险。
- d) 在电动工具接通之前，拿掉所有调节钥匙或扳手。
遗留在电动工具旋转零件上的扳手或钥匙会导致人身伤害。
- e) 手不要伸展得太长。时刻注意立足点和身体平衡。
这样在意外情况下能很好地控制电动工具。
- f) 着装适当。不要穿宽松衣服或佩戴饰品。让衣服、手套和头发远离运动部件。
宽松衣服、佩饰或长发可能会卷入运动部件中。
- g) 如果提供了与排屑、集尘设备连接用的装置，要确保它们连接完好且使用得当。
使用这些装置可减少尘屑引起的危险。
- h) 请勿因频繁使用工具的熟悉感而掉以轻心，忽视工具的安全性原则。
粗心的行为可能会导致瞬间发生严重伤害。

4) 电动工具使用和注意事项

- a) 不要滥用电动工具，根据用途使用适当的电动工具。
选用适当设计的电动工具会使你工作更有效、更安全。
- b) 如果开关不能接通或关断工具电源，则不能使用该电动工具。
不能用开关来控制的电动工具是危险的且必须进行修理。
- c) 在进行任何调整、更换附件或存放电动工具之前，必须从电源上拔掉插头和 / 或取下电池盒（如果可拆卸）。
这种防护性措施将减少工具意外起动的危险。

- d) 将闲置不用的电动工具贮存在儿童所及范围之外，并且不要让不熟悉电动工具或对这些说明不了解的人操作电动工具。
电动工具在未经培训的用户手中是危险的。
- e) 维护电动工具和附件。检查运动件是否调整到位或卡住，检查零件破损情况和影响电动工具运行的其他状况。如有损坏，电动工具应在使用前修理好。
许多事故由维护不良的电动工具引发。
- f) 保持切削刀具锋利和清洁。
保养良好的有锋利切削刃的刀具不易卡住而且容易控制。
- g) 按照使用说明书，考虑作业条件和进行的作业来使用电动工具、附件和工具的刀头等。
将电动工具用于那些与其用途不符的操作可能会导致危险。
- h) 保持手柄和抓握表面干燥、清洁，远离油和油脂。
如果手柄和抓握表面湿滑，可能导致在发生意外情况时，无法安全操作和控制工具。

5) 电池式工具使用和注意事项

- a) 只用制造商规定的充电器充电。
将适用于某种电池盒的充电器用到其他电池盒时会发生着火危险。
- b) 只使用配有特制电池盒的电动工具。
使用其他电池盒会发生损坏和着火危险。
- c) 当电池盒不用时，将它远离其他金属物体，例如回形针、硬币、钥匙、钉子、螺钉或其他小金属物体，以防一端与另一端连接。
电池端部短路会引起燃烧或火灾。
- d) 在滥用条件下，液体会从电池中溅出；避免接触。如果无意间碰到了，用水冲洗。如果液体碰到了眼睛，还要寻求医疗帮助。
从电池中溅出的液体会发生腐蚀或燃烧。
- e) 请勿使用损坏或改装的电池盒或工具。
损坏或改装的电池可能会引发突发状况，导致火灾、爆炸或受伤。
- f) 请勿将电池盒或工具暴露在有火源或高温环境中。
如果暴露在有火源或 130 度以上高温的环境中，可能引起爆炸。
- g) 请完全按照充电说明进行操作，不要在说明中规定的温度范围外的环境中对电池盒或工具充电。
充电不当或在规定温度范围外的环境中充电可能会导致电池损坏，增加发生火灾的风险。

6) 维修

- a) 将你的电动工具送交专业维修人员，使用同样的备件进行修理。
这样将确保所维修的电动工具的安全性。
- b) 请勿维修已损坏的电池盒。
需由制造商或经授权的服务供应商进行维修。

注意！

不可让儿童和体弱人士靠近工作场所。

应将不使用的工具存放在儿童和体弱人士接触不到的地方。

充电式冲击扳手安全警告

1. 在执行紧固件可能会接触到暗线的操作时，通过绝缘的抓紧表面拿住电动工具。接触“带电”电线的紧固件会使电动工具的裸露金属部件“带电”，并可能使操作员遭到电击。
2. 这是用于拧紧和旋松螺栓和螺母的手提式工具。请仅用于这些操作。
3. 长时间使用时请戴上耳塞。
4. 在操作期间请务必牢牢握住工具。
否则可能导致事故或人身伤害。（图 1）
5. 检查套筒是否破裂或损坏，破裂或损坏的套筒很危险。使用前请检查套筒。
6. 用套筒销和套筒环固定套筒。
如果固定套筒的套筒销或套筒环损坏，套筒就可能从冲击扳手上脱落，这是很危险的。请勿使用变形、磨损、破裂等损坏的套筒销或套筒环。务必将套筒销和套筒环装在正确的位置。
7. 检查拧紧扭矩。
拧紧螺丝所需的适当转矩取决于螺栓的材料、尺寸和等级等。
由此冲击扳手产生的拧紧扭矩还取决于螺栓的材料、尺寸、装上套筒的本冲击扳手的使用时间等。
电池刚充电和将耗尽时的转矩也有些许不同。请用转矩扳手检查是否用适当的转矩拧紧了螺栓。
8. 切换旋转方向前请停下本冲击扳手。切换旋转方向前请放开开关，并等待冲击扳手停下。
9. 切勿触摸转动部分。
请勿让转动着的套筒部分接近手或身体的其它部分，否则会被割伤或被夹入套筒。长时间持续使用套筒后请注意不要触摸套筒，因为套筒会变得很热，从而可能会被烫伤。
10. 使用万向接头时切勿在没有负载的情况下转动冲击扳手。
如果在没有连接负载的情况下转动套筒，万向接头会使套筒转动失控。从而可能会使您受伤，或者套筒的转动可能会强烈震动冲击扳手使其掉下。
11. 如果发现本机正在产生异常高温、工作不正常或出现异常噪音，请立即停止使用，并关闭电源。请让本机的经销商或 HiKOKI 授权服务中心检查和修理。操作出现异常而依然继续使用时，可能会造成人身伤害。



图 1

12. 如果本机意外跌落或撞击其他物体，请彻底检查其是否发生破裂、破损或变形等。
如果本机破裂、破损或变形，可能会造成人身伤害。
13. 在较高的位置作业时，请确保下方没有人，并注意下方的情况。
14. 务请在 $0^{\circ}\text{C} - 40^{\circ}\text{C}$ 的温度下进行充电。温度低于 0°C 将会导致充电过度，极其危险。电池不能在高于 40°C 的温度下充电。
最适合于充电的温度是 $20 - 25^{\circ}\text{C}$ 。
15. 不要连续使用充电器。
一次充电完毕后，在 15 分钟内不要再次使用该充电器对电池充电。
16. 勿让杂质进入电池连结口内。
17. 切勿拆卸电池与充电器。
18. 切勿使电池短路。使电池短路将会造成很大的电流和过热，从而烧坏电池。
19. 请勿将电池丢入火中。
电池受热将会爆炸。
20. 请勿将异物插入充电器的通风口。
若将金属异物或易燃物插入通风口的话，将会引起触电事故或使充电器受损。
21. 充电后电池寿命太短不够使用时，请尽快将电池送往经销店。请勿将用过的电池乱丢。
22. 请勿使用耗竭了的电池，否则会损坏充电器。
23. 请确保蓄电池安装牢固。电池松动后，可能脱落并引起事故。
24. 请勿使用工具或电池端子（电池安装部位）明显变形的产品。
否则，安装电池后可能会短路，造成冒烟或起火。
25. 请清除工具端子（电池安装部位）上的削屑和灰尘。
 - 使用前请确保电池上没有堆积削屑和灰尘。
 - 在使用过程中，请尽量避免工具上的削屑或灰尘掉落在电池上。
 - 暂时不使用工具时或使用后，应将工具存放在不会掉落削屑或灰尘的地方。
否则可能短路，造成冒烟或起火。
26. 请在 $-5^{\circ}\text{C} - 40^{\circ}\text{C}$ 环境下使用本工具及电池。

锂离子电池使用注意事项

为延长使用期限，锂离子电池备配停止输出的保护功能。

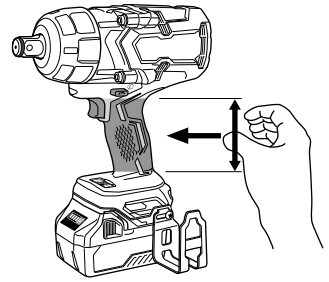
若是在使用本产品时发生下列 1 至 3 的情况，即使按下开关，马达也可能停止。这并非故障，而是启动保护功能的结果。

1. 在残留的电池电力即将耗尽时，马达会停止。
在这种情况下，请立即予以充电。
2. 若工具超过负荷，马达亦可能停止。在这种情况下，请松开工具的开关，试着消除超过负荷的原因。之后您就可以再度使用。

3. 若电池在过载工作情况下过热，电池电力可能会中止。

在这种情况下，请停止使用电池，让电池冷却。之后您就可以再度使用。此外，请留心下列的警告及注意事项。

警告！

为防止发生电池漏电、发热、冒烟、爆炸及提前点燃，请确保留意下列事项。

1. 确保电池上没有堆积削屑及灰尘。

○ 在工作时确定削屑及灰尘没有掉落在电池上。

○ 确定所有工作时掉落在电动工具上的削屑和灰尘没有堆积在电池上。

○ 请勿将未使用的电池存放在曝露于削屑和灰尘的位置。

○ 在存放电池之前，请清除任何可能附着在上面的削屑和灰尘，并请切勿将它与金属零件（螺丝、钉子等）存放在一起。

2. 请勿以钉子等利器刺穿电池、以铁锤敲打、踩踏、丢掷电池，或将其剧烈撞击。

3. 切勿使用明显损坏或变形的电池。

4. 请依规定方式使用电池，切勿移作他用。

5. 如果已过了再充电时间，电池仍无法完成充电，请立即停止继续再充电。

6. 请勿将电池放置于高温或高压处，例如微波炉、烘干机或高压容器内。

7. 在发觉有渗漏或异味时，请勿接近远离火源。

8. 请勿在会产生强烈静电的地方使用。

9. 如有电池渗漏、异味、发热、褪色或变形，或在使用、充电或存放时出现任何异常，请立即将它从装备或电池充电器拆下，并停止使用。

10. 请勿浸泡电池或让任何液体流入电池内部。导电液体进入（如水），可能造成电池损坏，甚至可导致火灾或爆炸。将电池存放在阴凉、干燥的地方，远离易燃物品。必须避免将电池置于腐蚀性气体环境中。

注意！

1. 若电池渗漏出的液体进入您的眼睛，请勿搓揉眼睛，并以自来水等干净清水充分冲洗，立刻送医。

若不加以处理，液体可能会导致眼睛不适。

2. 若液体渗漏至您的皮肤或衣物，请立即以自来水等清水冲洗。

上述情况可能会使皮肤受到刺激。

3. 若初次使用电池时发现生锈、异味、过热、褪色、变形及 / 或其它异常情况时，请勿使用并将该电池退还给供货商或厂商。

警告！

如果导电异物接触到锂离子电池的端子，电池可能短路，并导致火灾。

存放锂离子电池时，请务必遵循下列注意事项。

- 切勿在存放盒中放置导电的残片，钉子，以及导线，如铁线和铜线。
- 或者将电池装在电动工具中，或者在牢固按入电池盖并挡住通风孔后再存放，以防止短路。（参照图 2）



图 2

锂离子电池运输

当运输一个锂离子电池，请注意以下预防措施。

警告！

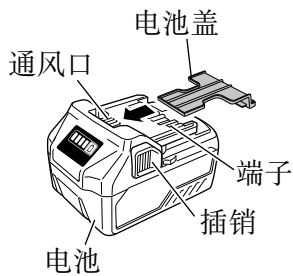
告知运输公司，包装内包含一个锂离子电池，告知该公司其功率输出并且要按照运输公司的指引安排运输。

- 功率输出超过 100 Wh 的锂离子电池被视作危险物品运输分类并且需要特别申请程序。
- 对于境外运输，您必须遵守国际法以及输入国的规章和条例。



图 3

USB 设备连接器使用注意事项

发生意外情况时，本产品连接的 USB 中保存的数据可能发生损坏或丢失。使用本产品前，请务必备份 USB 设备中的数据。

请注意，如 USB 设备中存储的数据发生损坏、丢失或连接的设备发生损坏，本公司概不负责。

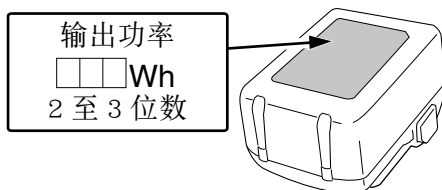
防尘和防水功能注意事项

本产品符合国际 IEC 标准中规定的电气设备 IP56 防护等级（防尘和防水）。（装有电池时，仅重要的组件符合 IP56 防护等级。）

[IP 代码描述]

IP56

防水等级

强水流从各方向喷射时务必不会对设备产生不良影响（防水）。
（使用直径 12.5mm 的喷嘴时，请在距离 3 米左右处进行喷射，每分钟喷射 100L 水，每个方向喷射约 3 分钟。）

固体异物侵入防护等级

完全杜绝灰尘落入对设备造成不良干扰（防尘）。
（将设备在实验室中静置 8 小时，使用搅拌机以 2 千克 / 立方米的速度将滑石粉颗粒的直径搅拌至 $75 \mu\text{m}$ 以下，使其漂浮在空中。）

虽然设备已配备了防尘、防水设计，但并不能排除发生故障的可能性。请勿将设备放置在可能会存在大量灰尘、溅到大量水或雨水的环境中。

符号

警告！

如下所示的符号用于本机。使用前请务必理解其含意。

	为降低伤害风险，用户必须阅读使用说明书	n_0	空载转速
	直流电	/min	每分钟的振动次数
V	额定电压		警告

零件名称

1. 电动工具



图 4

2. 电池

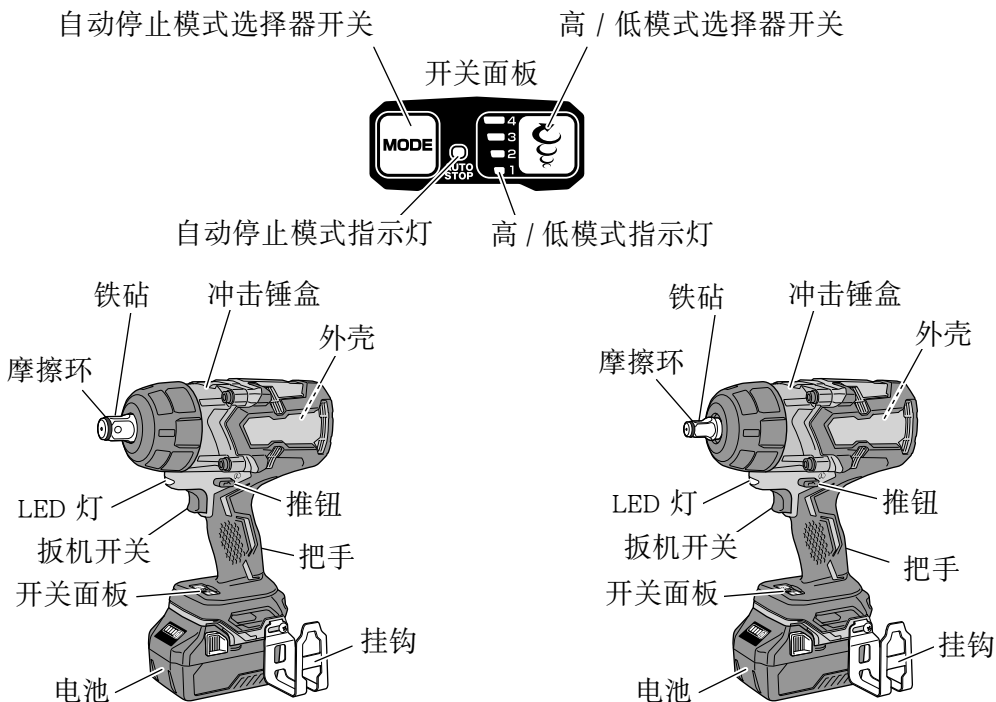

图 5

3. 电池充电器

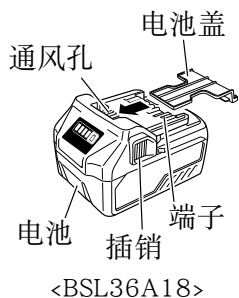

图 6

规格

电动工具

型式		WR36DF	WR36DG
电压		36 V	
空载转速	模式 4	0—1500 /min	
	模式 3	0—1200 /min	
	模式 2	0—900 /min	
	模式 1	0—600 /min	
能力	普通螺栓	M12—M36	M12—M33
	高强度抗拉螺栓	M10—M27	M10—M24
旋紧扭矩		最大 1900 N·m	最大 1400 N·m
方榫尺寸		19 mm	12.7 mm
电池 *		BSL36A18 : 锂离子 36 V / 18 V (2.5 Ah / 5.0 Ah 10 节)	
重量		3.9 kg (安装 BSL36A18)	

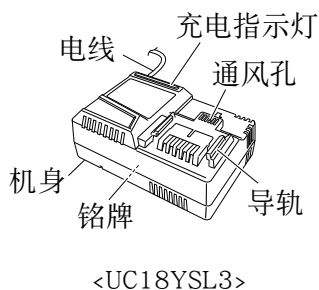
* 本工具不适用以下电池 (BSL3660/3626/3620、BSL18xx 和 BSL14xx 系列)。

充电器

型式	UC18YSL3
充电电压	14.4—18 V
重量	0.6 kg

标准附件

除了主机 (1 台) 外，产品包中还包括表中所列的附件。

表 1

		WR36DF, WR36DG	
		2XCP	NNP
充电器 (UC18YSL3)		1	—
电池 (BSL36A18)		2	—
电池盖		1	—
外壳 (可堆叠)		1	1

根据工具套件的规格不同，所提供的充电器和电池会有所不同。

用途

拧紧和旋松用于固定结构部件的任何类型的螺栓和螺母。

电池的拆卸 / 安装法

1. 电池的拆卸法

请先紧抓住把手、然后再推压电池插销以拆下电池 (参照图 7)。

注意！

切勿使电池短路。

2. 电池的安装法

插入电池时请注意极性 (参照图 7)。



图 7

中文

- *1 如果即便在已安装充电器后红灯仍然继续闪烁，则检查以确认电池已经完全插入。
- *2 尽管电池留在原位，一旦其已冷却，充电仍将会开始；但最佳操作还是取下电池，并在充电前使其在阴凉、通风良好处进行冷却。
- *3
 - 完全插入电池。
 - 检查以确认电池槽或端子处无异物卡住。
 - < 如充电时间很长 >
 - 在极低环境温度中，充电将花费更长时间。在温暖位置（如室内）对电池进行充电。
 - 请勿堵塞通风口。否则内部将会过热，从而降低充电器的性能。
 - 如果冷却风扇不运行，请联系 HiKOKI 授权的维修中心进行维修。

(2) 可充电电池温度和充电时间相关资料。
温度和充电时间如表 3 所示。

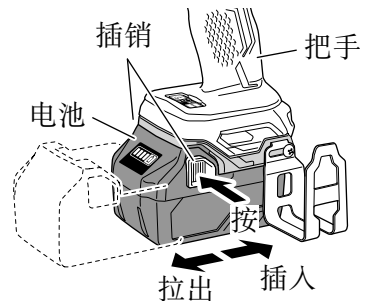
表 3

电池		充电器	UC18YSL3	
电池类型			锂离子	
充电电压			14.4—18 V	
可对电池进行充电的温度			0°C—50°C	
电池容量的充电时间， 约为（在 20°C 时）		1.5 Ah	15 分钟	
		2.0 Ah	20 分钟	
		2.5 Ah	25 分钟	
		3.0 Ah	20 分钟 (BSL1430C, BSL1830C: 30 分钟)	
		4.0 Ah	26 分钟 (BSL1840M: 40 分钟)	
		5.0 Ah	32 分钟	
		6.0 Ah	38 分钟	
		8.0 Ah	52 分钟	
	多电压系列		1.5 Ah (× 2 机)	20 分钟
			2.5 Ah (× 2 机)	32 分钟
		4.0 Ah (× 2 机)	52 分钟	
电池数量			4—10	
USB 充电电压			5 V	
USB 充电电流			2 A	
重量			0.6 kg	

注：

充电时间可能会因环境温度和电源电压而异。

4. 从电源插座拔下充电器的电源线。
5. 握紧充电器并取出电池。

注：

充电后，先将电池从充电器中取出，然后妥善保存。

关于新电池的放电。

新电池内部的化学物质未被激活或电池长时间不使用时，初次或第二次使用时需要将其放电至较低电量。这只是暂时现象，将电池充电 2-3 次即可恢复为充电所需的正常时间。

较长时间保持电池性能的方法

- (1) 在电池电力完全耗尽之前进行充电。
感到电动工具的能力变弱时，请停止使用并给电池充电。若您继续使用电动工具并耗尽电力，电池可能会损坏或其使用寿命缩短。
- (2) 避免在高温环境中充电。
使用后可充电电池的温度将迅速升高。若使用后立即对这种电池进行充电，其内部化学物质会劣化，电池使用寿命将缩短。请稍等片刻，待电池冷却后再进行充电。

注意！

- 如果电池长时间放置在阳光直射的地方或者刚刚使用完毕时，电池会变热。如果此时对电池充电，充电器的充电指示灯会点亮 0.3 秒钟，然后熄灭 0.3 秒钟（熄灭 0.3 秒钟）。此时请等待电池冷却后再开始充电。
- 充电指示灯闪动（闪动间隔为 0.2 秒钟）时，请检查充电器的电池连接器内是否有异物并加以清除。如没有异物，则可能是电池或充电器发生了故障。请将其送往当地授权服务中心。

作业之前

1. 准备和检查工作环境
确认工作场所满足使用注意事项中所述的所有条件。
2. 检查电池
确认已紧紧装上电池。如果松弛则电池可能会脱开，并造成事故。
3. 选择适合螺栓的套筒
使用的套筒务必适合要拧紧的螺栓。使用不适合的套筒不仅不能充分拧紧，还会损伤套筒或螺母。
磨损或变形的六角或方孔套筒不能为螺母或铁砧提供适当的固定拧紧力，从而导致拧紧扭矩的损失。
请注意套筒孔的磨损，并在进一步磨损前更换。

4. 安装套筒
选择要使用的套筒。

注意！

请使用操作手册和 HiKOKI 商品说明书中指定的附件。否则可能会导致事故或受伤。

● 销、O 型环型 <WR36DF>

- (1) 将 O 型环滑出凹槽，将套筒孔与铁砧孔对齐，将铁砧插入套筒。(图 9)



图 9

- (2) 将销插入套筒。(图 10)

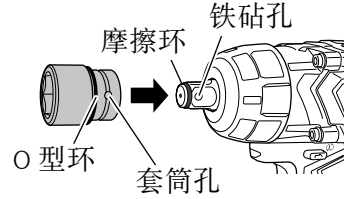

图 10

- (3) 确保销不会脱落后，将 O 型环装在套筒的凹槽上。(图 11, 12)



图 11

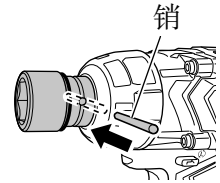

图 12

注意！

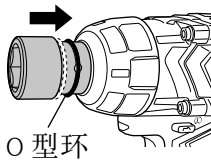
- 务必将套筒紧紧装入铁砧。否则套筒可能会脱落，并造成受伤。
- 将 O 型环滑出套筒的凹槽时，小心不要将销掉落或丢失。

中文

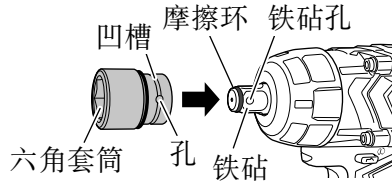
● <WR36DG> (图 13)

- (1) 将套筒的方孔部分和铁砧对齐。
- (2) 将套筒完全推入铁砧，以确保牢固安装。
- (3) 拆卸套筒时，将其从铁砧中拉出。



图 13

注意！

务必将套筒紧紧装入铁砧。否则套筒可能会脱落，并造成受伤。

使用方法

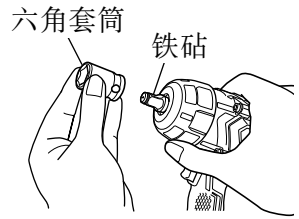
1. 检查旋转方向

推动选择按钮的 R (右) 侧，钻头便会顺时针 (从后方看时) 旋转
按推钮的 L (左) 侧使钻头逆时针旋转。(参照图 14)。(机身上标有 (L) 和 (R) 标记。)



图 14

注意！

冲击扳手运转时，无法切换推钮。如需切换推钮，将冲击扳手停止运转后再切换推钮。

2. 开关操作

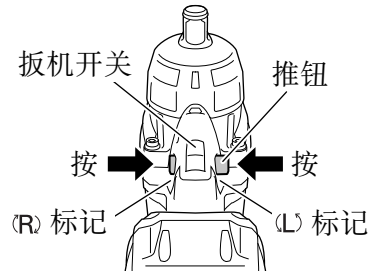
- 压下扳机开关，则本机旋转；松开扳机开关，则本机停止。
- 可通过改变扳机开关的扣动幅度来控制转速。幅度小则转速低，幅度大则转速高。
- 松开扳机开关时，制动器将立即停止。

注：

当马达即将起转时，可能会产生一种嗡嗡声；这只不过是一种噪音，而非机器故障。

3. 拧紧和拧松螺栓

首先必须选择与螺栓或螺母相对应的六角扳手。接下来，将套筒安装到铁钻上，用六角扳手咬住要拧紧的螺母。将扳手按在螺栓上，按电源开关冲击螺母几秒钟。

如果螺母松动地安装到螺栓上，螺栓可能随着螺母转动，则说明未正确拧紧。在此情况下，停止冲击螺母，用扳手按住螺母头后重新启动冲击，或者手动拧紧螺栓和螺母，以防它们滑动。

4. 使用挂钩

挂钩可用于在工作时临时挂起本机。(图 15)

注意！

请勿用挂钩悬挂人。

使用挂钩时，请确保主要机体会不会滑倒或倒落，或被风吹动等。

请勿将机器挂在腰带或裤子上，否则可能会导致事故。



图 15

(1) 卸下挂钩。

用十字螺丝刀卸下用于固定挂钩的螺丝。

(图 16)

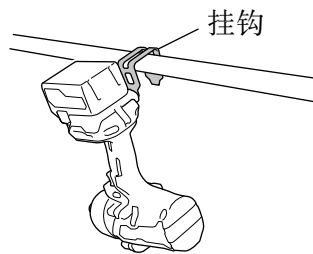

图 16

(2) 重新装上挂钩并拧紧螺丝。

将挂钩牢固安装到电动工具的凹槽中，拧紧螺丝固定挂钩。(图 17)

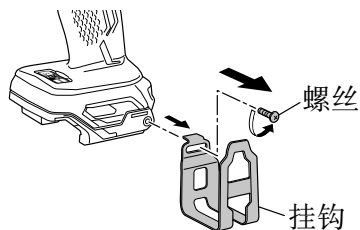

图 17

5. 剩余电池电量指示灯

可以按下剩余电池电量指示灯开关点亮指示灯，查看电池的剩余电量。(图 18, 表 4) 按住剩余电池电量指示灯开关约 3 秒后，指示灯将熄灭。

环境温度和电池状态可能会对剩余电池电量产生轻微的影响，因此，建议您仅将指示灯作为参考。

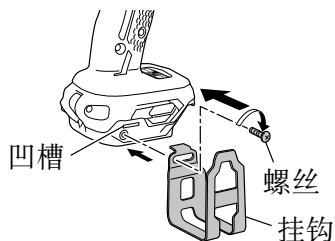
此外，电动工具或充电器上的剩余电池电量指示灯可能有所不同。



表 4

指示灯状态	电池剩余电量
	点亮； 电池剩余电量超过 75%。
	点亮； 电池剩余电量为 50%—75%。
	点亮； 电池剩余电量为 25%—50%。
	点亮； 电池剩余电量不到 25%。
	闪烁； 电池剩余电量即将耗尽。请尽快对电池进行充电。
	闪烁； 因高温暂停输出从电动工具中取下电池，让电池完全冷却。
	闪烁； 因失败或故障暂停输出。电池可能出现故障，请与经销商联系。

环境温度和电池特性不同，则所显示的电池剩余电量也会有些许不同，以上内容仅供参考。

注：

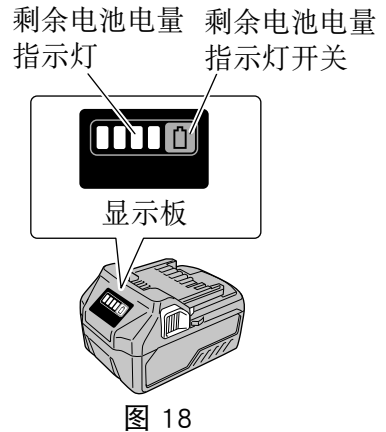
请勿强烈撞击或破坏开关面板。否则可能会导致故障。

6. LED 灯的使用方法

拔出开关后，LED 灯将自动点亮工具尖头部分。(图 19)

开关松开后，LED 灯将会自动关闭 10 秒钟。



图 19

注意！

○ 请不要直视灯光，避免眼睛直接受灯光照射。

如果眼睛持续受灯光照射，会伤害眼睛。

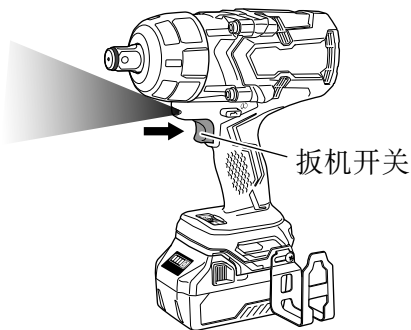
○ 用软布仔细擦拭附着在 LED 灯镜片上的灰尘或污垢，小心不要划伤镜片。

如果划伤 LED 灯的镜片，可能会导致亮度减弱。

7. 旋紧模式选择功能

注意！

○ 请勿撞击或损坏开关面板。

○ 请在松开扳机开关时选择旋紧模式。否则可能导致故障。

可根据作业类型，通过组合使用高 / 低速模式选择开关和自停模式选择开关来调整旋紧扭矩。(图 20)

自停模式
选择开关

高 / 低速模式
选择开关



图 20

(1) 高 / 低模式选择器开关 (图 21)

每次按高 / 低模式选择器开关时，收紧模式在四个不同的旋转速度中进行切换。



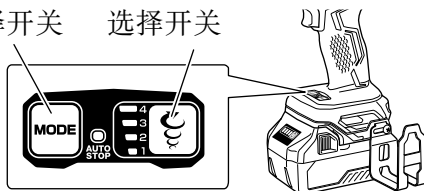



图 21

表 5

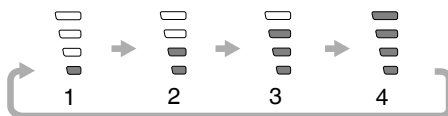
高 / 低模式设置

高 / 低模式	1	2	3	4
指示灯				
最大卸载速度 (/min)	600	900	1200	1500
自动停止 / 自动慢速模式	关			
使用	用于需要精细调整的作业。		用于需要压制力量的作业。	用于需要力量和速度的作业。

(2) 自动停止模式选择器开关 (图 22)

按自动停止模式选择器开关切换模式。

自动停止模式选择器开关

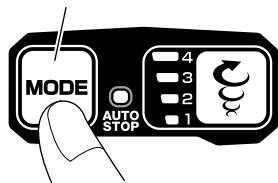

前进：自动停止模式
后退：自动慢速模式



图 22

(3) 自动停止模式 (图 23, 表 6)

在超过预设时间后自动停止。

推钮至前进 (“R”) 位置, 然后按自动停止模式选择器开关以选择设置。

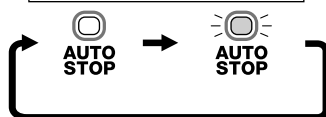

图 23

表 6

自动停止模式设置

	自动停止模式			
	1	2	3	4
指示灯				
最大卸载速度 (/min)	600	900	1200	1500
自动停止时间	在撞击开始后 1.2 秒内停止。			
使用	钢框暂时收紧等	卡车轮胎螺母或管道暂时收紧等	重型机械或桥梁暂时收紧等	

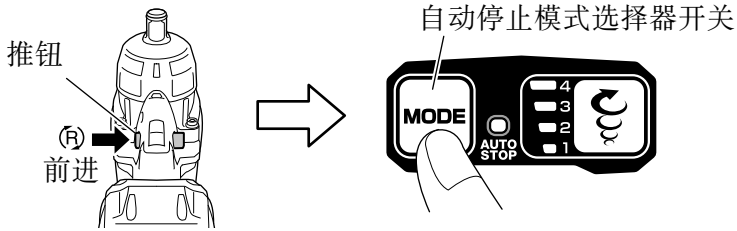
(4) 自动慢速模式 (图 24, 表 7)

在预设时间停止及 / 或将速度自动更改为预设速度。

推钮至后退 (“L”) 位置, 然后按自动停止模式选择器开关以选择设置。



图 24

表 7

自动慢速模式设置

		自动慢速模式			
		1	2	3	4
指示灯					
自动慢速操作	开关移位: 最大	在检测到螺栓松动后暂停。 在停止 0.5 秒后重新开始, 然后根据拉动开关的距离以 60–350 /min 速度旋转。 * 重新开始后旋转不会停止。			
	开关移位: 半程	根据开始后拉动开关的距离, 旋转速度以如下方式降低。 * 旋转不停止。			
使用		60–330 /min	60–500 /min	60–660 /min	60–830 /min
		用于松动螺栓或螺母时的作业。			

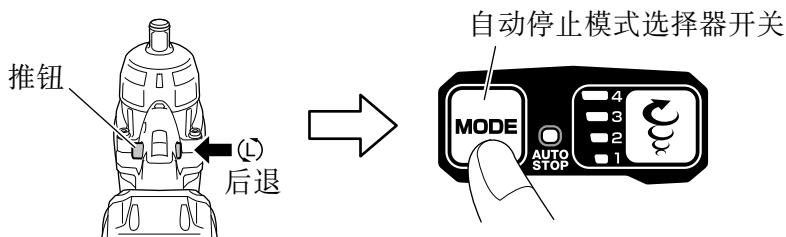
此功能帮助防止螺母在松动时掉落。

注:

- 取决于如螺栓或螺母尺寸、所使用插座及收紧范围等因素, 如果在电动工具运行期间螺母从螺纹中脱落, 则存在螺母意外掉落的风险。
- 请根据螺栓和需钻钉的材料选择适当的模式。请拧紧一些测试用螺栓, 相应地调整模式设定。
- 仅在扳手已安装电池且已拉动过一次扳机开关后, 才可以对旋紧模式选择开关进行设定。

操作上的注意事项

1. 连续作业后须让电动工具休息片刻

电动工具内装有温度保护电路以保护电机。长时间连续作业可能会导致机器温度升高、触发温度保护电路并自动停止作业。在此情况下，请在电动工具冷却后再继续使用。

如果工具超过负荷，电机可能停止。在这种情况下，请松开工具的开关，试着消除超过负荷的原因。

请在长时间连续作业后或更换电池后，使机器静止 15 分钟。如果在更换电池后立刻开始作业，马达和开关等的温度将会升高，结果导致烧毁。

注：

锤壳在连续作业后可能温度升高，请勿触碰。

2. 关于转速控制开关的注意事项

此开关带有可无级改变转速的内置电路。因此，当轻拉启动开关（低速转动）并在连续旋紧螺丝中停止马达转动时，电路部分的元件可能会因过热而损坏。

3. 以适于受冲击螺栓的旋紧扭矩进行操作

螺栓和螺母最适宜的旋紧扭矩因螺栓或螺母的材料和尺寸而有所不同。对小螺栓使用过大的旋紧扭矩会扭曲或损坏螺栓。旋紧扭矩的增加与操作时间成正比。请使用正确的螺栓操作时间。

4. 握住工具

请用双手牢牢握住工具。在此情况下，请与螺栓成直线地握住工具。

无需用力推工具，用足以抵消冲击力的力握住工具。

5. 确定旋紧扭矩

下列因素会造成旋紧扭矩的下降。因此请在工作前用手工扭矩扳手来确定上紧螺栓所需的实际旋紧扭矩。影响旋紧扭矩的因素如下。

(1) 电压

达到放电极限时，电压降低，旋紧扭矩也减少。

(2) 操作时间

操作时间增加时旋紧扭矩也增加。但是，即使工具驱动很长的一段时间，旋紧扭矩也不会增大到超过某个特定值。

(3) 螺栓的直径

旋紧扭矩根据螺栓的直径变化。一般来说较大直径的螺栓需要较大的旋紧扭矩。

(4) 旋紧的状态

即使使用相同尺寸螺纹的螺栓，旋紧扭矩根据螺栓的扭矩比率、等级和长度也各不相同。旋紧扭矩还因螺栓所要上紧的加工件的表面状况而有所不同。螺栓和螺母一起转动时，扭矩会大大减少。

(5) 使用选购部件

使用接杆、万向接头或长套筒时拧紧扭矩略小一些。

中文

(6) 套筒间隙

磨损或变形的六角或方孔套筒不能在螺母或铁砧之间提供适当的固定拧紧力，从而导致拧紧扭矩的损失。

使用不适合于螺栓的套筒会导致拧紧扭矩不足。

(7) 拧紧扭矩因电池充电程度而异。

USB 设备的充电方法

警告！

- 使用之前请检查 USB 连接线缆是否有破损或损坏。
使用有破损或损坏的 USB 线缆可能会导致冒烟或着火。
- 不使用产品时，请用橡胶盖封好 USB 端口。
USB 端口中落入灰尘等可能会导致冒烟或着火。

注：

- USB 充电过程中，可能会有偶尔暂停。
- USB 设备未充电时，请将充电器上拔下 USB 设备。
否则不仅会减少 USB 设备的电池寿命，还会导致意外事故。
- 根据设备类型，可能无法对部分 USB 设备进行充电。

(1) 选择充电方式

根据所选的充电方式，将电池插入充电器或连接电源线插入插座。

- 将 USB 设备插入插座进行充电
(图 25-a)。
- 将 USB 设备和电池插入插座进行充电。
(图 25-b)



图 25

(2) 连接 USB 线缆。(图 26)

拔下橡胶盖并将市售的 USB 线缆（匹配充电的设备）紧紧插入 USB 端口。

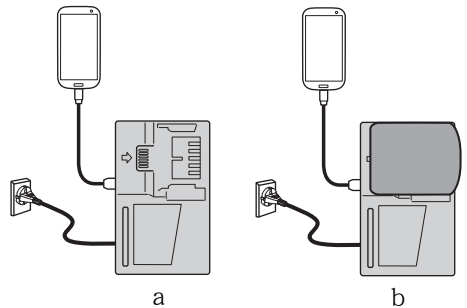

图 26

(3) 充电完成时

- 检查 USB 设备以检验充电状态。
- 从插座中拔下电源线。(图 27)
- 用橡胶盖盖住 USB 端口。

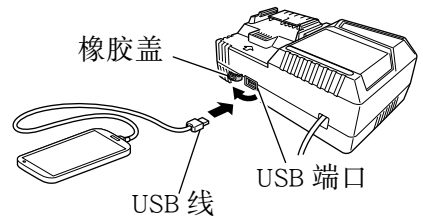

图 27

维护和检查

警告！

在进行任何检查或维护前，请务必将开关设为关位置，并拉出电池。

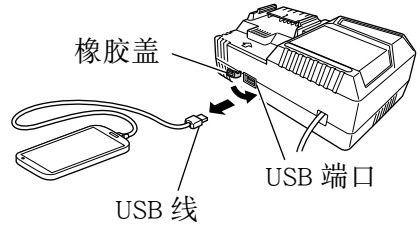
1. 检查套筒

磨损或变形的六角或方孔套筒不能在螺母或铁砧之间提供适当的固定拧紧力，从而导致拧紧扭矩的损失。

请定期检查套筒孔的磨损程度，如有需要换成新的。

2. 检查安装螺钉

要经常检查安装螺钉是否紧固妥善。若发现螺钉松了，应立即重新扭紧，否则会导致严重的事故。

3. 电动机的维护

电动机绕线是电动工具的“心脏部”应仔细检查有无损伤，是否被油液或水沾湿。

4. 检查端子（工具和电池）

确保端子上没有堆积削屑和灰尘。

在操作前、操作时和操作后需要时常检查。

注意！

请清除端子上的削屑或灰尘。

否则可能导致故障。

5. 清理外部

冲击扳手沾污时，用干软布或沾肥皂水的布擦拭。切勿使用氯溶液、汽油或稀释剂，以免塑胶部分溶化。

6. 收藏

将电动工具及电池存放在温度低于 40℃、且儿童无法触及的位置。

中文

注：

存放锂离子电池

在存放前请确保电池已完全充电。

电池在低电量的状态下长时间存放(3个月或更长)，可能会导致电池性能劣化，使用时间明显减少或无法进行充电。

但是，即使是使用时间明显减少的电池，通过反复充电和使用2~5次，有时也可恢复使用时间。

若反复充电和使用后电池的使用时间仍非常短，请认作为电池已达到了使用寿命并更换新的电池。

注意！

在操作和维修电动工具时，必须遵守贵国制定的安全的有关规则和标准。

关于 HiKOKI 牌无线电动工具的重要通知：

请确保始终使用我们指定的正版电池。如果使用我们指定以外的电池，或对电池进行拆卸和改动（例如拆卸和更换电池组件或其他内部部件），那么我们无法保证我们无线电动工具的安全性和使用性能。

故障排除

如果工具操作不正常，请使用下表中的检查步骤。如果未能解决问题，请向经销商或 HIKOKI 公司授权服务中心咨询。

现象	可能的原因	解决办法
工具无法运行	没有剩余电池电量	为电池充电
工具突然停止	工具过度负重	避免因负载过重而引发的问题。
	电池过热。	让电池冷却。
	按下扳机开关 5 分钟或更久。	这种情况不属于故障。电机已自动停止以防止工具发生故障。
工具套筒 - 无法安装 - 掉落 - 无法拆除	安装部分的形状不匹配	确保使用适当的四角起子尺寸的套筒。 WR36DF: 19 mm WR36DG: 12.7 mm
无法拔出开关	推钮归位在半程。	根据想要的旋转方向将推钮紧压到底
拉动扳机开关时，将发出异常尖锐的噪声。	请轻微拉动扳机开关。	这种情况不属于故障。如果充分拉动扳机开关，则不会发生此种情况。
无法安装电池	请尝试安装该工具指定的其他正版电池。	请安装多电压式电池。

选择附件

根据特定作业选择适合的附件。
有关详细信息请联系 HiKOKI 授权服务中心。

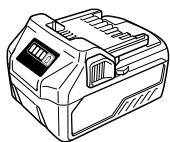

BSL36A18
电池

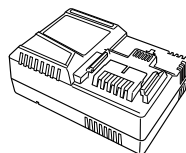

UC18YSL3
(14.4 V - 18 V)
充电器

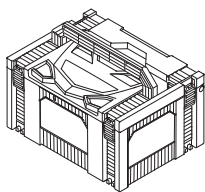

产品编号：337108
外壳（可堆叠）

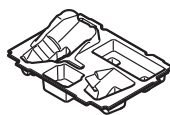

产品编号：375578

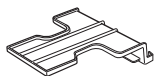

产品编号：329897
电池盖

CONTENTS

GENERAL POWER TOOL SAFETY WARNINGS	31
CORDLESS IMPACT WRENCH SAFETY WARNINGS	34
CAUTION ON LITHIUM-ION BATTERY	36
REGARDING LITHIUM-ION BATTERY TRANSPORTATION	38
USB DEVICE CONNECTION PRECAUTIONS	38
PRECAUTIONS REGARDING THE DUST-RESISTANCE AND WATER-PROOFING FUNCTIONS.....	39
SYMBOLS	39
NAME OF PARTS.....	40
SPECIFICATIONS	41
STANDARD ACCESSORIES	42
APPLICATIONS.....	42
BATTERY REMOVAL/INSTALLATION.....	43
CHARGING	43
PRIOR TO OPERATION.....	46
HOW TO USE.....	48
OPERATIONAL CAUTIONS.....	55
HOW TO RECHARGE USB DEVICE	56
MAINTENANCE AND INSPECTION	57
TROUBLESHOOTING.....	59
SELECTING ACCESSORIES.....	60

GENERAL POWER TOOL SAFETY WARNINGS

WARNING

Read all safety warnings, instructions, illustrations and specifications provided with this power tool.

Failure to follow all instructions listed below may result in electric shock, fire and/or serious injury.

Save all warnings and instructions for future reference.

The term “power tool” in the warnings refers to your mains-operated (corded) power tool or battery-operated (cordless) power tool.

- 1) **Work area safety**
 - a) **Keep work area clean and well lit.**
Cluttered or dark areas invite accidents.
 - b) **Do not operate power tools in explosive atmospheres, such as in the presence of flammable liquids, gases or dust.**
Power tools create sparks which may ignite the dust or fumes.
 - c) **Keep children and bystanders away while operating a power tool.**
Distractions can cause you to lose control.

English

2) Electrical safety

- a) **Power tool plugs must match the outlet.**
Never modify the plug in any way.
Do not use any adapter plugs with earthed (grounded) power tools.
Unmodified plugs and matching outlets will reduce risk of electric shock.
- b) **Avoid body contact with earthed or grounded surfaces, such as pipes, radiators, ranges and refrigerators.**
There is an increased risk of electric shock if your body is earthed or grounded.
- c) **Do not expose power tools to rain or wet conditions.**
Water entering a power tool will increase the risk of electric shock.
- d) **Do not abuse the cord. Never use the cord for carrying, pulling or unplugging the power tool.**
Keep cord away from heat, oil, sharp edges or moving parts.
Damaged or entangled cords increase the risk of electric shock.
- e) **When operating a power tool outdoors, use an extension cord suitable for outdoor use.**
Use of a cord suitable for outdoor use reduces the risk of electric shock.
- f) **If operating a power tool in a damp location is unavoidable, use a residual current device (RCD) protected supply.**
Use of an RCD reduces the risk of electric shock.

3) Personal safety

- a) **Stay alert, watch what you are doing and use common sense when operating a power tool.**
Do not use a power tool while you are tired or under the influence of drugs, alcohol or medication.
A moment of inattention while operating power tools may result in serious personal injury.
- b) **Use personal protective equipment. Always wear eye protection.**
Protective equipment such as a dust mask, non-skid safety shoes, hard hat or hearing protection used for appropriate conditions will reduce personal injuries.
- c) **Prevent unintentional starting. Ensure the switch is in the off-position before connecting to power source and/or battery pack, picking up or carrying the tool.**
Carrying power tools with your finger on the switch or energising power tools that have the switch on invites accidents.
- d) **Remove any adjusting key or wrench before turning the power tool on.**
A wrench or a key left attached to a rotating part of the power tool may result in personal injury.
- e) **Do not overreach. Keep proper footing and balance at all times.**
This enables better control of the power tool in unexpected situations.
- f) **Dress properly. Do not wear loose clothing or jewellery. Keep your hair, clothing and gloves away from moving parts.**
Loose clothes, jewellery or long hair can be caught in moving parts.

- g) **If devices are provided for the connection of dust extraction and collection facilities, ensure these are connected and properly used.**
Use of dust collection can reduce dust-related hazards.
- h) **Do not let familiarity gained from frequent use of tools allow you to become complacent and ignore tool safety principles.**
A careless action can cause severe injury within a fraction of a second.

4) Power tool use and care

- a) **Do not force the power tool. Use the correct power tool for your application.**
The correct power tool will do the job better and safer at the rate for which it was designed.
- b) **Do not use the power tool if the switch does not turn it on and off.**
Any power tool that cannot be controlled with the switch is dangerous and must be repaired.
- c) **Disconnect the plug from the power source and/or remove the battery pack, if detachable, from the power tool before making any adjustments, changing accessories, or storing power tools.**
Such preventive safety measures reduce the risk of starting the power tool accidentally.
- d) **Store idle power tools out of the reach of children and do not allow persons unfamiliar with the power tool or these instructions to operate the power tool.**
Power tools are dangerous in the hands of untrained users.
- e) **Maintain power tools and accessories. Check for misalignment or binding of moving parts, breakage of parts and any other condition that may affect the power tool's operation.**
If damaged, have the power tool repaired before use.
Many accidents are caused by poorly maintained power tools.
- f) **Keep cutting tools sharp and clean.**
Properly maintained cutting tools with sharp cutting edges are less likely to bind and are easier to control.
- g) **Use the power tool, accessories and tool bits etc. in accordance with these instructions, taking into account the working conditions and the work to be performed.**
Use of the power tool for operations different from those intended could result in a hazardous situation.
- h) **Keep handles and grasping surfaces dry, clean and free from oil and grease.**
Slippery handles and grasping surfaces do not allow for safe handling and control of the tool in unexpected situations.

5) Battery tool use and care

- a) **Recharge only with the charger specified by the manufacturer.**
A charger that is suitable for one type of battery pack may create a risk of fire when used with another battery pack.
- b) **Use power tools only with specifically designated battery packs.**
Use of any other battery packs may create a risk of injury and fire.

English

- c) **When battery pack is not in use, keep it away from other metal objects, like paper clips, coins, keys, nails, screws or other small metal objects, that can make a connection from one terminal to another.**
Shorting the battery terminals together may cause burns or a fire.
- d) **Under abusive conditions, liquid may be ejected from the battery; avoid contact. If contact accidentally occurs, flush with water. If liquid contacts eyes, additionally seek medical help.**
Liquid ejected from the battery may cause irritation or burns.
- e) **Do not use a battery pack or tool that is damaged or modified.**
Damaged or modified batteries may exhibit unpredictable behaviour resulting in fire, explosion or risk of injury.
- f) **Do not expose a battery pack or tool to fire or excessive temperature.**
Exposure to fire or temperature above 130 °C may cause explosion.
- g) **Follow all charging instructions and do not charge the battery pack or tool outside the temperature range specified in the instructions.**
Charging improperly or at temperatures outside the specified range may damage the battery and increase the risk of fire.

6) Service

- a) **Have your power tool serviced by a qualified repair person using only identical replacement parts.**
This will ensure that the safety of the power tool is maintained.
- b) **Never service damaged battery packs.**
Service of battery packs should only be performed by the manufacturer or authorized service providers.

CAUTION

Keep children and infirm persons away.

When not in use, tools should be stored out of reach of children and infirm persons.

CORDLESS IMPACT WRENCH SAFETY WARNINGS

1. **Hold power tool by insulated gripping surfaces, when performing an operation where the fastener may contact hidden wiring. Fasteners contacting a “live” wire may make exposed metal parts of the power tool “live” and could give the operator an electric shock.**
2. **This is a portable tool for tightening and loosening bolts and nuts. Use it only for these operations.**
3. **Use the earplugs if using for a long time.**

4. **Make sure to securely hold the tool during operation. Failure to do so can result in accidents or injuries. (Fig. 1)**
5. **Check that the socket is not cracked or broken. Broken or cracked sockets are dangerous. Check the socket before using it.**
6. **Secure the socket with the socket pin and the ring. If the socket pin or ring securing the socket is damaged, the socket may come off from the impact wrench, which is quite dangerous. Do not use socket pins or rings that are deformed, worn out, cracked, or in any other way damaged. Always make sure to install the socket pin and ring in the correct position.**
7. **Check the tightening torque.**
 The appropriate torque for tightening a bolt depends on the material the bolt is made of, its dimensions, grade, etc.
 Also, the tightening torque generated by this impact wrench depends on the materials and dimensions of the bolt, how long the impact wrench is applied for the way in which the socket is installed, etc.
 Also the torque when the battery has just been charged and when it is about to run out are slightly different. Use a torque wrench to check that the bolt has been tightened with the appropriate torque.
8. **Stop the impact wrench before switching the direction of rotation. Always release the switch and wait for impact wrench to stop before switching the direction of rotation.**
9. **Never touch the turning part.**
 Do not allow the turning socket section to get near your hands or any other part of your body. You could be cut or caught in the socket. Also, be careful not to touch the socket after using continuously it for a long time. It gets quite hot and could burn you.
10. **Never let the impact wrench turn without a load when using the universal joint.**
 If the socket turns without being connected to a load, the universal joint causes the socket to turn wildly. You could get hurt or the movement of the socket could shake the impact wrench so much as to make you drop it.
11. **If you notice that the unit is generating unusually high temperatures, operating poorly, or making abnormal noises, immediately stop using and shut off the power switch. Request an inspection and repair from the dealer where you purchased the unit or a HiKOKI Authorized Service Center.**
 Continuing to use while operating abnormally might cause injuries.
12. **If the unit is mistakenly dropped or strikes another object, make a thorough check of the unit for cracks, breakage or deformation, etc.**
 Injuries might occur if the unit has cracks, breakage or deformation.
13. **When working at elevated locations, clear the area of other people and aware of conditions below you.**

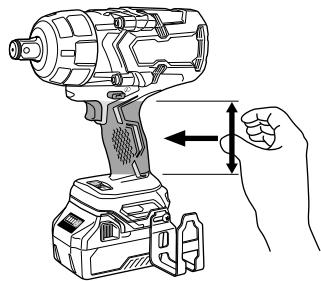

Fig. 1

English

14. Always charge the battery at a temperature of 0–40°C.
A temperature of less than 0°C will result in over charging which is dangerous.
The battery cannot be charged at a temperature greater than 40°C.
The most suitable temperature for charging is that of 20–25°C.
15. Do not use the charger continuously.
When one charging is completed, leave the charger for about 15 minutes before the next charging of battery.
16. Do not allow foreign matter to enter the hole for connecting the battery.
17. Never disassemble the battery and charger.
18. Never short-circuit the battery.
Short-circuiting the battery will cause a great electric current and overheat. It results in burn or damage to the battery.
19. Do not dispose of the battery in fire.
If the battery burnt, it may explode.
20. Do not insert object into the air ventilation slots of the charger.
Inserting metal objects or inflammables into the charger air ventilation slots will result in electrical shock hazard or damaged charger.
21. Bring the battery to the shop from which it was purchased as soon as the post-charging battery life becomes too short for practical use. Do not dispose of the exhausted battery.
22. Using an exhausted battery will damage the charger.
23. Make sure that the battery is installed firmly. If it is at all loose it could come off and cause an accident.
24. Do not use the product if the tool or the battery terminals (battery mount) are deformed.
Installing the battery could cause a short circuit that could result in smoke emission or ignition.
25. Keep the tool's terminals (battery mount) free of swarf and dust.
 - Prior to use, make sure that swarf and dust have not collected in the area of the terminals.
 - During use, try to avoid swarf or dust on the tool from falling on the battery.
 - When suspending operation or after use, do not leave the tool in an area where it may be exposed to falling swarf or dust.
Doing so could cause a short circuit that could result in smoke emission or ignition.
26. Always use the tool and battery at temperatures between -5°C and 40°C.

CAUTION ON LITHIUM-ION BATTERY

To extend the lifetime, the lithium-ion battery equips with the protection function to stop the output.

In the cases of 1 to 3 described below, when using this product, even if you are pulling the switch, the motor may stop. This is not the trouble but the result of protection function.

1. When the battery power remaining runs out, the motor stops. In such case, charge it up immediately.
2. If the tool is overloaded, the motor may stop. In this case, release the switch of tool and eliminate causes of overloading. After that, you can use it again.
3. If the battery is overheated under overload work, the battery power may stop. In this case, stop using the battery and let the battery cool. After that, you can use it again.

Furthermore, please heed the following warning and caution.

WARNING

In order to prevent any battery leakage, heat generation, smoke emission, explosion and ignition beforehand, please be sure to heed the following precautions.

1. Make sure that swarf and dust do not collect on the battery.
 - During work make sure that swarf and dust do not fall on the battery.
 - Make sure that any swarf and dust falling on the power tool during work do not collect on the battery.
 - Do not store an unused battery in a location exposed to swarf and dust.
 - Before storing a battery, remove any swarf and dust that may adhere to it and do not store it together with metal parts (screws, nails, etc.).
2. Do not pierce battery with a sharp object such as a nail, strike with a hammer, step on, throw or subject the battery to severe physical shock.
3. Do not use an apparently damaged or deformed battery.
4. Do not use the battery for a purpose other than those specified.
5. If the battery charging fails to complete even when a specified recharging time has elapsed, immediately stop further recharging.
6. Do not put or subject the battery to high temperatures or high pressure such as into a microwave oven, dryer, or high pressure container.
7. Keep away from fire immediately when leakage or foul odor are detected.
8. Do not use in a location where strong static electricity generates.
9. If there is battery leakage, foul odor, heat generated, discolored or deformed, or in any way appears abnormal during use, recharging or storage, immediately remove it from the equipment or battery charger, and stop use.
10. Do not immerse the battery or allow any fluids to flow inside. Conductive liquid ingress, such as water, can cause damage resulting in fire or explosion. Store your battery in a cool, dry place, away from combustible and flammable items. Corrosive gas atmospheres must be avoided.

CAUTION

1. If liquid leaking from the battery gets into your eyes, do not rub your eyes and wash them well with fresh clean water such as tap water and contact a doctor immediately.
If left untreated, the liquid may cause eye-problems.
2. If liquid leaks onto your skin or clothes, wash well with clean water such as tap water immediately.
There is a possibility that this can cause skin irritation.

English

3. If you find rust, foul odor, overheating, discolor, deformation, and/or other irregularities when using the battery for the first time, do not use and return it to your supplier or vendor.

WARNING

If a conductive foreign matter enters in the terminal of lithium ion battery, the battery may be shorted, causing fire. When storing the lithium ion battery, obey surely the rules of following contents.

- Do not place conductive debris, nail and wires such as iron wire and copper wire in the storage case.
- Either install the battery in the power tool or store by securely pressing into the battery cover until the ventilation holes are concealed to prevent short-circuits (See Fig. 2).

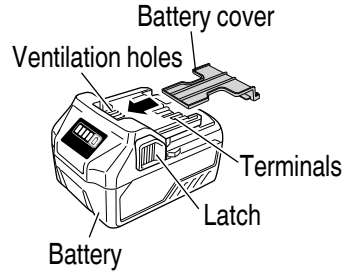

Fig. 2

REGARDING LITHIUM-ION BATTERY TRANSPORTATION

When transporting a lithium-ion battery, please observe the following precautions.

WARNING

Notify the transporting company that a package contains a lithium-ion battery, inform the company of its power output and follow the instructions of the transportation company when arranging transport.

- Lithium-ion batteries that exceed a power output of 100 Wh are considered to be in the freight classification of Dangerous Goods and will require special application procedures.
- For transportation abroad, you must comply with international law and the rules and regulations of the destination country.

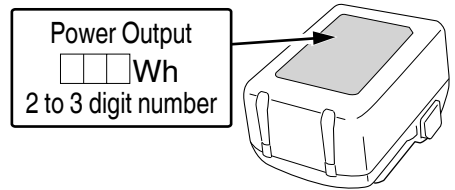

Fig. 3

USB DEVICE CONNECTION PRECAUTIONS

When an unexpected problem occurs, the data in a USB device connected to this product may be corrupted or lost. Always make sure to back up any data contained in the USB device prior to use with this product.



Please be aware that our company accepts absolutely no responsibility for any data stored in a USB device that is corrupted or lost, nor for any damage that may occur to a connected device.

PRECAUTIONS REGARDING THE DUST-RESISTANCE AND WATER-PROOFING FUNCTIONS

This product conforms to IP56 protection class ratings (dust-resistance and water-proofing) for electrical equipment as stipulated by the international IEC regulations. (Only the main unit conforms to the IP56 protection class ratings when equipped with a battery.)

[Descriptions of IP Codes]

IP56



-  Protection rating for water penetration
 Must be no adverse effects on the equipment when sprayed with powerful jets of water from all directions (water-proofed).
 (100 L of water per minute sprayed for approximately three minutes from a distance of approximately three meters with the use of a spray nozzle with a diameter of 12.5 mm.)
-  Protection rating for external assault by solid objects
 Dust that may cause adverse effects on the equipment must not be able to enter (dust-resistance).
 (The equipment to be left non-operable in a test chamber in which particles of talcum powder with a diameter of less than 75 μm are floating in the air with the use of an agitation pump at a rate of 2 kg per cubic meter for eight hours.)

The equipment has been designed to withstand the effects of dust and water, but there is no guarantee that it will not malfunction. Do not use or leave the equipment in locations where it is subject to excessive amounts of dust, or in locations where it is submerged in water or subject to rainwater.

SYMBOLS

WARNING

The following show symbols used for the machine. Be sure that you understand their meaning before use.

	To reduce the risk of injury, user must read instruction manual.	n_0	No-load speed
	Direct current	/min	Oscillation per minute
V	Rated voltage		Warning

NAME OF PARTS

1. POWER TOOL

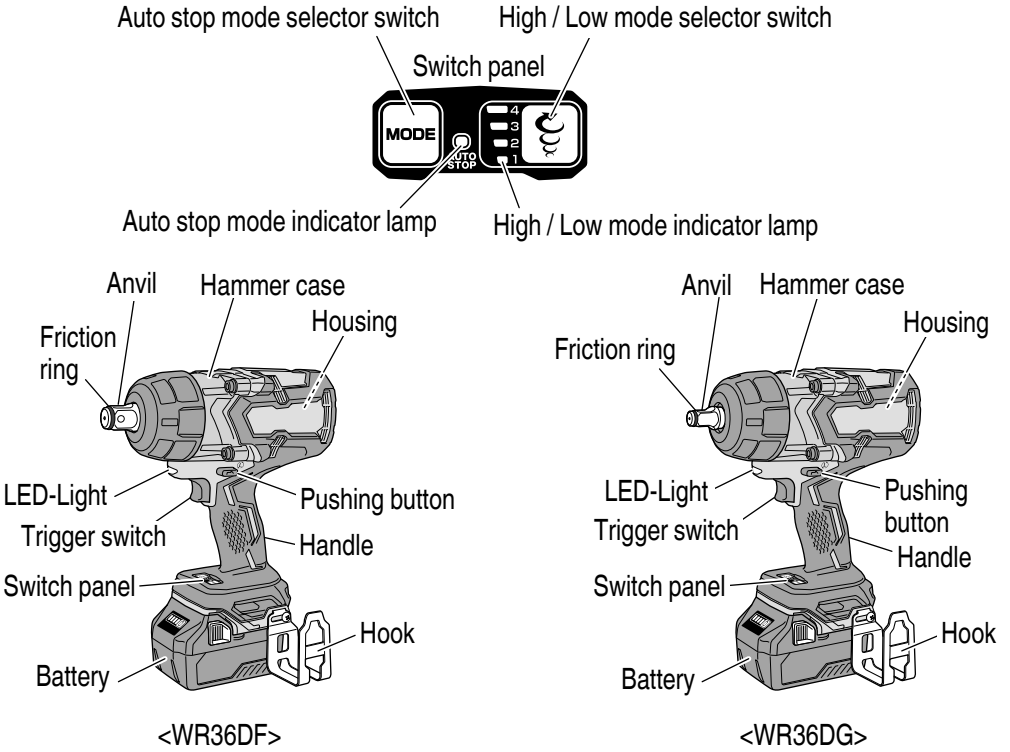

Fig. 4

2. Battery

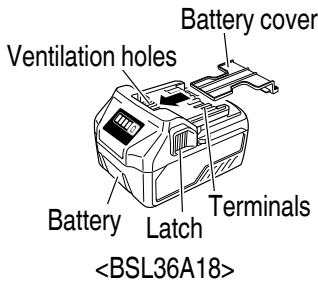

Fig. 5

3. Battery Charger

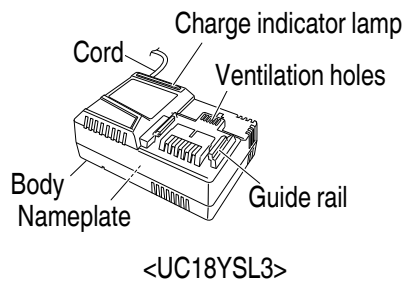

Fig. 6

SPECIFICATIONS

POWER TOOL

Model		WR36DF	WR36DG
Voltage		36 V	
No-load speed	Mode 4	0–1500 /min	
	Mode 3	0–1200 /min	
	Mode 2	0–900 /min	
	Mode 1	0–600 /min	
Capacity	Ordinary bolt	M12–M36	M12–M33
	High tension bolt	M10–M27	M10–M24
Tightening torque		Maximum 1900 N·m	Maximum 1400 N·m
Square Drive size		19 mm	12.7 mm
Battery*		BSL36A18: Li-ion 36 V / 18 V (2.5 Ah / 5.0 Ah 10 cells)	
Weight		3.9 kg (BSL36A18: attached)	

* Existing batteries (BSL3660/3626/3620, BSL18xx and BSL14xx series) cannot be used with this tool.



CHARGER

Model	UC18YSL3
Charging voltage	14.4–18 V
Weight	0.6 kg

STANDARD ACCESSORIES

In addition to the main unit (1 unit), the package contains the accessories listed in the below.

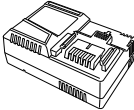
Table 1

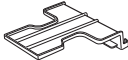
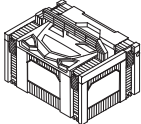
		WR36DF, WR36DG	
		2XCP	NNP
Charger (UC18YSL3)		1	—
Battery (BSL36A18)		2	—
Battery cover		1	—
Case (Stackable)		1	1

The charger and battery supplied are different depending on the set specification.

APPLICATIONS

Tightening and loosening of all types of bolts and nuts, used for securing structural items.

BATTERY REMOVAL/INSTALLATION

- Battery removal**
Hold the handle tightly and push the battery latches to remove the battery (see **Fig. 7**).

CAUTION

Never short-circuit the battery.

- Battery installation**
Insert the battery while observing its polarities (see **Fig. 7**).

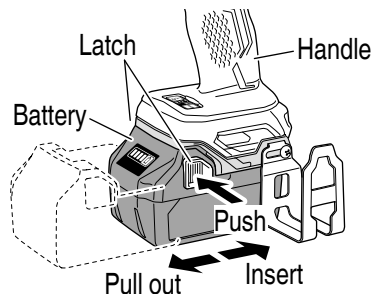

Fig. 7

CHARGING

Before using the power tool, charge the battery as follows.

- Connect the charger's power cord to the receptacle.**

When connecting the plug of the charger to a receptacle, the charge indicator lamp will blink in red (At 1- second intervals).

- Insert the battery into the charger.**

Firmly insert the battery into the charger as shown in **Fig. 8**.

- Charging**

When inserting a battery in the charger, the charge indicator lamp will blink in blue.

When the battery becomes fully recharged, the charge indicator lamp will light up in green.
(See **Table 2 on page 44**)

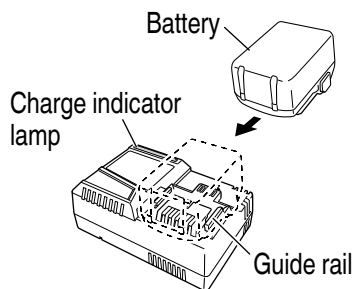







Fig. 8

English

(1) Charge indicator lamp indication

The indications of the charge indicator lamp will be as shown in **Table 2**, according to the condition of the charger or the rechargeable battery.

Table 2

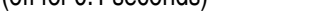
Indications of the charge indicator lamp				
Charge indicator lamp (RED / BLUE / GREEN / PURPLE)	Before charging	Blinks (RED)	Lights for 0.5 seconds. Does not light for 0.5 seconds. (off for 0.5 seconds) 	Plugged into power source *1
	While charging	Blinks (BLUE)	Lights for 0.5 seconds. Does not light for 1 second. (off for 1 second) 	Battery capacity at less than 50%
		Blinks (BLUE)	Lights for 1 second. Does not light for 0.5 seconds. (off for 0.5 seconds) 	Battery capacity at less than 80%
		Lights (BLUE)	Lights continuously 	Battery capacity at more than 80%
	Charging complete	Lights (GREEN)	Lights continuously  (Continuous buzzer sound: about 6 seconds)	/
	Overheat standby	Blinks (RED)	Lights for 0.3 seconds. Does not light for 0.3 seconds. (off for 0.3 seconds) 	Battery overheated. Unable to charge. (Charging will commence when battery cools) *2
	Charging impossible	Flickers (PURPLE)	Lights for 0.1 seconds. Does not light for 0.1 seconds. (off for 0.1 seconds)  (Intermittent buzzer sound: about 2 seconds)	Malfunction in the battery or the charger *3

*1 If the red lamp continues to blink even after the charger has been attached, check to confirm that the battery has been fully inserted.

*2 Although charging will start once the battery has cooled down even when left in situ, the best practice is to remove the battery and allow it to cool down in a shaded, well-ventilated location before charging.

*3

- Fully insert the battery.
 - Check to confirm that no foreign matter is stuck to the battery mount or terminals.
- <If charging takes a long time>
- Charging will take longer at extremely low ambient temperatures. Charge the battery in a warm location (such as indoors).
 - Do not block the air vent. Otherwise the interior will overheat, reducing the charger's performance.
 - If the cooling fan is not operating, contact a HiKOKI Authorized Service Center for repairs.
- (2) Regarding the temperatures and charging time of the rechargeable battery
The temperatures and charging time will become as shown in **Table 3**.

Table 3

Battery		Charger	UC18YSL3	
Type of battery			Li-ion	
Charging voltage			14.4–18 V	
Temperatures at which the battery can be recharged			0°C–50°C	
Charging time for battery capacity, approx. (At 20°C)		1.5 Ah	15 min	
		2.0 Ah	20 min	
		2.5 Ah	25 min	
		3.0 Ah	20 min (BSL1430C, BSL1830C: 30 min)	
		4.0 Ah	26 min (BSL1840M: 40 min)	
		5.0 Ah	32 min	
		6.0 Ah	38 min	
		8.0 Ah	52 min	
	Multi volt battery		1.5 Ah (× 2 unit)	20 min
			2.5 Ah (× 2 unit)	32 min
		4.0 Ah (× 2 unit)	52 min	
Number of battery cells			4–10	
Charging voltage for USB			5 V	
Charging current for USB			2 A	
Weight			0.6 kg	

NOTE

The recharging time may vary according to the ambient temperature and power source voltage.

4. Disconnect the charger's power cord from the receptacle.

English

5. Hold the charger firmly and pull out the battery.

NOTE

Be sure to pull out the battery from the charger after use, and then keep it.

Regarding electric discharge in case of new batteries, etc.

As the internal chemical substance of new batteries and batteries that have not been used for an extended period is not activated, the electric discharge might be low when using them the first and second time. This is a temporary phenomenon, and normal time required for recharging will be restored by recharging the batteries 2 – 3 times.

How to make the batteries perform longer.

- (1) Recharge the batteries before they become completely exhausted.
When you feel that the power of the tool becomes weaker, stop using the tool and recharge its battery. If you continue to use the tool and exhaust the electric current, the battery may be damaged and its life will become shorter.
- (2) Avoid recharging at high temperatures.
A rechargeable battery will be hot immediately after use. If such a battery is recharged immediately after use, its internal chemical substance will deteriorate, and the battery life will be shortened. Leave the battery and recharge it after it has cooled for a while.

CAUTION

- **If the battery is charged while it is heated because it has been left for a long time in a location subject to direct sunlight or because the battery has just been used, the charge indicator lamp of the charger lights for 0.3 seconds, does not light for 0.3 seconds (off for 0.3 seconds). In such a case, first let the battery cool, then start charging.**
- **When the charge indicator lamp flickers (at 0.2-second intervals), check for and take out any foreign objects in the charger's battery connector. If there are no foreign objects, it is probable that the battery or charger is malfunctioning. Take it to your authorized Service Center.**

PRIOR TO OPERATION

1. Preparing and checking the work environment
Make sure that the work site meets all the conditions laid forth in the precautions.
2. Checking the battery
Make sure that the battery is installed firmly. If it is at all loose it could come off and cause an accident.
3. Selecting the socket matched to the bolt
Be sure to use a socket which is matched to the bolt to be tightened. Using an improper socket will not only result in insufficient tightening but also in damage to the socket or nut. A worn or deformed hex. or square-holed socket will not give an adequate tightness for fitting to the nut or anvil, consequently resulting in loss of tightening torque.
Pay attention to wear of socket hole, and replace before further wear has developed.

4. Installing a socket
Select the socket to be used.

CAUTION

Please use the designated attachments which are listed in the operations manual and HiKOKI's catalog. Accidents or injuries could result from not doing so.

- Pin, O-ring type <WR36DF>
- (1) Slide the O-ring out of the groove, then align the hole of the socket with the hole of the anvil and insert the anvil into the socket. (Fig. 9)

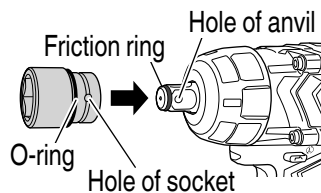

Fig. 9

- (2) Insert the pin into the socket. (Fig. 10)

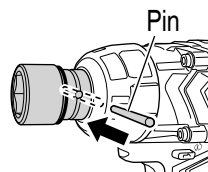

Fig. 10

- (3) While making sure that the pin doesn't fall, attach the O-ring to the groove on the socket. (Fig. 11, 12)

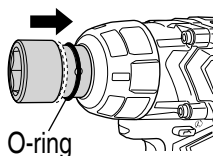

Fig. 11

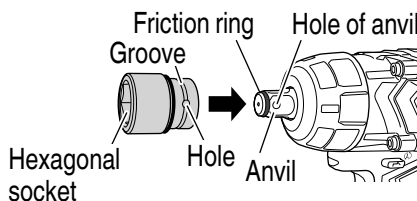

Fig. 12

CAUTION

- Make sure to firmly install the socket in the anvil. If the socket is not firmly installed it might come out and cause injuries.
- When sliding the O-ring out of the groove of the socket, be careful not to drop and lose the pin.

English

● <WR36DG> (Fig. 13)

- (1) Align the square portions of the socket and the anvil with each other.
- (2) Make sure to firmly install the socket by pushing it all the way into the anvil.
- (3) When removing the socket, pull it out of the anvil.

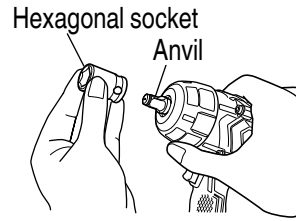

Fig. 13

CAUTION

Make sure to firmly install the socket in the anvil. If the socket is not firmly installed it might come out and cause injuries.

HOW TO USE

1. Check the rotational direction
The bit rotates clockwise (viewed from the rear side) by pushing the R-side of the pushing button.
The L-side of the pushing button is pushed to turn the bit counterclockwise. (See Fig. 14).
(The (L) and (R) marks are engraved on the body.)

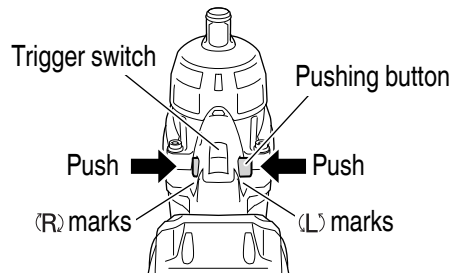

Fig. 14

CAUTION

The pushing button can not be switched while the impact wrench is turning. To switch the pushing button, stop the impact wrench, then set the pushing button.

2. Switch operation
 - When the trigger switch is depressed, the tool rotates. When the trigger switch is released, the tool stops.
 - The rotational speed can be controlled by varying the amount that the trigger switch is pulled. Speed is low when the trigger switch is pulled slightly and increases as the trigger switch is pulled more.
 - When releasing the trigger switch, the brake will be applied for immediate stopping.

NOTE

A buzzing noise is produced when the motor is about to rotate; this is only a noise, not a machine failure.

3. Tightening and loosening bolts
 A hex. socket matching the bolt or nut must first be selected. Then mount the socket on the anvil, and grip the nut to be tightened with the hex. socket. Holding the wrench in line with the bolt, press the power switch to impact the nut for several seconds. If the nut is only loosely fitted to the bolt, the bolt may turn with the nut, therefore mistaking proper tightening. In this case, stop impact on the nut and hold the bolt head with a wrench before restarting impact, or manually tighten the bolt and nut to prevent them slipping.
4. Using the hook
 The hook can be used to hang up the unit temporarily during operations. (Fig. 15)

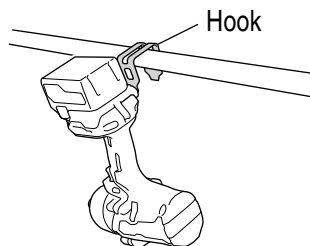

Fig. 15

CAUTION

The hook should never be used to hang the unit on your person.
When using the hook, check to make sure that the main unit will not slip and fall, or become unstable by the wind, etc.
Never hang the unit from your belt or trousers as this could cause accidents.

- (1) Removing the hook.
 Remove the screws fixing the hook with Philips screw driver. (Fig. 16)

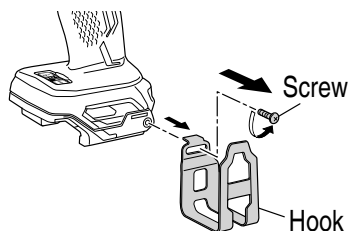

Fig. 16

- (2) Replacing the hook and tightening the screws.
 Install securely the hook in the groove of power tool and tighten the screws to fix the hook firmly. (Fig. 17)

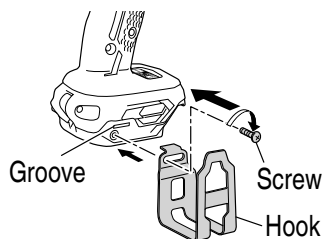

Fig. 17

English

5. Remaining battery indicator
You can check the battery's remaining capacity by pressing the remaining battery indicator switch to light the indicator lamp. (**Fig. 18, Table 4**)

The indicator will shut off approximately 3 seconds after the remaining battery indicator switch is pressed.

It is best to use the remaining battery indicator as a guide since there are slight differences such as ambient temperature and the condition of the battery.

Also, the remaining battery indicator may vary from those equipped to a tool or charger.

Remaining battery indicator lamp Remaining battery indicator switch

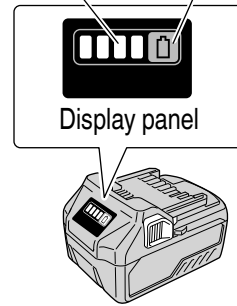

Fig. 18

Table 4

State of lamp	Battery Remaining Power
	Lights ; The battery remaining power is over 75%.
	Lights ; The battery remaining power is 50%–75%.
	Lights ; The battery remaining power is 25%–50%.
	Lights ; The battery remaining power is less than 25%.
	Blinks ; The battery remaining power is nearly empty. Recharge the battery soonest possible.
	Blinks ; Output suspended due to high temperature. Remove the battery from the tool and allow it to fully cool down.
	Blinks ; Output suspended due to failure or malfunction. The problem may be the battery so please contact your dealer.

As the remaining battery indicator shows somewhat differently depending on ambient temperature and battery characteristics, read it as a reference.

NOTE

Do not give a strong shock to the switch panel or break it. It may lead to a trouble.

6. How to use the LED light
 While the trigger switch is pulled, the LED light will automatically light up the tip portion of the tool. (Fig. 19)
 The LED light will automatically turn off 10 seconds after the trigger switch is released.

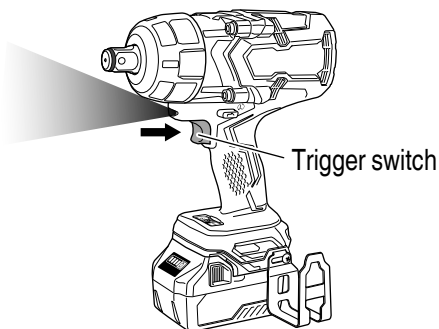

Fig. 19

CAUTION

- Do not expose directly your eye to the light by looking into the light. If your eye is continuously exposed to the light, your eye will be hurt.
 - Wipe off any dirt or grime attached to the lens of the LED light with a soft cloth, being careful not to scratch the lens. Scratches on the lens of the LED light can result in decreased brightness.
7. Tightening mode selector function

CAUTION

- Do not subject the switch panel to shock or damage.
- Select tightening mode while the trigger switch is released. Failure to do so could result in malfunction.

Tightening torque can be adjusted according to the type of work by combined use of the High / Low mode selector switch and the Auto stop mode selector switch. (Fig. 20)

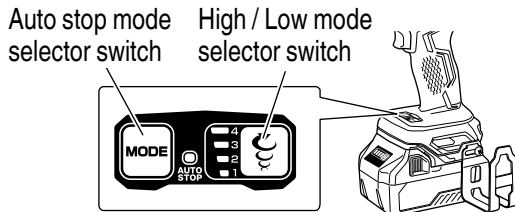

Fig. 20

English

- (1) High / Low mode selector switch (**Fig. 21**)
 The tightening mode switches between 4 different rotation speeds each time the High / Low mode selector switch is pressed.

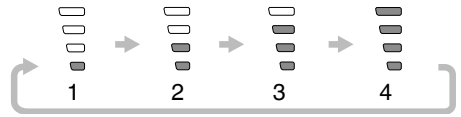

Fig. 21

Table 5

High / Low mode setting

High / Low mode	1	2	3	4
Indicator lamps				
Maximum unloaded speed (/min)	600	900	1200	1500
Auto stop / Auto slow mode	OFF			
Uses	For work that requires fine adjustments.		For work that requires the power to be suppressed.	For work that requires power and speed.

- (2) Auto stop mode selector switch (**Fig. 22**)
 Pressing the Auto stop mode selector switch toggles the mode.

Auto stop mode selector switch

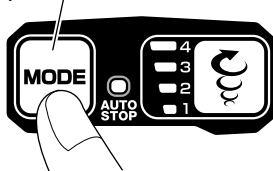

Forward: Auto stop mode
 Reverse: Auto slow mode

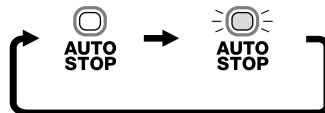

Fig. 22

- (3) Auto stop mode (**Fig. 23, Table 6**)
 Stops automatically after a preset time has elapsed.
 Push the pushing button to the forward (“R”) position, then press the Auto stop mode selector switch to select the setting.

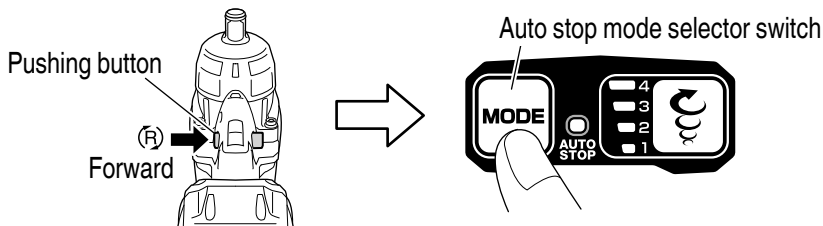

Fig. 23

Table 6

Auto stop mode setting

	Auto stop mode			
	1	2	3	4
Indicator lamps				
Maximum unloaded speed (/min)	600	900	1200	1500
Auto stop time	Stops within 1.2 seconds after impact begins.			
Uses	Steel frame temporary tightening, etc.	Truck wheel nut or piping temporary tightening, etc.	Heavy machinery or bridge girder temporary tightening, etc.	

English

(4) Auto slow mode (Fig. 24, Table 7)

Stops for a preset time and/or changes the speed automatically to a preset speed. Push the pushing button to the reverse (“L”) position, then press the Auto stop mode selector switch to select the setting.

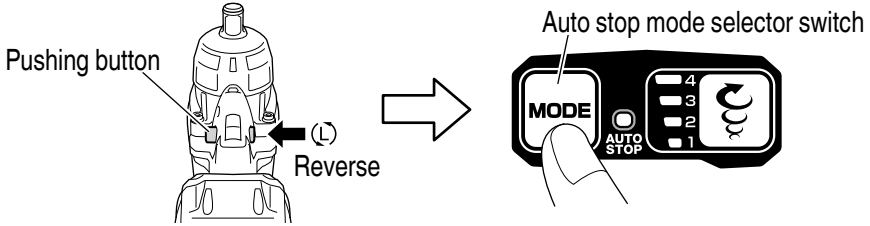

Fig. 24

Table 7

Auto slow mode setting

		Auto slow mode			
		1	2	3	4
Indicator lamps					
Auto slow operation	Trigger displacement: Maximum	Pauses after bolt loosening is detected. Restarts after stopping for 0.5 seconds, then rotates at 60–350 (/min) depending on how far the trigger is pulled. * Rotation does not stop after restarting.			
	Trigger displacement: Halfway	Rotation speed is reduced as follows depending on how far the trigger is pulled after starting. * Rotation does not stop.			
Uses		60–330 (/min)	60–500 (/min)	60–660 (/min)	60–830 (/min)
		For work of loosening bolt or nuts			

This function helps prevent nuts from dropping when loosening them.

NOTE

- Depending on factors such as the bolt or nut size, socket used, and extent of tightening, there is a risk of nuts accidentally dropping if the nut becomes detached from the screw thread while the power tool is operating.
- The appropriate mode differs depending on the bolt and the material being screwed. Tighten in a few test bolts and adjust the mode setting accordingly.
- The tightening mode selector switch can only be set after the battery has been installed in the wrench and the trigger switch has been pulled once.

OPERATIONAL CAUTIONS

1. Resting the unit after continuous work
 The power tool is equipped with a temperature protection circuit to protect the motor. Continuous work may cause the temperature of the unit to rise, activating the temperature protection circuit and automatically stopping operation. If this happens, allow the power tool to cool before resuming use.
 The motor may stop in the event the tool is overloaded. In this should occur, release the tool's switch and eliminate the cause of the overload.
 After use for continuous work, rest the unit for 15 minutes or so when replacing the battery. The temperature of the motor, switch, etc., will rise if the work is started again immediately after battery replacement, eventually resulting in burnout.

NOTE

Do not touch the hammer case as it gets very hot during continuous work.

2. Cautions on use of the speed control switch
 This switch has a built-in, electronic circuit which steplessly varies the rotation speed. Consequently, when the trigger switch is pulled only slightly (low speed rotation) and the motor is stopped while continuously driving in screws, the components of the electronic circuit parts may overheat and be damaged.
3. Work at a tightening torque suitable for the bolt under impact
 The optimum tightening torque for nuts or bolts differs with material and size of the nuts or bolts. An excessively large tightening torque for a small bolt may stretch or break the bolt. The tightening torque increases in proportion to the operation time. Use the correct operating time for the bolt.
4. Holding the tool
 Hold the tool firmly with both hands. In this case hold the tool in line with bolt. It is not necessary to push the tool very hard. Hold the tool with a force just sufficient to counteract the impact force.
5. Confirm the tightening torque
 The following factors contribute to a reduction of the tightening torque. So confirm the actual tightening torque needed by screwing up some bolts before the job with a hand torque wrench. Factors affecting the tightening torque are as follows.
 - (1) Voltage
 When the discharge margin is reached, voltage decreases and tightening torque is lowered.
 - (2) Operating time
 The tightening torque increases when the operating time increases. But the tightening torque does not increase above a certain value even if the tool is driven for a long time.
 - (3) Diameter of bolt
 The tightening torque differs with the diameter of the bolt. Generally a larger diameter bolt requires larger tightening torque.

English

- (4) **Tightening conditions**
The tightening torque differs according to the torque ratio; class, and length of bolts even when bolts with the same size threads are used. The tightening torque also differs according to the condition of the surface of workpiece through which the bolts are to be tightened. When the bolt and nut turn together, torque is greatly reduced.
- (5) **Using optional parts**
The tightening torque is reduced a little when an extension bar, universal joint or a long socket is used.
- (6) **Clearance of the socket**
A worn or deformed hex. or a square-holed socket will not give an adequate tightness to the fitting between the nut or anvil, consequently resulting in loss of tightening torque. Using an improper socket which does not match to the bolt will result in an insufficient tightening torque.
- (7) **Tightening torque varies, depending on the battery's charge level.**

HOW TO RECHARGE USB DEVICE

WARNING

- **Prior to use, check the connecting USB cable for any defect or damage. Using a defective or damaged USB cable can cause smoke emission or ignition.**
- **When the product is not being used, cover the USB port with the rubber cover. Buildup of dust etc. in the USB port can cause smoke emission or ignition.**

NOTE

- **There may be an occasional pause during USB recharging.**
 - **When a USB device is not being charged, remove the USB device from the charger. Failure to do so may not only reduce the battery life of a USB device, but may also result in unexpected accidents.**
 - **It may not be possible to charge some USB devices, depending on the type of device.**
- (1) **Select a charging method**
Depending on the charge method selected, either the battery is inserted into the charger or the power cord is plugged into an outlet.
 - **Charging a USB device from a electrical outlet (Fig. 25-a).**
 - **Charging a USB device and battery from a electrical outlet. (Fig. 25-b)**

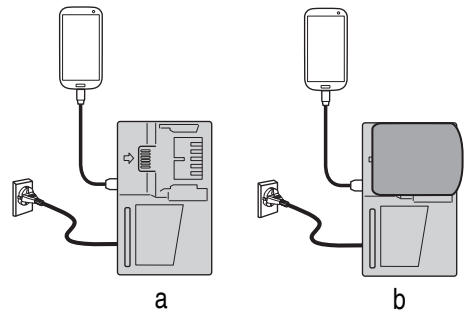

Fig. 25

- (2) Connect the USB cable. **(Fig. 26)**
 Pull back the rubber cover and firmly plug in a commercially available USB cable (appropriate to the device being charged) into the USB port.

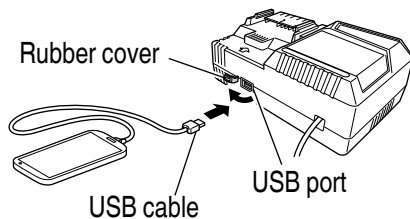

Fig. 26

- (3) When charging is completed
- To verify charge status, check the USB device.
 - Unplug the power cord from the electrical outlet. **(Fig. 27)**
 - Place the rubber cover over the USB port.

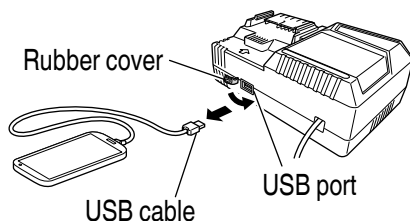

Fig. 27

MAINTENANCE AND INSPECTION

WARNING

Be sure the switch is in the OFF position, and pull out the battery before doing any inspection or maintenance.

1. Inspecting the socket
 A worn or deformed hex. or a square-holed socket will not give an adequate tightness to the fitting between the nut or anvil, consequently resulting in loss of tightening torque. Pay attention to wear of a socket holes periodically, and replace with a new one if needed.
2. Inspecting the mounting screws
 Regularly inspect all mounting screws and ensure that they are properly tightened. Should any of the screws be loose, retighten them immediately. Failure to do so may result in serious hazard.
3. Maintenance of the motor
 The motor unit winding is the very "heart" of the power tool.
 Exercise due care to ensure the winding does not become damaged and/or wet with oil or water.
4. Inspection of terminals (tool and battery)
 Check to make sure that swarf and dust have not collected on the terminals.
 On occasion check prior, during and after operation.

CAUTION

**Remove any swarf or dust which may have collected on the terminals.
 Failure to do so may result in malfunction.**

English

5. Cleaning of the outside

When the impact wrench is stained, wipe with a soft dry cloth or a cloth moistened with soapy water. Do not use chloric solvents, gasoline or paint thinner, as they melt plastics.

6. Storage

Store the power tool and battery in a place in which the temperature is less than 40°C, and out of reach of children.

NOTE

Storing Lithium-ion Batteries

Make sure the batteries have been fully charged before storing them.

Prolonged storage (3 months or more) of batteries with a low charge may result in performance deterioration, significantly reducing battery usage time or rendering the batteries incapable of holding a charge.

However, significantly reduced battery usage time may be recovered by repeatedly charging and using the batteries two to five times.

If the battery usage time is extremely short despite repeated charging and use, consider the batteries dead and purchase new batteries.

CAUTION

In the operation and maintenance of power tools, the safety regulations and standards prescribed in each country must be observed.

Important notice on the batteries for the HiKOKI cordless power tools

Please always use one of our designated genuine batteries. We cannot guarantee the safety and performance of our cordless power tool when used with batteries other than these designated by us, or when the battery is disassembled and modified (such as disassembly and replacement of cells or other internal parts).

TROUBLESHOOTING

Use the inspections in the table below if the tool does not operate normally. If this does not remedy the problem, consult your dealer or the HIKOKI Authorized Service Center.

Symptom	Possible cause	Remedy
Tool doesn't run	No remaining battery power	Charge the battery.
Tool suddenly stopped	Tool was overburdened	Get rid of the problem causing the overburden.
	The battery is overheated.	Let the battery cool down.
	The trigger switch was held down for 5 minutes or more.	This is not a malfunction. The motor was automatically stopped to prevent failure of the tool.
Tool sockets -can't be attached -fall off -can't be removed	The shape of the attachment portion doesn't match	Make sure to use sockets with the appropriate square drive size. WR36DF: 19 mm WR36DG: 12.7 mm
Switch can't be pulled	Pushing button is positioned halfway	Press the button firmly into position for the desired direction of rotation.
An abnormal high-pitched noise occurs when the trigger switch is pulled.	The trigger switch is being pulled only slightly.	This is not a malfunction. It does not occur if the trigger switch is pulled more fully.
Battery cannot be installed	Attempting to install a battery other than that specified for the tool.	Please install a multi volt type battery.

SELECTING ACCESSORIES

Select accessories that are suited to a specific task.
For details contact HiKOKI Authorized Service Center.

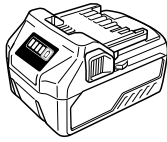

BSL36A18
Battery

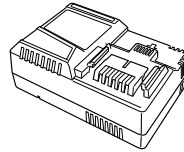

UC18YSL3
(14.4 V–18 V)
Charger

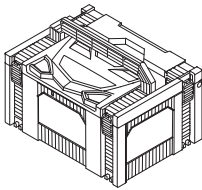

Part Number: 337108
Case (Stackable)

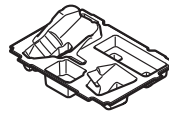

Part Number: 375578

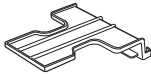

Part Number: 329897
Battery cover

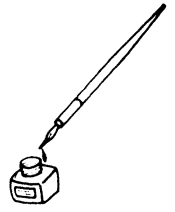

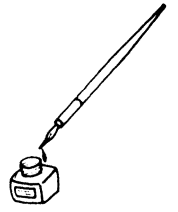

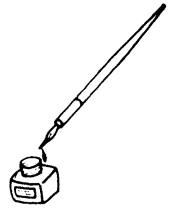

服务中心
高壹工机商业(上海)有限公司
上海市闵行区浦江工业园区三鲁路3585号7幢3楼

制造商
广东高壹工机有限公司
广东省广州市番禺区化龙镇工业路富裕围工业村

Koki Holdings Co., Ltd.

208
编号: C99746221 G
发行日期: 2022年 8月
中国印刷