

HiKOKI

中文
English

充电式轨道砂光机
Cordless Random Orbit Sander

SV 1813DA



保留备用
Keep for future reference



使用说明书
Handling instructions

目次

电动工具通用安全警告.....	2	用途.....	10
充电式轨道砂光机安全警告.....	5	电池的拆卸 / 安装法.....	11
其他安全警告.....	5	充电.....	11
锂离子电池使用注意事项.....	6	作业之前.....	14
锂离子电池运输.....	8	操作.....	16
符号.....	8	如何安装所选附件.....	18
零件名称.....	9	安装集尘器装置.....	18
规格.....	9	维护和检查.....	19
标准附件.....	10	选择附件.....	21

电动工具通用安全警告

⚠ 警告！

阅读电动工具附带的所有安全警告、说明、插图和规格说明。
不遵照以下说明会导致电击、着火和 / 或严重伤害。

保存所有警告和说明书以备查阅。

在所有下列的警告中术语“电动工具”指市电驱动（有线）电动工具或电池驱动（无线）电动工具。

1) 工作场地的安全

- a) 保持工作场地清洁和明亮。
混乱和黑暗的场地会引发事故。
- b) 不要在易爆环境，如有易燃液体、气体或粉尘的环境下操作电动工具。
电动工具产生的火花会点燃粉尘或气体。
- c) 让儿童和旁观者离开后操作电动工具。
注意力不集中会使操作者失去对工具的控制。

2) 电气安全

- a) 电动工具插头必须与插座相配。绝不能以任何方式改装插头。
需接地的电动工具不能使用任何转换插头。
未经改装的插头和相配的插座将减少电击危险。
- b) 避免人体接触接地表面，如管道、散热片和冰箱。
如果你身体接地会增加电击危险。
- c) 不得将电动工具暴露在雨中或潮湿环境中。
水进入电动工具将增加电击危险。
- d) 不得滥用电线。绝不能用电线搬运、拉动电动工具或拔出其插头。使电线远离热源、油、锐边或运动部件。
受损或缠绕的软线会增加电击危险。

- e) 当在户外使用电动工具时，使用适合户外使用的外接软线。
适合户外使用的软线将减少电击危险。
- f) 如果在潮湿环境下操作电动工具是不可避免的，应使用剩余电流动作保护器（RCD）。
使用RCD可减小电击危险。

3) 人身安全

- a) 保持警觉，当操作电动工具时关注所从事的操作并保持清醒。
当你感到疲倦，或在有药物、酒精或治疗反应时，不要操作电动工具。
在操作电动工具时瞬间的疏忽会导致严重人身伤害。
- b) 使用个人防护装置。始终佩戴护目镜。
安全装置，诸如适当条件下使用防尘面具、防滑安全鞋、安全帽、听力防护等装置能减少人身伤害。
- c) 防止意外起动。确保开关在连接电源和 / 或电池盒、拿起或搬运工具时处于关断位置。
手指放在已接通电源的开关上或开关处于接通时插入插头可能会导致危险。
- d) 在电动工具接通之前，拿掉所有调节钥匙或扳手。
遗留在电动工具旋转零件上的扳手或钥匙会导致人身伤害。
- e) 手不要伸展得太长。时刻注意立足点和身体平衡。
这样在意外情况下能很好地控制电动工具。
- f) 着装适当。不要穿宽松衣服或佩戴饰品。让衣服、手套和头发远离运动部件。
宽松衣服、佩饰或长发可能会卷入运动部件中。
- g) 如果提供了与排屑、集尘设备连接用的装置，要确保它们连接完好且使用得当。
使用这些装置可减少尘屑引起的危险。
- h) 请勿因频繁使用工具的熟悉感而掉以轻心，忽视工具的安全性原则。
粗心的行为可能会导致瞬间发生严重伤害。

4) 电动工具使用和注意事项

- a) 不要滥用电动工具，根据用途使用适当的电动工具。
选用适当设计的电动工具会使你工作更有效、更安全。
- b) 如果开关不能接通或关断工具电源，则不能使用该电动工具。
不能用开关来控制的电动工具是危险的且必须进行修理。
- c) 在进行任何调整、更换附件或存放电动工具之前，必须从电源上拔掉插头和 / 或取下电池盒（如果可拆卸）。
这种防护性措施将减少工具意外起动的危险。
- d) 将闲置不用的电动工具贮存在儿童所及范围之外，并且不要让不熟悉电动工具或对这些说明不了解的人操作电动工具。
电动工具在未经培训的用户手中是危险的。

中文

- e) 维护电动工具和附件。检查运动件是否调整到位或卡住，检查零件破损情况和影响电动工具运行的其他状况。如有损坏，电动工具应在使用前修理好。

许多事故由维护不良的电动工具引发。

- f) 保持切削刀具锋利和清洁。

保养良好的有锋利切削刃的刀具不易卡住而且容易控制。

- g) 按照使用说明书，考虑作业条件和进行的作业来使用电动工具、附件和工具的刀头等。

将电动工具用于那些与其用途不符的操作可能会导致危险。

- h) 保持手柄和抓握表面干燥、清洁，远离油和油脂。

如果手柄和抓握表面湿滑，可能导致在发生意外情况时，无法安全操作和控制工具。

5) 电池式工具使用和注意事项

- a) 只用制造商规定的充电器充电。

将适用于某种电池盒的充电器用到其他电池盒时会发生着火危险。

- b) 只使用配有特制电池盒的电动工具。

使用其他电池盒会发生损坏和着火危险。

- c) 当电池盒不用时，将它远离其他金属物体，例如回形针、硬币、钥匙、钉子、螺钉或其他小金属物体，以防一端与另一端连接。

电池端部短路会引起燃烧或火灾。

- d) 在滥用条件下，液体会从电池中溅出；避免接触。如果无意间碰到了，用水冲洗。如果液体碰到了眼睛，还要寻求医疗帮助。

从电池中溅出的液体会发生腐蚀或燃烧。

- e) 请勿使用损坏或改装的电池盒或工具。

损坏或改装的电池可能会引发突发状况，导致火灾、爆炸或受伤。

- f) 请勿将电池盒或工具暴露在有火源或高温环境中。

如果暴露在有火源或 130 度以上高温的环境中，可能引起爆炸。

- g) 请完全按照充电说明进行操作，不要在说明中规定的温度范围外的环境中对电池盒或工具充电。

充电不当或在规定温度范围外的环境中充电可能会导致电池损坏，增加发生火灾的风险。

6) 维修

- a) 将你的电动工具送交专业维修人员，使用同样的备件进行修理。

这样将确保所维修的电动工具的安全性。

- b) 请勿维修已损坏的电池盒。

需由制造商或经授权的服务供应商进行维修。

注意！

不可让儿童和体弱人士靠近工作场所。

应将不使用的工具存放在儿童和体弱人士接触不到的地方。

充电式轨道砂光机安全警告

1. 在操作过程中，切削工件可能会触碰到隐藏的线缆，因此请握住工具的绝缘夹持面。与“带电”导线接触时，工具暴露的金属部件将处于“带电”状态，并电击操作者。

其他安全警告

1. 请使用夹具或其他实用方法将工件固定并支撑在稳定的平台上。用手或身体抓持工件将使工件不稳，并可能导致失控。
2. 安装和拆卸粉尘袋
在打磨操作之前要先确定打磨的表面材料。
如果要进行打磨操作的表面会产生有害或有毒的粉尘，例如由铅着色的表面，就要确保粉尘袋或适当的粉尘抽取系统要和粉尘排放口紧密地连接在一起。
如有，另请佩戴上防尘面具。
不要吸入或接触在打磨过程中产生的有害或有毒的粉尘，这类粉尘会危及到操作者自身及旁观者的身体健康。
3. 打磨时切勿喷水或磨削液。否则会导致触电。
4. 切勿在砂光机接触打磨面时打开电源开关。这可保护材料免受损坏。关闭电源时同样如此。
5. 打磨时切勿对砂光机用力过猛。否则会导致电动机过载，砂纸使用寿命降低，以及打磨或抛光效率低下。
6. 请勿触碰移动的部件。
请勿将手、手指或身体的其他部位靠近工具的移动部件。
7. 请勿使工具在无人值守的状态下运转。关闭电源。请勿在工具完全停止前离开。
8. 操作工具时，请勿佩戴工作手套，因为手套的布料可能会卷入工具中。
9. 作业时请勿离开电动工具。该电动工具仅支持手持作业。
10. 使用前请确保垫板上无破裂、划痕或其他异常现象。
11. 请务必将附件牢固安装到工具上。
防止自己或他人受伤。附件必须安全牢靠地安装到工具上。
12. 请使用 HiKOKI 指定的砂纸及附件。
13. 打磨金属时会产生火花。请勿使用粉尘袋，并确保他人及易燃物远离工作区域。
14. 如果发现本机正在产生异常高温、工作不正常或出现异常噪音，请立即停止使用，并关闭电源。请让本机的经销商或 HiKOKI 授权服务中心检查和修理。
操作出现异常而依然继续使用时，可能会造成人身伤害。
15. 如果本机意外跌落或撞击其他物体，请彻底检查其是否发生破裂、破损或变形等。
如果本机破裂、破损或变形，可能会造成人身伤害。

中文

16. 在较高的位置作业时，请确保下方没有人，并注意下方的情况。
17. 务请在 0°C — 40°C 的温度下进行充电。温度低于 0°C 将会导致充电过度，极其危险。电池不能在高于 40°C 的温度下充电。
最适合于充电的温度是 20 — 25°C 。
18. 不要连续使用充电器。
一次充电完毕后，在15分钟内不要再次使用该充电器对电池充电。
19. 请勿让杂质进入充电式电池连结口内。
20. 切勿拆卸充电式电池与充电器。
21. 切勿使充电式电池短路。电池短路会引起强电流和过热。从而烧坏电池。
22. 请勿将电池丢入火中。电池受热将会爆炸。
23. 充电后电池寿命太短不够使用时，请尽快将电池送往经销店。请勿将用过的电池乱丢。
24. 请勿将异物插入充电器的通风口。若将金属异物或易燃物插入通风口，将会引起触电事故或使充电器受损。
25. 长时间连续使用本机，可能导致机体过热，对马达及开关造成损害。因此，机壳变热时，请让工具休息一段时间。
26. 请确保蓄电池安装牢固。电池松动后，可能脱落并引起事故。
27. 请勿使用工具或电池端子（电池安装部位）明显变形的产品。
否则，安装电池后可能会短路，造成冒烟或起火。
28. 请清除工具端子（电池安装部位）上的削屑和灰尘。
 - 使用前，请确保电池上没有堆积削屑和灰尘。
 - 在使用过程中，请尽量避免工具上的削屑或灰尘掉落到电池上。
 - 暂停不使用工具时或使用后，应将工具存放在不会掉落削屑或灰尘的地方。
否则可能短路，造成冒烟或起火。
29. 请在 -5 — 40°C 环境下使用本工具及电池。

锂离子电池使用注意事项

为延长使用期限，锂离子电池备配停止输出的保护功能。

若是在使用本产品时发生下列 1 至 3 的情况，即使按下开关，马达也可能停止。这并非故障，而是启动保护功能的结果。

1. 在残留的电池电力即将耗尽时，马达会停止。
在这种情况下，请立即予以充电。
2. 若工具超过负荷，马达亦可能停止。在这种情况下，请松开工具的开关，试着消除超过负荷的原因。之后您就可以再度使用。
3. 若电池在过载工作情况下过热，电池电力可能会中止。
在这种情况下，请停止使用电池，让电池冷却。之后您就可以再度使用。

此外，请留心下列的警告及注意事项。

警告！

为防止发生电池漏电、发热、冒烟、爆炸及提前点燃，请确保留意下列事项。

1. 确保电池上没有堆积削屑及灰尘。
 - 在工作时确定削屑及灰尘没有掉落在电池上。
 - 确定所有工作时掉落在电动工具上的削屑和灰尘没有堆积在电池上。
 - 请勿将未使用的电池存放在曝露于削屑和灰尘的位置。
 - 在存放电池之前，请清除任何可能附着在上面的削屑和灰尘，并请切勿将它与金属零件（螺丝、钉子等）存放在一起。
2. 请勿以钉子等利器刺穿电池、以铁锤敲打、踩踏、丢掷电池，或将其剧烈撞击。
3. 切勿使用明显损坏或变形的电池。
4. 请依规定方式使用电池，切勿移作他用。
5. 如果已过了再充电时间，电池仍无法完成充电，请立即停止继续再充电。
6. 请勿将电池放置于高温或高压处，例如微波炉、烘干机或高压容器内。
7. 在发觉有渗漏或异味时，请勿接近远离火源。
8. 请勿在会产生强烈静电的地方使用。
9. 如有电池渗漏、异味、发热、褪色或变形，或在使用、充电或存放时出现任何异常，请立即将它从装备或电池充电器拆下，并停止使用。
10. 请勿浸泡电池或让任何液体流入电池内部。导电液体进入（如水），可能造成电池损坏，甚至可导致火灾或爆炸。将电池存放在阴凉、干燥的地方，远离易燃物品。必须避免将电池置于腐蚀性气体环境中。

注意！

1. 若电池渗漏出的液体进入您的眼睛，请勿搓揉眼睛，并以自来水等干净清水充分冲洗，立刻送医。
若不加以处理，液体可能会导致眼睛不适。
2. 若液体渗漏至您的皮肤或衣物，请立即以自来水等清水冲洗。
上述情况可能会使皮肤受到刺激。
3. 若初次使用电池时发现生锈、异味、过热、褪色、变形及 / 或其它异常情况时，请勿使用并将该电池退还给供货商或厂商。

警告！

如果导电异物接触到锂离子电池的端子，电池可能短路，并导致火灾。

存放锂离子电池时，请务必遵循下列注意事项。

- 切勿在存放盒中放置导电的残片，钉子，以及导线，如铁线和铜线。
- 为防止发生短路，应将电池装入工具中或者在存放时牢固地插入电池盖，直至看不到通风口。（参照图 1）



图 1

锂离子电池运输

当运输一个锂离子电池，请注意以下预防措施。

警告！

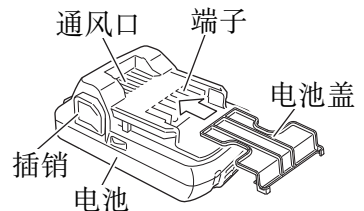
告知运输公司，包装内包含一个锂离子电池，告知该公司其功率输出并且要按照运输公司的指引安排运输。

- 功率输出超过 100Wh 的锂离子电池被视作危险物品运输分类并且需要特别申请程序。
- 对于境外运输，您必须遵守国际法以及输入国的规章和条例。



图 2

符号

警告！

如下所示的符号用于本机。使用前请务必理解其含意。

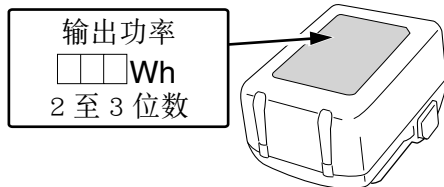
	为降低伤害风险，用户必须阅读使用说明书	n_0	无负荷速度
	直流电	/min	每分钟的振动次数
V	额定电压		警告

零件名称

1. 电动工具



图 3

2. 电池 (选购件)

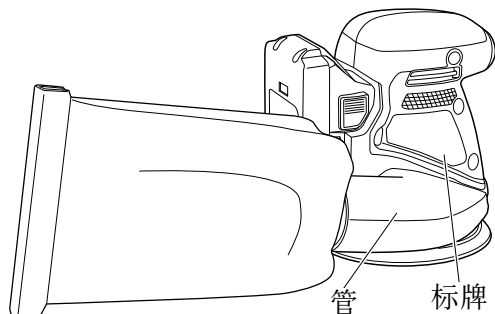
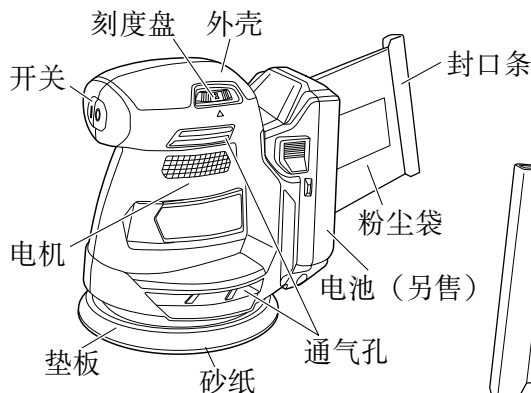
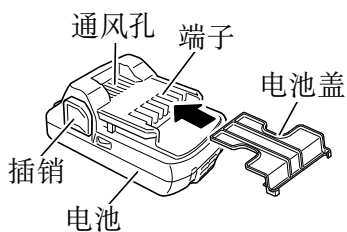

<BSL1830C>

图 4

3. 电池充电器 (选购件)

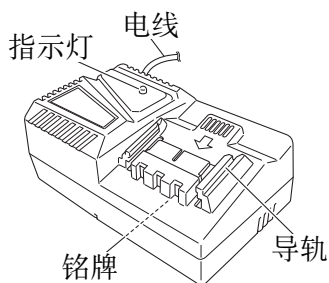

<UC18YFSL>

图 5

规格

型式	SV1813DA
电压	18V
空载转速	7000—11000/min
砂纸垫板尺寸 (外径)	125mm
砂纸尺寸 (外径)	125mm
电池	BSL1830C: 锂离子 18V (3.0Ah, 5 节)
重量	1.6 kg (安装 BSL1830C)

中文

电子控制

制动功能

当开关被关闭时，会激活制动器，将停止电机的旋转。





充电器（另售）

型式	UC18YFSL
充电电压	14.4V - 18V
重量	0.5kg

标准附件

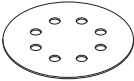
除了主机（1台）外，产品包中还包括表中所列的附件。

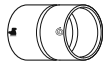
表 1

		SV1813DA
		(NN)
砂纸		1
真空适配器 (A)		1
真空适配器 (B)		1
粉尘袋		1

用途

- 木工件和金属表面的粗略打磨或抛光。
- 木工件和金属表面在油漆前的初步打磨。
- 除漆。
- 除锈。

电池的拆卸 / 安装法

1. 电池的拆卸法

请先紧抓住把手，然后再推压电池插销以拆下电池（参照图 6）。

注意！

切勿使电池短路。

2. 电池的安装法

插入电池时请注意极性（参照图 6）



图 6

充电

使用电动工具之前，按下述方法将电池进行充电。

1. 将充电器的电源线连接到插座。

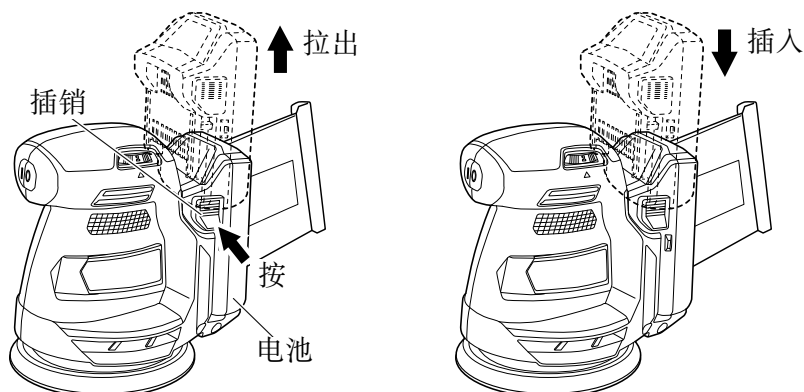
将充电器插头连接到插座时，指示灯闪烁红色（间隔为 1 秒）。

2. 将电池插入充电器。

如图 7 所示，将电池紧紧地插入充电器。

3. 充电

将电池插入充电器后，将开始充电，指示灯会持续点亮呈红色。

电池完全充电后，指示灯将闪烁呈红色（以 1 秒的间隔）（参照如第 12 页的表 2）。







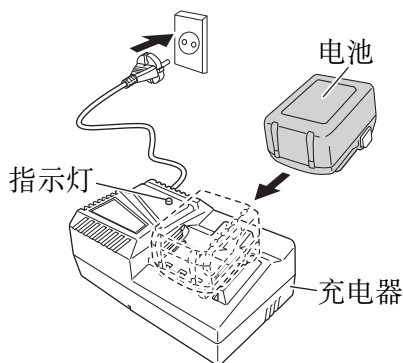

图 7

中文

● 指示灯显示

根据充电器或充电式电池的情况，指示灯的显示如表 2 所示。

表 2

指示灯的显示			
指示灯 (红色)	充电前	点亮 0.5 秒钟，不点亮 0.5 秒钟 闪烁 (熄灭 0.5 秒钟) 	插入电源
	充电时	点亮 连续点亮 	/
	充电完成	点亮 0.5 秒钟，不点亮 0.5 秒钟 闪烁 (熄灭 0.5 秒钟) 	
	过热而等待	点亮 1 秒钟，不点亮 0.5 秒钟 闪烁 (熄灭 0.5 秒钟) 	电池过热。无法充 (电池冷却后开始进行充电)。
	无法充电	点亮 0.1 秒钟，不点亮 0.1 秒钟 闪动 (熄灭 0.1 秒钟) 	电池或充电器有问题。

● 电池温度和充电时间相关资料。

温度和充电时间如表 3 所示

表 3

电池		充电器	UC18YFSL
充电电压	V		14.4 - 18
重量	kg		0.5
电池可充电温度			0°C - 50°C
电池容量的大致充电时间 (20°C 下)			
1.5 Ah	分钟		22
2.0 Ah	分钟		30
2.5 Ah	分钟		35
3.0 Ah	分钟		45
4.0 Ah	分钟		60
5.0 Ah	分钟		75
6.0 Ah	分钟		90
8.0 Ah	分钟		120
电池数			4 - 10

注：

充电时间可能根据环境温度和电压而有变化。

注意！

连续使用时，电池充电器温度将提升，因此会导致出现故障。完成充电后，下次充电前，请让电池充电器休息 15 分钟。

4. 从电源插座拔下充电器的电源线。

5. 握紧充电器并取出电池。

注：

充电后，先将电池从充电器中取出，然后妥善保存。

关于新电池的放电。

新电池内部的化学物质未被激活或电池长时间不使用时，初次或第二次使用时需要将其放电至较低电量。这只是暂时现象，将电池充电2-3次即可恢复为充电所需的正常时间。

较长时间保持电池性能的方法

(1) 在电池电力完全耗尽之前进行充电。

感到电动工具的能力变弱时，请停止使用并给电池充电。若您继续使用电动工具并耗尽电力，电池可能会损坏或其使用寿命缩短。

(2) 避免在高温环境中充电。

使用后可充电电池的温度将迅速升高。若使用后立即对这种电池进行充电，其内部化学物质会劣化，电池使用寿命将缩短。请稍等片刻，待电池冷却后再进行充电。

注意！

○ 如果电池长时间放置在阳光直接照射的地方或者刚刚使用完毕时，电池会变热。如果此时对电池充电，充电器上的指示灯会点亮 1 秒钟，不点亮 0.5 秒钟（熄灭 0.5 秒钟）。

在此情况下，先让电池冷却下来，然后再充电。

○ 指示灯闪动时（以 0.2 秒钟的间隔），请检查并取出充电器电池接口处的任何异物。若无异物，则可能电池或充电器发生故障。请带去经授权的维修中心检查。

○ 如果指示灯未以红色闪烁（每秒一次），但充电池电源线已连接至电源，表明充电器的保护电路可能已激活。

拔下电源线或插座，然后等待 30 秒左右再次连接。如果指示灯仍未以红色闪烁（每秒一次），请将充电器送还至 HiKOKI 授权服务中心。

作业之前

警告！

为避免发生严重事故，请确保开关处于关断位置，并取出电池。

1. 检查工作区域环境。
检查工作区域，确保没有杂物且不杂乱。
请勿使无关人员靠近。确保照明和通风充足。
2. 电源开关
确认电源开关是否切断。
3. 安装砂纸

注意！

- 请勿使用产品铭牌规定的砂纸尺寸以外的砂纸。
- 请勿使用附着性差的附件。

由于砂纸的安装属于钩环型安装，因此只需将砂纸按压在垫板上即可。

- (1) 轻轻捏住砂纸边缘的两处，以使底部的两个孔可见。(图 8-a)



图 8-a

- (2) 将砂纸的两个孔与垫板的两个孔对齐，并将整张砂纸表面贴到垫板上，以对齐剩余的孔。(图 8-b)

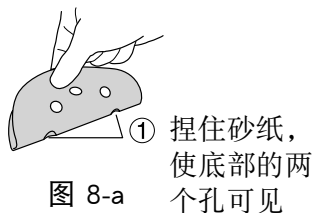

图 8-b

4. 安装和拆卸粉尘袋（图 9）

(1) 安装粉尘袋

将粉尘袋插入电动工具主体的管中。

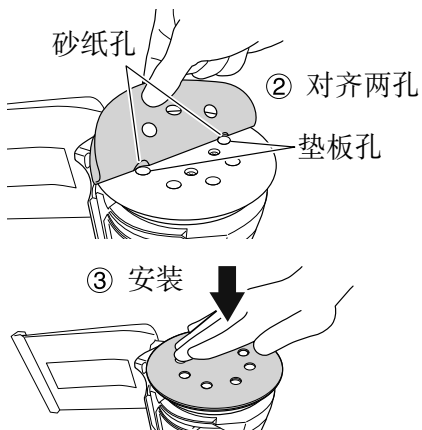
(2) 拆卸粉尘袋

握住管子，拉出粉尘袋。

警告！

在打磨操作之前要先确定打磨的表面材料。

如果要进行打磨操作的表面会产生有害或有毒的尘土，例如由铅着色的表面，就要确保装尘土的袋子或适当的尘土抽取系统要和尘土排放口紧密地连接在一起。

如果有必要，另外还要带上防尘面具。

不要吸入或接触在打磨过程中产生的有害或有毒的尘土，这类尘土会危及到操作者自身及旁观者的身体健康。



图 9

注意！

如果粉尘袋内积尘过多，会导致集尘性能降低。请尽快倒掉。

5. 调整速度

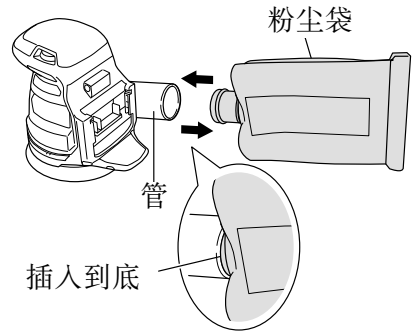
砂光机配备有可实现速度控制的电气控制电路。要调整速度，如图 10 所示转动拨盘。拨盘设为“1”时，砂光机以最小速度（7000/min）运行；拨盘设为“6”时，砂光机以最大速度（11000/min）运行。请根据要切削的材料和工作效率调整速度。



图 10

中文

表 4 通过调整拨盘，使速度符合材料和工件类型的要求。

材料	颗粒度		拨盘刻度
	粗略打磨	精细打磨	
油漆件： 打磨 修复 (划伤、锈点) 去除漆层	180	400	3-6
	120	240	2-4
	40	80	2-4
木工件： 软木 硬木 胶合板	60-80	240	3-6
	60	180	3-5
	240	320	2-4
金属： 铝 钢 不锈钢	80	240	2-4
	60	240	3-6
	120	240	3-6

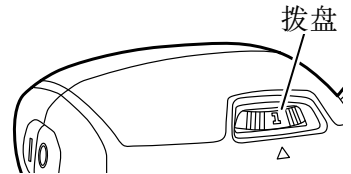
注：

请以此表中的数据为标准。

6. 确认开关处于 OFF 位置

注意！

安装或取出电池前，将开关处于 OFF 位置。

如果在开关处于 ON 位置时插入电池，电机将意外运行。

7. 检查电池插入情况

注意！

直至随着咔嗒一声电池锁定到位，否则，电池可能会意外地从工具中掉出，对您或周围人造成伤害。

操作

警告！

若发生以下情况，请务必先关掉开关，再从工具中取出电池：

- 停止或结束工作时
- 安装或拆卸附件或选购部件时
- 维护、检查或存放工具时

注意！

为延长使用期限，工具和锂离子电池配备停止输出的保护功能。因此，若工具超过负荷，电机也会停止。然而，这并非故障问题，而是保护功能起作用的结果。在这种情况下，请松开工具的开关，试着消除超过负荷的原因。

另请参阅“锂离子电池使用注意事项”。若仍无法运行，请向 HiKOKI 授权的维修中心请求维修。

警告！

打磨时切勿喷水或磨削液。否则会招致触电。

1. 如何握持盘式轨道砂光机

如图 11 所示，在抓住机壳的同时，将砂光机轻轻抵住要打磨的表面，使砂纸均匀接触打磨面。打磨时切勿对砂光机用力过猛。否则会导致电动机过载，砂纸使用寿命降低，以及打磨或抛光效率低下。



图 11

2. 如何移动盘式轨道砂光机

砂光机可以来回移动或沿一侧逐渐转圈移动（图 12 和图 13）。

3. 启动和关闭砂光机

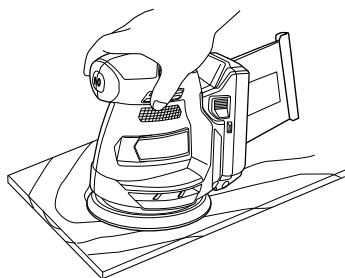
将开关设置为 ON (I) 可打开电源，将控制杆设置为 OFF (O) 可关闭电源。

注：

切勿在砂光机接触打磨面时打开电源开关。这可保护材料免受损坏。关闭电源时同样如此。



图 12

注意！

- 刚使用后，请务必确保开关处于 OFF 位置，并取出电池。
- 由于砂光机可能会吸入粉尘和切屑，因此在砂光机使用后仍在旋转时，勿将其放置在粉尘和切屑较多的地方。
- 俯看时，打磨垫板在负载运行时顺时针旋转，但在空载运行时可能会逆时针旋转。
- 切勿在无砂纸时运行工具。否则可能会严重损坏垫板。
- 在垫板边缘接触工件时使用工具可能会损坏垫板。

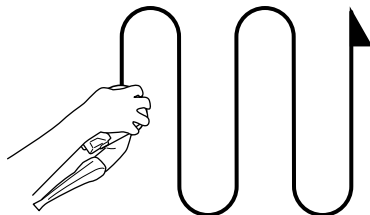

图 13

注：

安装新砂纸之后，由于其颗粒新且粗糙，因此砂光机的移动可能会变得不稳定。这可通过在打磨或抛光时略微向前或向后倾斜砂光机予以避免。砂光机的移动在砂纸适当研磨之后将变得稳定。

如何安装所选附件

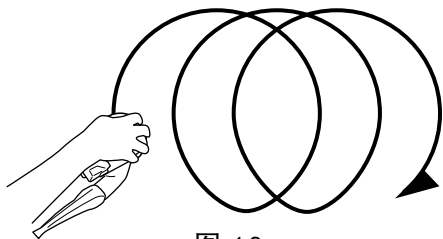
警告！

为避免发生严重事故，请确保开关处于关闭位置，并取出电池。

安装聚酯革或抛光海绵。

作为附件的聚酯革或抛光海绵与砂纸一样，属于钩环型安装，因此只需将其按压到垫板上即可（图 14）。



图 14

安装集尘器装置

外部抽取系统：

连接适当的抽取装置。

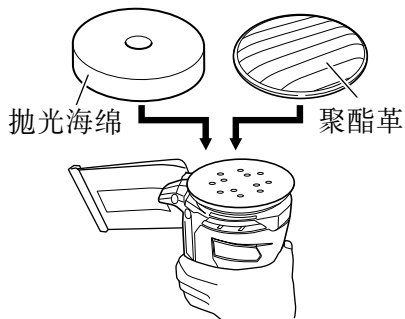
如有必要，请使用带真空适配器（A）或（B）的吸管。



图 15

维护和检查

警告！

检查或维护前，请务必关闭开关并取出电池。

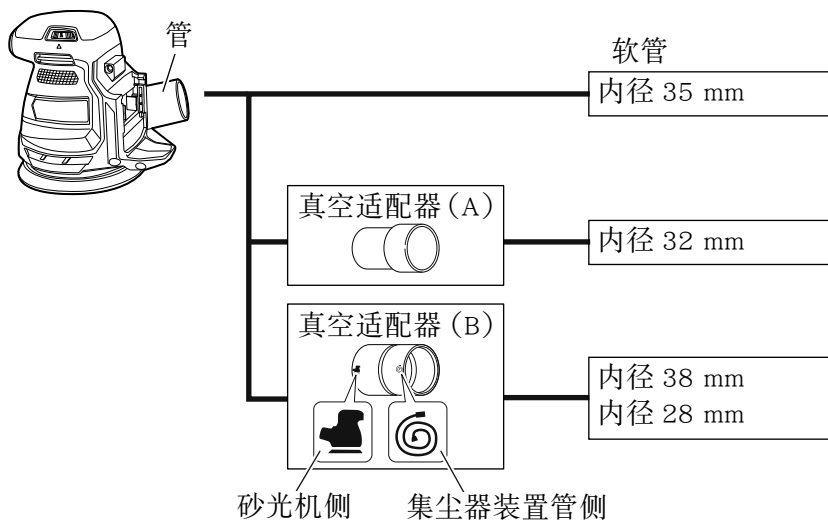
1. 倒空和清扫粉尘袋（图 16）

粉尘袋里的粉尘过多时，砂光机的集尘效果将会降低。所以，当粉尘袋里的粉尘满了时，请将粉尘袋倒空。

取下粉尘袋，拆下封口条并倒掉内容物。

2. 检查砂纸

如继续使用磨损了的砂纸，会降低工作效率，并可能磨损砂纸垫板，所以砂纸一旦出现磨损就请及时更换。

3. 检查安装螺钉

要经常检查安装螺钉是否紧固妥善。若发现螺钉松了，应立即重新扭紧，否则会导致严重的事故。

4. 电动机的维护

电动机绕线是电动工具的“心脏部”。

应仔细检查有无损伤，是否被油液或水沾湿。

5. 检查端子（工具和电池）

确保端子上没有堆积削屑和灰尘。

在操作前、操作时和操作后需要时常检查。



图 16

注意！

请清除端子上的削屑或灰尘。

否则可能导致故障。

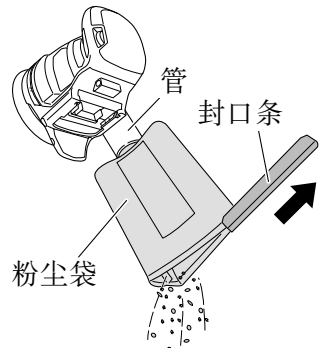
6. 查看灰尘

警告！

为防止吸入灰尘或刺激眼睛，使用气枪清洁时，请佩戴好安全护目镜和防尘面罩。

使用气枪或其他类似工具清除粘附在机身上的材料、碎屑等，并用柔软的干布或蘸有肥皂水的布擦拭。

请勿使用漂白剂、氯、汽油或稀释剂，因为可能会损坏塑料。

中文

7. 电力耗尽的电池的处理方法

警告！

请勿将电力耗尽的电池丢弃。如果焚烧电池，可能会引起爆炸。该电池可回收利用。根据各国家和地区的法令法规，将电力耗尽的电池丢弃到城市垃圾中属于违法行为。请向当地的固体废弃物负责人员咨询具体回收事宜或妥善的处理方法。

8. 收藏

请将电动工具存放在温度低于 40°C 且儿童无法触及的环境下。

注：

存放锂离子电池

在存放前请确保电池已完全充电。

电池在低电量的状态下长时间存放（3 个月或更长），可能会导致电池性能劣化，使用时间明显减少或无法进行充电。

但是，即使是使用时间明显减少的电池，通过反复充电和使用 2~5 次，有时也可恢复使用时间。

若反复充电和使用后电池的使用时间仍非常短，请认作为电池已达到了使用寿命并更换新的电池。

注意！

在操作和维修电动工具时，必须遵守贵国制定的安全的有关规则 and 标准。

关于 HiKOKI 牌无线电动工具的重要通知：

请确保始终使用我们指定的正版电池。如果使用我们指定以外的电池，或对电池进行拆卸和改动（例如拆卸和更换电池组件或其他内部部件），那么我们无法保证我们无线电动工具的安全性和使用性能。

选择附件

有关详细信息请联系 HIKOKI 授权服务中心。

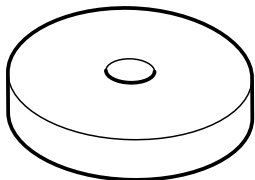
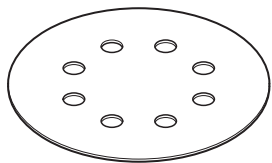

312518

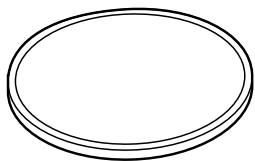

308515

A-P40	308516
A-P60	308517
A-P80	308518
A-P120	308519
A-P180	308520
A-P240	308521
A-P320	308522
A-P400	308523

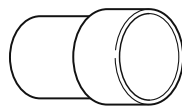

378837

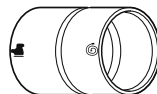

378838

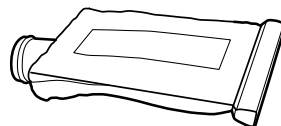

378842

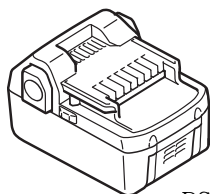

BSL18..

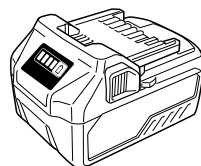
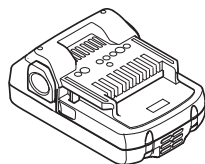

BSL36..18

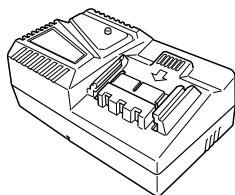
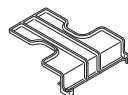
UC18YFSL
(14.4V - 18V)

329897

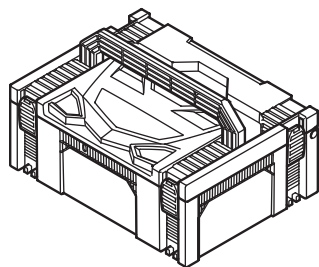

336471

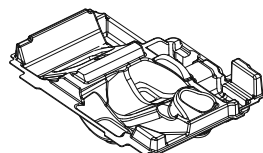

378839

CONTENTS

GENERAL POWER TOOL SAFETY WARNINGS	22
CORDLESS RANDOM ORBIT SANDER SAFETY WARNINGS	25
ADDITIONAL SAFETY WARNINGS	25
CAUTION ON LITHIUM-ION BATTERY	27
REGARDING LITHIUM-ION BATTERY TRANSPORTATION	29
SYMBOLS	29
NAME OF PARTS	30
SPECIFICATIONS	30
STANDARD ACCESSORIES	31
APPLICATIONS	31
BATTERY REMOVAL/INSTALLATION	32
CHARGING	32
PRIOR TO OPERATION	35
OPERATION	37
HOW TO INSTALL THE SELECTING ACCESSORIES	39
ATTACHING THE DUST COLLECTOR	39
MAINTENANCE AND INSPECTION	40
SELECTING ACCESSORIES	42

GENERAL POWER TOOL SAFETY WARNINGS

WARNING

Read all safety warnings, instructions, illustrations and specifications provided with this power tool.

Failure to follow all instructions listed below may result in electric shock, fire and/or serious injury.

Save all warnings and instructions for future reference.

The term “power tool” in the warnings refers to your mains-operated (corded) power tool or battery-operated (cordless) power tool.

- 1) **Work area safety**
 - a) **Keep work area clean and well lit.**
Cluttered or dark areas invite accidents.
 - b) **Do not operate power tools in explosive atmospheres, such as in the presence of flammable liquids, gases or dust.**
Power tools create sparks which may ignite the dust or fumes.
 - c) **Keep children and bystanders away while operating a power tool.**
Distractions can cause you to lose control.
- 2) **Electrical safety**
 - a) **Power tool plugs must match the outlet.**
Never modify the plug in any way.
Do not use any adapter plugs with earthed (grounded) power tools.
Unmodified plugs and matching outlets will reduce risk of electric shock.

- b) **Avoid body contact with earthed or grounded surfaces, such as pipes, radiators, ranges and refrigerators.**
There is an increased risk of electric shock if your body is earthed or grounded.
- c) **Do not expose power tools to rain or wet conditions.**
Water entering a power tool will increase the risk of electric shock.
- d) **Do not abuse the cord. Never use the cord for carrying, pulling or unplugging the power tool.**
Keep cord away from heat, oil, sharp edges or moving parts.
Damaged or entangled cords increase the risk of electric shock.
- e) **When operating a power tool outdoors, use an extension cord suitable for outdoor use.**
Use of a cord suitable for outdoor use reduces the risk of electric shock.
- f) **If operating a power tool in a damp location is unavoidable, use a residual current device (RCD) protected supply.**
Use of an RCD reduces the risk of electric shock.

3) Personal safety

- a) **Stay alert, watch what you are doing and use common sense when operating a power tool.**
Do not use a power tool while you are tired or under the influence of drugs, alcohol or medication.
A moment of inattention while operating power tools may result in serious personal injury.
- b) **Use personal protective equipment. Always wear eye protection.**
Protective equipment such as a dust mask, non-skid safety shoes, hard hat or hearing protection used for appropriate conditions will reduce personal injuries.
- c) **Prevent unintentional starting. Ensure the switch is in the off-position before connecting to power source and/or battery pack, picking up or carrying the tool.**
Carrying power tools with your finger on the switch or energising power tools that have the switch on invites accidents.
- d) **Remove any adjusting key or wrench before turning the power tool on.**
A wrench or a key left attached to a rotating part of the power tool may result in personal injury.
- e) **Do not overreach. Keep proper footing and balance at all times.**
This enables better control of the power tool in unexpected situations.
- f) **Dress properly. Do not wear loose clothing or jewellery. Keep your hair, clothing and gloves away from moving parts.**
Loose clothes, jewellery or long hair can be caught in moving parts.
- g) **If devices are provided for the connection of dust extraction and collection facilities, ensure these are connected and properly used.**
Use of dust collection can reduce dust-related hazards.
- h) **Do not let familiarity gained from frequent use of tools allow you to become complacent and ignore tool safety principles.**
A careless action can cause severe injury within a fraction of a second.

English

4) Power tool use and care

- a) **Do not force the power tool. Use the correct power tool for your application.**
The correct power tool will do the job better and safer at the rate for which it was designed.
- b) **Do not use the power tool if the switch does not turn it on and off.**
Any power tool that cannot be controlled with the switch is dangerous and must be repaired.
- c) **Disconnect the plug from the power source and/or remove the battery pack, if detachable, from the power tool before making any adjustments, changing accessories, or storing power tools.**
Such preventive safety measures reduce the risk of starting the power tool accidentally.
- d) **Store idle power tools out of the reach of children and do not allow persons unfamiliar with the power tool or these instructions to operate the power tool.**
Power tools are dangerous in the hands of untrained users.
- e) **Maintain power tools and accessories. Check for misalignment or binding of moving parts, breakage of parts and any other condition that may affect the power tool's operation.**
If damaged, have the power tool repaired before use.
Many accidents are caused by poorly maintained power tools.
- f) **Keep cutting tools sharp and clean.**
Properly maintained cutting tools with sharp cutting edges are less likely to bind and are easier to control.
- g) **Use the power tool, accessories and tool bits etc. in accordance with these instructions, taking into account the working conditions and the work to be performed.**
Use of the power tool for operations different from those intended could result in a hazardous situation.
- h) **Keep handles and grasping surfaces dry, clean and free from oil and grease.**
Slippery handles and grasping surfaces do not allow for safe handling and control of the tool in unexpected situations.

5) Battery tool use and care

- a) **Recharge only with the charger specified by the manufacturer.**
A charger that is suitable for one type of battery pack may create a risk of fire when used with another battery pack.
- b) **Use power tools only with specifically designated battery packs.**
Use of any other battery packs may create a risk of injury and fire.
- c) **When battery pack is not in use, keep it away from other metal objects, like paper clips, coins, keys, nails, screws or other small metal objects, that can make a connection from one terminal to another.**
Shorting the battery terminals together may cause burns or a fire.
- d) **Under abusive conditions, liquid may be ejected from the battery; avoid contact. If contact accidentally occurs, flush with water. If liquid contacts eyes, additionally seek medical help.**
Liquid ejected from the battery may cause irritation or burns.

- e) **Do not use a battery pack or tool that is damaged or modified.**
Damaged or modified batteries may exhibit unpredictable behaviour resulting in fire, explosion or risk of injury.
 - f) **Do not expose a battery pack or tool to fire or excessive temperature.**
Exposure to fire or temperature above 130 °C may cause explosion.
 - g) **Follow all charging instructions and do not charge the battery pack or tool outside the temperature range specified in the instructions.**
Charging improperly or at temperatures outside the specified range may damage the battery and increase the risk of fire.
- 6) **Service**
- a) **Have your power tool serviced by a qualified repair person using only identical replacement parts.**
This will ensure that the safety of the power tool is maintained.
 - b) **Never service damaged battery packs.**
Service of battery packs should only be performed by the manufacturer or authorized service providers.

CAUTION

Keep children and infirm persons away.

When not in use, tools should be stored out of reach of children and infirm persons.

CORDLESS RANDOM ORBIT SANDER SAFETY WARNINGS

1. **Hold tools by insulated gripping surfaces when performing an operation where the cutting tool may contact hidden wiring.** Contact with a “live” wire will make exposed metal parts of the tool “live” and shock the operator.

ADDITIONAL SAFETY WARNINGS

1. **Use clamps or another practical way to secure and support the workpiece to a stable platform.**
Holding the workpiece by hand or against your body leaves it unstable and may lead to loss of control.
2. **Attaching and removing the dust bag**
Prior to the sanding operation, make sure the material of surface you are going to sand.
If the surface under sanding operation is expected to generate harmful / toxic dusts such as lead painted surface, make sure the dust bag or appropriate dust extraction system is connected with dust outlet tightly.
Wear the dust mask additionally, if available.
Do not inhale or touch the harmful / toxic dusts generated in sanding operation, the dust can endanger the health of yourself and bystanders.
3. **Never apply water or grinding fluid when sanding.** This could result in electrical shock.

English

4. Never turn the power switch ON when the sander is contacting the surface to be sanded. This is necessary to preclude damage to the material. The same applies when switching the power OFF.
5. DO NOT apply excessive pressure to the sander while sanding. Excessive-pressure may cause overload of the motor, reduced service life of the sanding paper, and lowered sanding or polishing efficiency.
6. Never touch moving parts.
Never place your hands, fingers or other body parts near the tool's moving parts.
7. NEVER leave tool running unattended. Turn power off. Don't leave tool until it comes to a complete stop.
8. When operating the tool, do not wear work gloves as such cloth wear can get caught in the tool.
9. Do not leave the tool running. Operate the tool only when hand-held.
10. Make sure that there are no cracks, scratches, or other abnormalities on the pad before use.
11. Accessories must be securely mounted to the tool.
Prevent potential injuries to yourself or others. Accessories which have been mounted to the tool should be secure and tight.
12. Use the sanding paper and accessories specified by HiKOKI.
13. When sanding metal, sparks are generated. Do not use the dust bag, and keep other persons and flammable substances away from the work area.
14. If you notice that the unit is generating unusually high temperatures, operating poorly, or making abnormal noises, immediately stop using and shut off the power switch. Request an inspection and repair from the dealer where you purchased the unit or a HiKOKI Authorized Service Center.
Continuing to use while operating abnormally might cause injuries.
15. If the unit is mistakenly dropped or strikes another object, make a thorough check of the unit for cracks, breakage or deformation, etc.
Injuries might occur if the unit has cracks, breakage or deformation.
16. When working at elevated locations, clear the area of other people and aware of conditions below you.
17. Always charge the battery at a temperature of 0–40°C.
A temperature of less than 0°C will result in over charging which is dangerous. The battery cannot be charged at a temperature greater than 40°C.
The most suitable temperature for charging is that of 20–25°C.
18. Do not use the charger continuously.
When one charging is completed, leave the charger for about 15 minutes before the next charging of battery.
19. Do not allow foreign matter to enter the hole for connecting the rechargeable battery.
20. Never disassemble the rechargeable battery and charger.
21. Never short-circuit the rechargeable battery. Shortcircuiting the battery will cause a great electric current and overheat. It results in burn or damage to the battery.
22. Do not dispose of the battery in fire. If the battery is burnt, it may explode.

23. Bring the battery to the shop from which it was purchased as soon as the post-charging battery life becomes too short for practical use. Do not dispose of the exhausted battery.
24. Do not insert object into the air ventilation slots of the charger. Inserting metal objects or inflammables into the charger air ventilation slots will result in electrical shock hazard or damaged charger.
25. When using this unit continuously, the unit may overheat, leading to damage in the motor and switch. Therefore, whenever the housing becomes hot, give the tool a break for a while.
26. Make sure that the battery is installed firmly. If it is at all loose it could come off and cause an accident.
27. Do not use the product if the tool or the battery terminals (battery mount) are deformed.
Installing the battery could cause a short circuit that could result in smoke emission or ignition.
28. Keep the tool's terminals (battery mount) free of swarf and dust.
 - Prior to use, make sure that swarf and dust have not collected in the area of the terminals.
 - During use, try to avoid swarf or dust on the tool from falling on the battery.
 - When suspending operation or after use, do not leave the tool in an area where it may be exposed to falling swarf or dust.
Doing so could cause a short circuit that could result in smoke emission or ignition.
29. Always use the tool and battery at temperatures between -5°C and 40°C.

CAUTION ON LITHIUM-ION BATTERY

To extend the lifetime, the lithium-ion battery equips with the protection function to stop the output.

In the cases of 1 to 3 described below, when using this product, even if you are pulling the switch, the motor may stop. This is not the trouble but the result of protection function.

1. When the battery power remaining runs out, the motor stops.
In such case, charge it up immediately.
2. If the tool is overloaded, the motor may stop. In this case, release the switch of tool and eliminate causes of overloading. After that, you can use it again.
3. If the battery is overheated under overload work, the battery power may stop.
In this case, stop using the battery and let the battery cool. After that, you can use it again.

Furthermore, please heed the following warning and caution.

WARNING

In order to prevent any battery leakage, heat generation, smoke emission, explosion and ignition beforehand, please be sure to heed the following precautions.

1. Make sure that swarf and dust do not collect on the battery.
 - During work make sure that swarf and dust do not fall on the battery.
 - Make sure that any swarf and dust falling on the power tool during work do not collect on the battery.
 - Do not store an unused battery in a location exposed to swarf and dust.

English

- Before storing a battery, remove any swarf and dust that may adhere to it and do not store it together with metal parts (screws, nails, etc.).
2. Do not pierce battery with a sharp object such as a nail, strike with a hammer, step on, throw or subject the battery to severe physical shock.
3. Do not use an apparently damaged or deformed battery.
4. Do not use the battery for a purpose other than those specified.
5. If the battery charging fails to complete even when a specified recharging time has elapsed, immediately stop further recharging.
6. Do not put or subject the battery to high temperatures or high pressure such as into a microwave oven, dryer, or high pressure container.
7. Keep away from fire immediately when leakage or foul odor are detected.
8. Do not use in a location where strong static electricity generates.
9. If there is battery leakage, foul odor, heat generated, discolored or deformed, or in any way appears abnormal during use, recharging or storage, immediately remove it from the equipment or battery charger, and stop use.
10. Do not immerse the battery or allow any fluids to flow inside. Conductive liquid ingress, such as water, can cause damage resulting in fire or explosion. Store your battery in a cool, dry place, away from combustible and flammable items. Corrosive gas atmospheres must be avoided.

CAUTION

1. If liquid leaking from the battery gets into your eyes, do not rub your eyes and wash them well with fresh clean water such as tap water and contact a doctor immediately. If left untreated, the liquid may cause eye-problems.
2. If liquid leaks onto your skin or clothes, wash well with clean water such as tap water immediately.
There is a possibility that this can cause skin irritation.
3. If you find rust, foul odor, overheating, discolor, deformation, and/or other irregularities when using the battery for the first time, do not use and return it to your supplier or vendor.

WARNING

If a conductive foreign matter enters in the terminal of lithium ion battery, the battery may be shorted, causing fire. When storing the lithium ion battery, obey surely the rules of following contents.

- Do not place conductive debris, nail and wires such as iron wire and copper wire in the storage case.
- To prevent shorting from occurring, load the battery in the tool or insert securely the battery cover for storing until the ventilator is not seen (See Fig. 1).

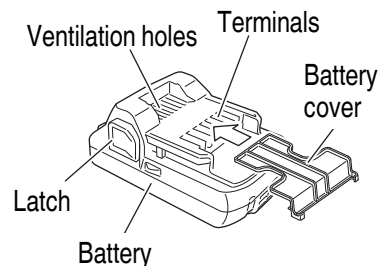

Fig. 1

REGARDING LITHIUM-ION BATTERY TRANSPORTATION

When transporting a lithium-ion battery, please observe the following precautions.

WARNING

Notify the transporting company that a package contains a lithium-ion battery, inform the company of its power output and follow the instructions of the transportation company when arranging transport.

- Lithium-ion batteries that exceed a power output of 100 Wh are considered to be in the freight classification of Dangerous Goods and will require special application procedures.
- For transportation abroad, you must comply with international law and the rules and regulations of the destination country.

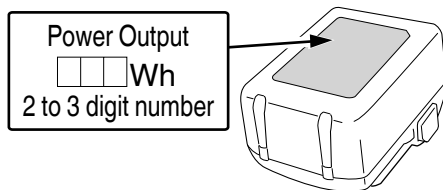





Fig. 2

SYMBOLS

WARNING

The following show symbols used for the machine. Be sure that you understand their meaning before use.

	To reduce the risk of injury, user must read instruction manual.	n_0	No-load speed
	Direct current	/min	Oscillation per minute
V	Rated voltage		Warning

NAME OF PARTS

1. POWER TOOL

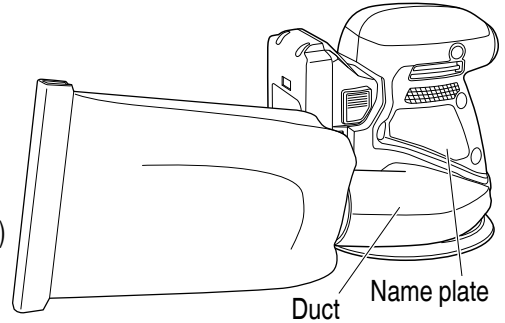
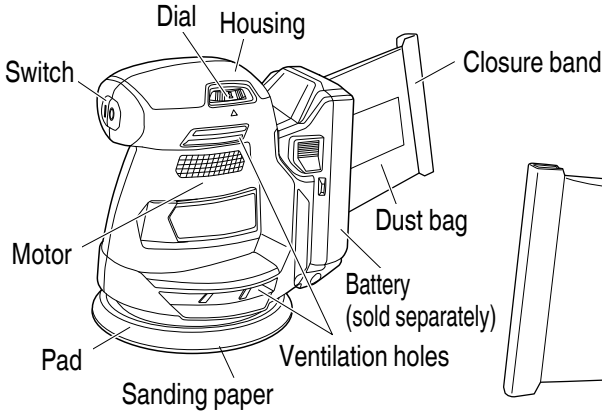
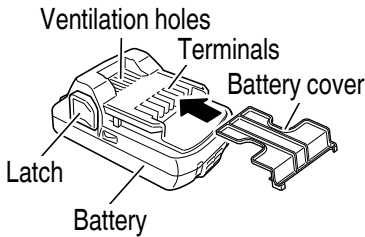

Fig. 3

2. Battery (Optional accessories)



<BSL1830C>

Fig. 4

3. Battery Charger (Optional accessories)

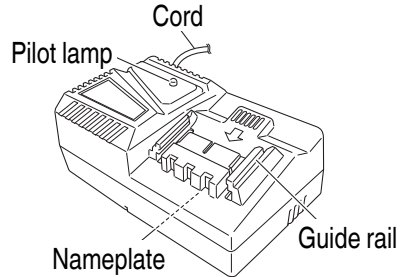

<UC18YFSL>

Fig. 5

SPECIFICATIONS

Model	SV1813DA
Voltage	18 V
No-load speed	7000-11000 /min
Sanding pad size (Outer diameter)	125 mm
Sanding paper size (Outer diameter)	125 mm
Battery	BSL1830C: Li-ion 18 V (3.0 Ah, 5 cells)
Weight	1.6 kg (BSL1830C attached)

Electronic control

Braking Function

Brake is activated when the switch is turned off, stopping the motor's rotation.



CHARGER (Sold separately)

Model	UC18YFSL
Charging voltage	14.4 V-18 V
Weight	0.5 kg

STANDARD ACCESSORIES

In addition to the main unit (1 unit), the package contains the accessories listed in the below.

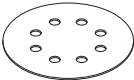
Table 1

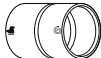
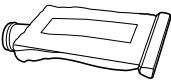
		SV1813DA (NN)
Sanding paper		1
Vacuum adapter (A)		1
Vacuum adapter (B)		1
Dust bag		1

APPLICATIONS

- Roughing or finishing of woodwork and metal surfaces.
- Preliminary sanding of woodwork and metal surfaces before painting.
- Paint removal.
- Rust removal.

BATTERY REMOVAL/INSTALLATION

1. Battery removal
Hold the handle tightly and push the battery latches to remove the battery (see **Fig. 6**).

CAUTION

Never short-circuit the battery.

2. Battery installation
Insert the battery while observing its polarities (See **Fig. 6**).

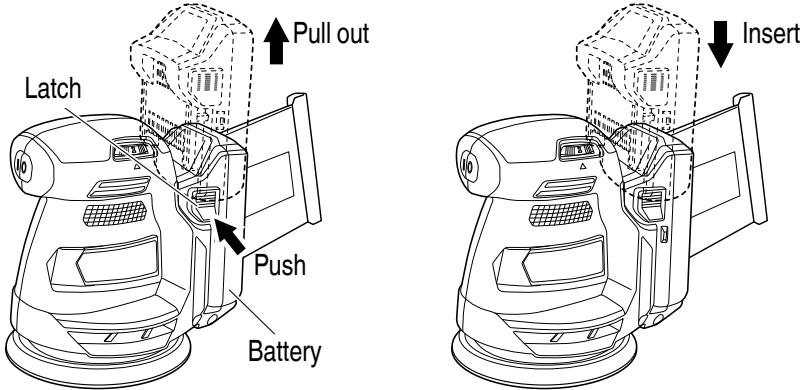

Fig. 6

CHARGING

Before using the power tool, charge the battery as follows.

1. Connect the charger's power cord to the receptacle.
When connecting the plug of the charger to a receptacle, the pilot lamp will blink in red (At 1-second intervals).
2. Insert the battery into the charger.
Firmly insert the battery into the charger as shown in **Fig. 7**.
3. Charging
When inserting a battery in the charger, charging will commence and the pilot lamp will light continuously in red.
When the battery becomes fully recharged, the pilot lamp will blink in red. (At 1-second intervals) (See **Table 2**)

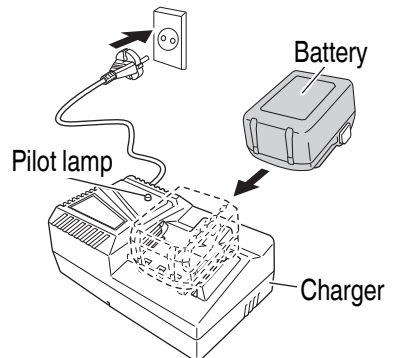

Fig. 7

English

CAUTION

When the battery charger has been continuously used, the battery charger will be heated, thus constituting the cause of the failures. Once the charging has been completed, give 15 minutes rest until the next charging.

4. Disconnect the charger's power cord from the receptacle.
5. Hold the charger firmly and pull out the battery.

NOTE

Be sure to pull out the battery from the charger after use, and then keep it.

Regarding electric discharge in case of new batteries, etc.

As the internal chemical substance of new batteries and batteries that have not been used for an extended period is not activated, the electric discharge might be low when using them the first and second time. This is a temporary phenomenon, and normal time required for recharging will be restored by recharging the batteries 2–3 times.

How to make the batteries perform longer.

- (1) Recharge the batteries before they become completely exhausted.
When you feel that the power of the tool becomes weaker, stop using the tool and recharge its battery. If you continue to use the tool and exhaust the electric current, the battery may be damaged and its life will become shorter.
- (2) Avoid recharging at high temperatures.
A rechargeable battery will be hot immediately after use. If such a battery is recharged immediately after use, its internal chemical substance will deteriorate, and the battery life will be shortened. Leave the battery and recharge it after it has cooled for a while.

CAUTION

- **If the battery is charged while it is heated because it has been left for a long time in a location subject to direct sunlight or because the battery has just been used, the pilot lamp of the charger lights for 1 second, does not light for 0.5 seconds (off for 0.5 seconds). In such a case, first let the battery cool, then start charging.**
- **When the pilot lamp flickers (at 0.2-second intervals), check for and take out any foreign objects in the charger's battery connector. If there are no foreign objects, it is probable that the battery or charger is malfunctioning. Take it to your authorized Service Center.**
- **If the pilot lamp does not blink in red (every second) even though the charger cord is connected to the power, it indicates that the protection circuit of the charger may be activated.**

Remove the cord or plug from the power and then connect it again after 30 seconds or so. If this does not cause the pilot lamp to blink in red (every second), please take the charger to the HiKOKI Authorized Service Center.

PRIOR TO OPERATION

WARNING

To avoid serious accident, ensure the switch is in the OFF position, and pull out the battery.

1. Check the work area environment
Check the work area to make sure that it is clear of debris and clutter.
Clear the area of unnecessary personnel. Ensure that lighting and ventilation is adequate.
2. Power switch
Ensure that the power switch is in the OFF position.
3. Installing the sanding paper

CAUTION

- Use only sanding paper size specified on the product nameplate.
- Do not use accessories with poor adhesion.

Since the attachment is a hook-and-loop type, the sanding paper can be installed easily by just pressing it onto the pad.

- (1) Gently pinch and hold together two places on the edges of the sanding paper so that two holes are visible on the bottom. (**Fig. 8-a**)
- (2) Overlap the two holes of the sanding paper with two holes of the pad, and attach the whole surface of the sanding paper to the pad so that the remaining holes are also aligned. (**Fig. 8-b**)

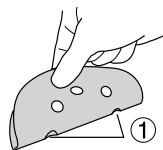

Fig. 8-a Hold the sanding paper so that two of its holes are visible on the bottom

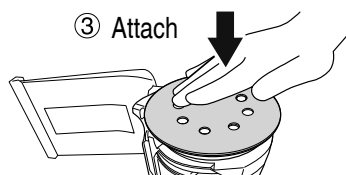
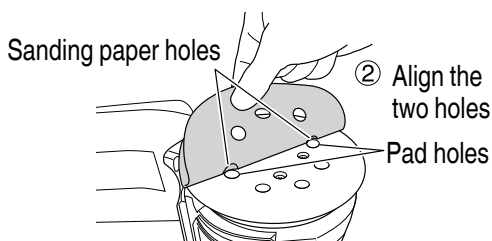

Fig. 8-b

English

4. Attaching and Removing the dust bag (Fig. 9)

- (1) Attaching the dust bag
Insert the dust bag into the duct on the body of the power tool.
- (2) Removing the dust bag
Hold the duct, and pull out the dust bag.

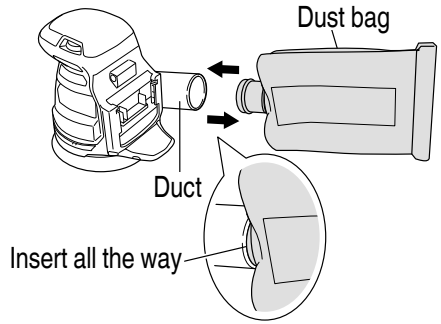

Fig. 9

WARNING

Prior to the sanding operation, make sure the material of surface you are going to sand.

If the surface under sanding operation is expected to generate harmful / toxic dusts such as lead painted surface, make sure the dust bag or appropriate dust extraction system is connected with dust outlet tightly.

Wear the dust mask additionally, if available.

Do not inhale or touch the harmful / toxic dusts generated in sanding operation, the dust can endanger the health of yourself and bystanders.

CAUTION

If too much dust accumulates in the dust bag, the dust collection power will be reduced. Dispose of dust as soon as possible.

5. Adjustment of speed

The sander is equipped with an electric control circuit that enables speed control. To adjust the speed, turn the dial shown in Fig. 10. When the dial is set to "1", the sander operates at the minimum speed (7000 min). When the dial set to "6", the sander operates at the maximum speed (11000 min). Adjust the speed according to the material to be cut and working efficiency.

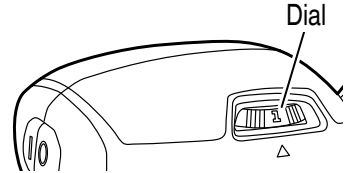

Fig. 10

Table 4 By adjusting the dial, match the speed to the material and type of work.

Material	Grain		Dial scale
	Rough grinding	Fine grinding	
Paintwork: Sanding	180	400	3-6
Repairs (scratches, rust spots)	120	240	2-4
Stripping	40	80	2-4
Wood: Softwood	60-80	240	3-6
Hardwood	60	180	3-5
Veneers	240	320	2-4
Metals: Aluminium	80	240	2-4
Steel	60	240	3-6
Stainless steel	120	240	3-6

NOTE

Please use this table as a standard.

6. Confirm the switch is in OFF position

CAUTION

Before installing or removing the battery, turn the switch to the OFF position.

If the battery is inserted with the switch in the ON position, the motor will operate unexpectedly.

7. Check battery insertion

CAUTION

Until the battery locks in place with a little click, if not, it may accidentally fall out of the tool causing injury to you or someone around you.

OPERATION**WARNING**

Be sure to turn off the switch, then remove the battery from the tool in the following situations:

- When stopping or ending work
- When attaching or removing accessories or optional parts
- When maintaining, inspecting, or storing the tool

English

CAUTION

To extend the lifetime, the tool and the lithium-ion battery are equipped with a protection function to stop the output. Therefore, if the tool is overloaded, the motor may stop. However, this is not the trouble but the result of protection function. In this case, release the switch of tool and eliminate the causes of overloading. Additionally, refer to “CAUTION ON LITHIUM-ION BATTERY”. If it still does not run, request repairs from a HiKOKI authorized service center.

WARNING

Never apply water or grinding fluid when sanding. This could result in electrical shock.

1. How to hold the random orbit sander
While gripping the housing, lightly press the sander against the surface to be sanded so that the sanding paper uniformly contacts the surface, as shown in **Fig. 11**. DO NOT apply excessive pressure to the sander while sanding. Excessive-pressure may cause overload of the motor, reduced service life of the sanding paper, and lowered sanding or polishing efficiency.
2. How to move the random orbit sander
Move the sander by either moving it up and down or by moving it in circles while gradually progressing in a sideways direction (**Figs. 12 and 13**).
3. Switching the sander ON and OFF
The power can be turned on by setting the switch to ON (I) and turned off by setting the lever to OFF (O).

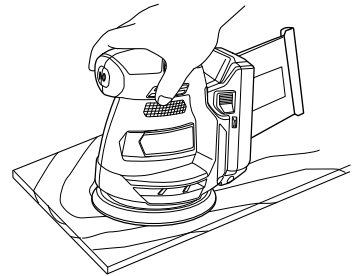

Fig. 11

NOTE

Never turn the power switch ON when the sander is contacting the surface to be sanded. This is necessary to preclude damage to the material. The same applies when switching the power OFF.

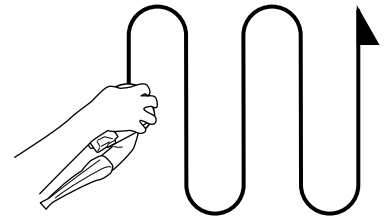

Fig. 12

CAUTION

- Immediately after use, always ensure that the switch is in the OFF position and pull out the battery.
- Since the sander may suck in dust and debris, be careful not to place it where there is much dust and debris when it is still spinning right after use.
- Looking from above, the sanding pad rotates clockwise during the loaded operation, but it may rotate counterclockwise during the no-load operation.

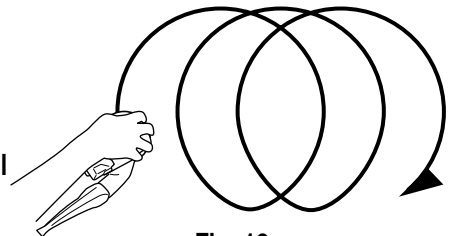

Fig. 13

- Never run the tool without the sanding paper. You may seriously damage the pad.
- Using the tool with the pad edge contacting the workpiece may damage the pad.

NOTE

Movement of the sander may tend to become unsteady after new sanding paper has been installed, because of the new, coarse grain of the paper. This can be avoided by slightly tilting the sander forward or backward during sanding or polishing. Sander movement will become steady as the sanding paper surface becomes properly abraded.

HOW TO INSTALL THE SELECTING ACCESSORIES

WARNING

To avoid serious accident, ensure the switch is in the OFF position, and pull out the battery.

Installing the polyester buff or the polishing sponge.
Since the attachment is a hook-and-loop type as with the sanding paper, the polyester buff or the polishing sponge can be mounted by just pressing it onto the pad (Fig. 14).

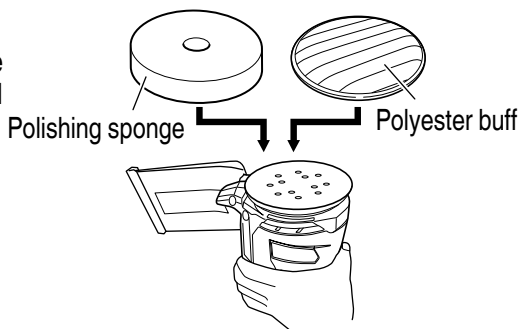

Fig. 14

ATTACHING THE DUST COLLECTOR

External extraction system:

Connect a suitable extraction device.

Use a suction hose with vacuum adapter (A) or (B) if necessary.

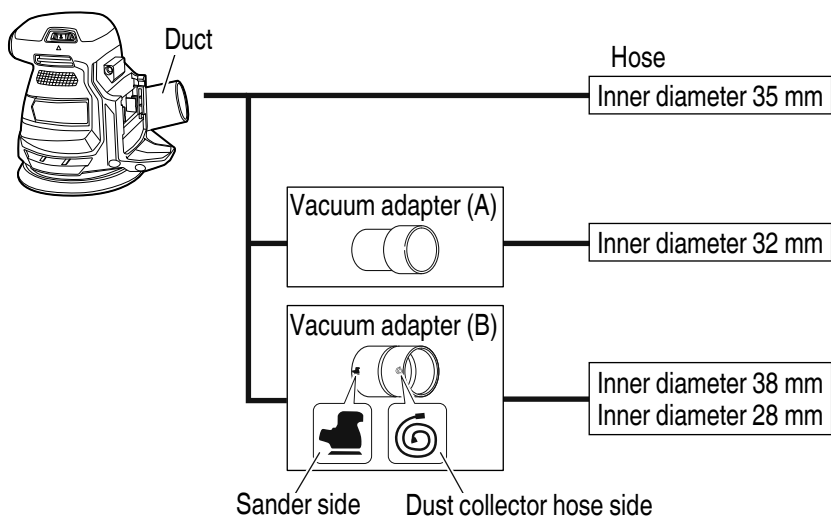

Fig. 15

MAINTENANCE AND INSPECTION

WARNING

Be sure to turn off the switch and pull out the battery before doing any inspection or maintenance.

1. **Emptying and cleaning the dust bag (Fig. 16)**
If the dust bag contains too much dust, dust collection will be affected. Empty the dust bag when it gets full. Remove the dust bag, detach the closure band and dispose of the contents.
2. **Inspecting the sanding paper**
Since use of worn-out sanding paper will degrade efficiency and cause possible damage to the pad, replace the sanding paper as soon as excessive abrasion is noted.
3. **Inspecting the mounting screws**
Regularly inspect all mounting screws and ensure that they are properly tightened. Should any of the screws be loose, retighten them immediately. Failure to do so could result in serious hazard.
4. **Maintenance of the motor**
The motor unit winding is the very "heart" of the power tool. Exercise due care to ensure the winding does not become damaged and/or wet with oil or water.
5. **Inspection of terminals (tool and battery)**
Check to make sure that swarf and dust have not collected on the terminals. On occasion check prior, during and after operation.

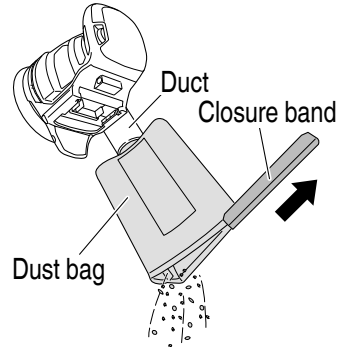

Fig. 16

CAUTION

Remove any swarf or dust which may have collected on the terminals. Failure to do so may result in malfunction.

6. Check for Dust

WARNING

To prevent dust inhalation or eye irritation, wear protective safety goggles and a dust mask when using an air gun to clean.

Use an air gun or other similar tool to remove materials, chips, etc. which have adhered to the body, and wipe with a soft dry cloth or a cloth moistened with soapy water. Do not use bleach, chlorine, gasoline or thinner, for they may damage the plastics.

7. Disposal of the exhausted battery

WARNING

Do not dispose of the exhausted battery. The battery may explode if it is incinerated. The battery is recyclable. At the end of its useful life, under various state and local laws, it may be illegal to dispose of this battery into the municipal waste stream. Check with your local solid waste officials for details in your area for recycling options or proper disposal.

8. Storage

Store the power tool in a place in which the temperature is less than 40°C, and out of reach of children.

NOTE

Storing Lithium-ion Batteries

Make sure the batteries have been fully charged before storing them.

Prolonged storage (3 months or more) of batteries with a low charge may result in performance deterioration, significantly reducing battery usage time or rendering the batteries incapable of holding a charge.

However, significantly reduced battery usage time may be recovered by repeatedly charging and using the batteries two to five times.

If the battery usage time is extremely short despite repeated charging and use, consider the batteries dead and purchase new batteries.

CAUTION

In the operation and maintenance of power tools, the safety regulations and standards prescribed in each country must be observed.

Important notice on the batteries for the HiKOKI cordless power tools

Please always use one of our designated genuine batteries. We cannot guarantee the safety and performance of our cordless power tool when used with batteries other than these designated by us, or when the battery is disassembled and modified (such as disassembly and replacement of cells or other internal parts).

SELECTING ACCESSORIES

For details contact HiKOKI Authorized Service Center.

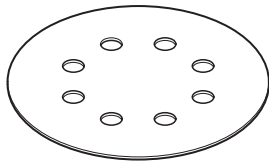

A-P40	308516
A-P60	308517
A-P80	308518
A-P120	308519
A-P180	308520
A-P240	308521
A-P320	308522
A-P400	308523

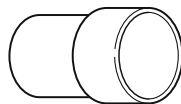

378837

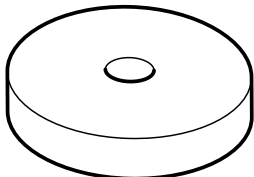

312518

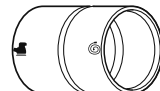

378838

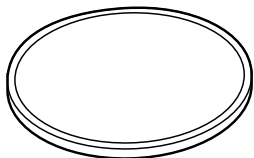

308515

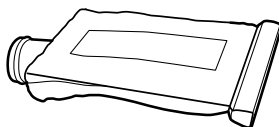

378842

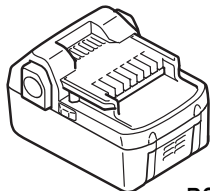

BSL18..

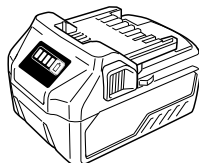
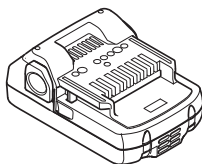

BSL36..18

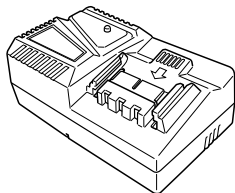

UC18YFSL (14.4 V-18 V)

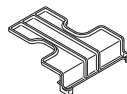

329897

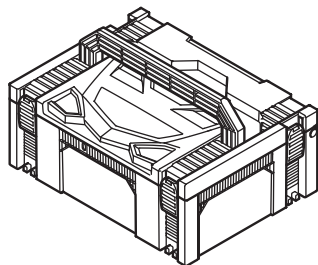

336471

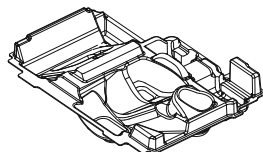

378839

产品中有害物质的名称及含量

部件名称	有害物质					
	铅 (Pb)	汞 (Hg)	镉 (Cd)	六价铬 (Cr(VI))	多溴联苯 (PBB)	多溴二苯醚 (PBDE)
外壳部件	○	○	○	○	○	○
电机部件	○	○	○	○	○	○
开关	×	○	○	○	○	○
电镀部件（钢叶片等）	○	○	○	○	○	○
传动部件（齿轮轴等）	○	○	○	○	○	○
电源部件 (电线、引线等)	○	○	○	○	○	○
各种螺丝	○	○	○	○	○	○
铜焊部件 (超硬锯片等)	○	○	○	○	○	○
其它机械部件 (金属件等)	○	○	○	○	○	○
润滑剂（润滑脂等）	○	○	○	○	○	○
充电器	×	○	○	○	○	○
电池	×	○	×	○	○	○

本表格依据 SJ/T 11364 的规定编制。

○：表示该有害物质在该部件所有均质材料中的含量均在 GB/T26572 规定的限量要求以下。

×：表示该有害物质至少在该部件的某一均质材料中的含量超出 GB/T26572 规定的限量要求。

服务中心
高壹工机商业(上海)有限公司
上海市闵行区浦江工业园区三鲁路3585号7幢3楼

制造商
广东高壹工机有限公司
广东省广州市番禺区化龙镇工业路富裕围工业村

Koki Holdings Co., Ltd.

201
编号: C99744221 G
发行日期: 2022年 1月
中国印刷