

HIKOKI

中文
English

电动锤钻
Rotary Hammer

DH 52MA

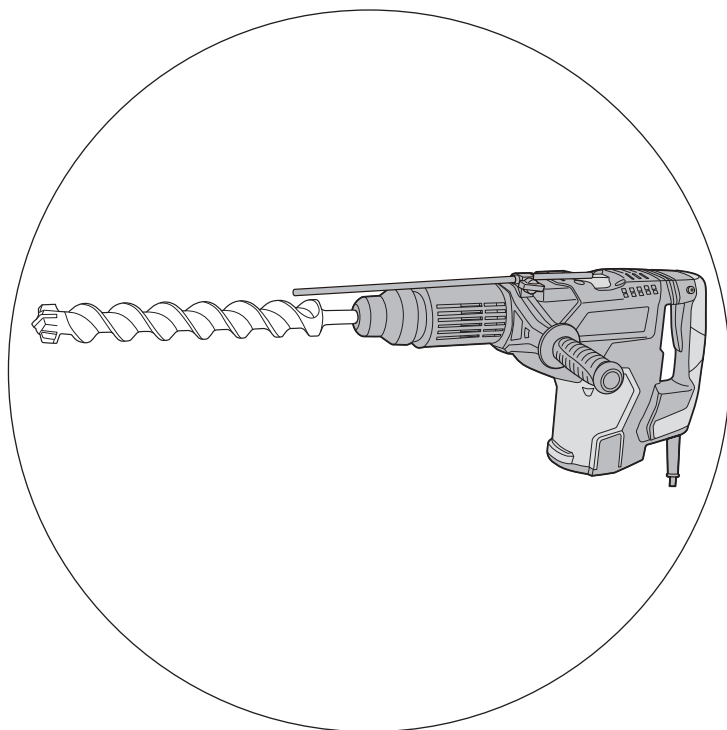

保留备用
Keep for future reference



使用说明书
Handling instructions



目次

电动工具通用安全警告	2	用途.....	8
电动锤钻安全警告.....	4	作业之前.....	9
其它安全警告.....	4	使用方法.....	11
符号.....	5	使用锤钻夹盘和夹盘附加器.....	13
规格.....	5	怎么样使用取心钻具.....	14
标准附件.....	5	更换润滑油.....	15
选购附件（分开销售）.....	6	维护和检查.....	15

电动工具通用安全警告

⚠ 警告！

阅读所有警告和所有说明。

不遵照以下警告和说明会导致电击、着火和 / 或严重伤害。

保存所有警告和说明书以备查阅。

在所有下列的警告中术语“电动工具”指市电驱动(有线)电动工具或电池驱动(无线)电动工具。

1) 工作场地的安全

- a) 保持工作场地清洁和明亮。
混乱和黑暗的场地会引发事故。
- b) 不要在易爆环境，如有易燃液体、气体或粉尘的环境下操作电动工具。
电动工具产生的火花会点燃粉尘或气体。
- c) 让儿童和旁观者离开后操作电动工具。
注意力不集中会使操作者失去对工具的控制。

2) 电气安全

- a) 电动工具插头必须与插座相配。绝不能以任何方式改装插头。
需接地的电动工具不能使用任何转换插头。
未经改装的插头和相配的插座将减少电击危险。
- b) 避免人体接触接地表面，如管道、散热片和冰箱。
如果你身体接地会增加电击危险。
- c) 不得将电动工具暴露在雨中或潮湿环境中。
水进入电动工具将增加电击危险。
- d) 不得滥用电线。绝不能用电线搬运、拉动电动工具或拔出其插头。
使电线远离热源、油、锐边或运动部件。
受损或缠绕的软线会增加电击危险。

- e) 当在户外使用电动工具时，使用适合户外使用的外接软线。
适合户外使用的软线将减少电击危险。
- f) 如果在潮湿环境下操作电动工具是不可避免的，应使用剩余电流动作保护器（RCD）。
使用RCD可减小电击危险。

3) 人身安全

- a) 保持警觉，当操作电动工具时关注所从事的操作并保持清醒。
当你感到疲倦，或在有药物、酒精或治疗反应时，不要操作电动工具。
在操作电动工具时瞬间的疏忽会导致严重人身伤害。
- b) 使用个人防护装置。始终佩戴护目镜。
安全装置，诸如适当条件下使用防尘面具、防滑安全鞋、安全帽、听力防护等装置能减少人身伤害。
- c) 防止意外起动。确保开关在连接电源和 / 或电池盒、拿起或搬运工具时处于关断位置。
手指放在已接通电源的开关上或开关处于接通时插入插头可能会导致危险。
- d) 在电动工具接通之前，拿掉所有调节钥匙或扳手。
遗留在电动工具旋转零件上的扳手或钥匙会导致人身伤害。
- e) 手不要伸展得太长。时刻注意立足点和身体平衡。
这样在意外情况下能很好地控制电动工具。
- f) 着装适当。不要穿宽松衣服或佩戴饰品。让衣服、手套和头发远离运动部件。
宽松衣服、佩饰或长发可能会卷入运动部件中。
- g) 如果提供了与排屑、集尘设备连接用的装置，要确保它们连接完好且使用得当。
使用这些装置可减少尘屑引起的危险。

4) 电动工具使用和注意事项

- a) 不要滥用电动工具，根据用途使用适当的电动工具。
选用适当设计的电动工具会使你工作更有效、更安全。
- b) 如果开关不能接通或关断工具电源，则不能使用该电动工具。
不能用开关来控制的电动工具是危险的且必须进行修理。
- c) 在进行任何调节、更换附件或贮存电动工具之前，必须从电源上拔掉插头和 / 或使电池盒与工具脱开。
这种防护性措施将减少工具意外起动的危险。
- d) 将闲置不用的电动工具贮存在儿童所及范围之外，并且不要让不熟悉电动工具或对这些说明不了解的人操作电动工具。
电动工具在未经培训的用户手中是危险的。
- e) 保养电动工具。检查运动件是否调整到位或卡住，检查零件破损情况和影响电动工具运行的其他状况。如有损坏，电动工具应在使用前修理好。
许多事故由维护不良的电动工具引发。
- f) 保持切削刀具锋利和清洁。
保养良好的有锋利切削刃的刀具不易卡住而且容易控制。

中文

- g) 按照使用说明书，考虑作业条件和进行的作业来使用电动工具、附件和工具的刀头等。

将电动工具用于那些与其用途不符的操作可能会导致危险。

5) 维修

- a) 将你的电动工具送交专业维修人员，使用同样的备件进行修理。
这样将确保所维修的电动工具的安全性。

注意！

不可让儿童和体弱人士靠近工作场所。

应将不使用的工具存放在儿童和体弱人士接触不到的地方。

电动锤钻安全警告

1. 请佩戴护耳罩。

暴露在噪声中会引起听力损伤。

2. 如果随工具提供辅助手柄，请使用。

操作失手会引起人身伤害。

3. 当在切削附件有可能碰到暗线或自身电线的场所进行操作时，只能通过绝缘握持面来握住电动工具。

切削附件碰到带电导线可能会使电动工具的外露金属零件带电并使操作者发生电击危险。

其它安全警告

1. 作业之后的钻头仍处在高热状态下，切不可摸触，以免灼伤。

2. 对墙壁、天花板和地板进行钻孔或钻碎作业时，应彻底查明里面是否敷设电缆或导管。

3. 使用锤钻时，应牢牢握住工具的操作柄和侧柄。否则，所产生的反作用力会将孔钻歪，甚至会造成危险。

4. 佩戴防尘口罩

不要吸入在钻凿操作过程中产生的有害粉尘。粉尘会危机到自身和旁观者的身体健康。

5. 安装工具

○ 为避免意外事故，请务必关闭开关并拔出电源插头。

○ 当使用尖钻、钻头工具时，请务必使用本公司原装配件。

○ 清洁钻头的柄部分。然后用润滑油或机油涂抹柄部分。

6. 当马达正在旋转时无法通过按转速选择开关更改旋转速度。若要更改速度，请首先将工具关闭。

7. RCD

推荐始终使用额定剩余电流为 30mA 以下的剩余电流动作保护器。

符号

警告！

如下所示的符号用于本机。使用前请务必理解其含意。



	为降低伤害风险，用户必须阅读使用说明书	n_0	空载转速
V	额定电压	--S/--S	运行时间 / 停机时间
A	电流	---/min	每分钟转动次数
W	瓦		二类工具

规格

型式	DH52MA
电压	220V ~
输入功率	1500W
空载转速	330/min
满载锤击率	2250/min
容量	钻头：52mm 取心钻具：160mm
重量	11.8kg

标准附件

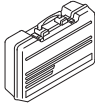
DH52MA 的附件请参见以下列表。

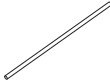
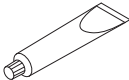
壳体（塑料模制品） （代码号 378308）		1
侧柄 （代码号 376577）		1
停止器 （代码号 971786）		1
电动锤润滑油 A （代码号 981840）		1

选购附件（分开销售）

1. 穿孔钻（旋钻+锤击）



● 钻头（五槽圆柄）

外径	总长	代号
16mm	340mm	313448
	540mm	313456
19mm	340mm	313449
	540mm	313457
22mm	320mm	313450
	520mm	313458
25mm	320mm	313451
	520mm	313459
28mm	370mm	313452
	570mm	313460
32mm	370mm	313453
	570mm	313461
38mm	370mm	313454
	570mm	313462
40mm	370mm	313455
	570mm	313463

2. 锚栓孔钻（旋钻+锤击）

SDS 加柄头的附加器



+



● 钻头（SDS 加柄）

● SDS 加柄头的附加器 （五槽圆柄）

代码号 313465

3. 大径孔钻（旋钻+锤击）



+

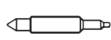

+



+



● 带导板

● 中间销

● 取心钻具

● 取心钻柄 （五槽圆柄）

代码号
985388
955169

代码号
955165

外径
50mm
105mm

代码号
313467

4. 钻孔用于钻金属和木材

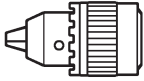

+

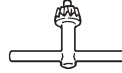

● 13mm 电钻夹盘
(13VLD-D)

● 夹盘附加器
(五槽圆柄)

● 夹盘扳手

代码号 321813

代码号 313468

代码号 930515

5. 用树脂锚栓进行螺栓放置作业。(旋钻+锤击)



+

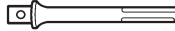

(市售的标准插座)

● 树脂锚栓附加器
(五槽圆柄)

插座安装侧的平面积	代码号
12.7mm	313469
19.0mm	313470

6. 破碎 (锤击)



● 尖凿

总长	代码号
280mm	313471
400mm	313472

7. 开槽和饰边 (锤击)

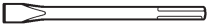

● 冷钻

总长	代码号
280mm	313473
400mm	313474

8. 切柏油 (锤击)



● 刀具

总长	宽度	代码号
400mm	50mm	313475

9. 挖掘



● 挖掘

代码号 313476

中文

10. 表面粗加工（锤击）

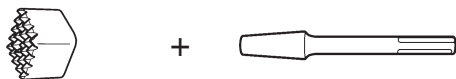

● 衬套工具

代码号 313477

● 柄

总长	代码号
220mm	313479

11. 夯实（锤击）



(1) 撞锤

代码号 313478

(2) 柄

总长	代码号
220 mm	313479

12. 洗涤剂（排屑用）

代码号 320859



13. 电动锤润滑油 A

500 g（罐装）代码号 980927

70 g（管装）代码号 308471

30 g（管装）代码号 981840

注：

如有规格变动，HiKOKI 概不负责。

用途

旋钻与锤钻 

○ 钻开锚栓孔

○ 对混凝土钻孔

单纯锤钻 

○ 混凝土破碎，凿平，挖掘，切屑（与选购件配合使用）

作业之前

1. 电源

确认所使用的电源与工具铭牌上标示的规格是否相符。

2. 电源开关

确认电源开关是否切断。若电源开关接通，则插头插入电源插座时电动工具将出其不意地立刻转动，从而招致严重事故。

3. 延伸线缆

若作业场所移到离开电源的地点，应使用容量足够、铠装合适的延伸线缆。延伸线缆要尽可能地短些。

4. 检查插座

如果插头插入插座后非常松动，就必须对插座进行修理。

联系持证电工，进行妥善修理。

如果使用这样的问题插座，可能会引起过热现象，进而造成严重危害。

5. 确认环境条件

确认工作场所条件合适，且符合规定的预防措施。

6. 安装侧柄

(1) 确认是否具备侧柄的所有部件。(图 1)



图 1

(2) 把夹箍放在夹箍连接区域，并将夹箍的两个孔放入把手螺栓的“T”形部位。(图 2、图 3)



图 2

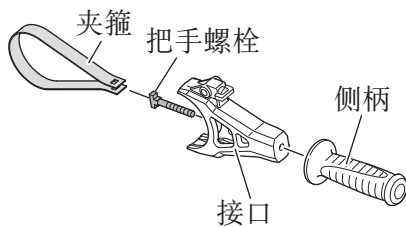

图 3

中文

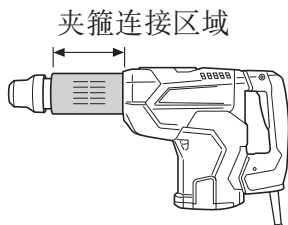
- (3) 用手拿着夹箍确保把手螺栓不会松动时，将手柄插进接口中。（图 4）
- (4) 将夹箍调整到适合任务的位置，转动侧柄，拧紧夹箍。一定要把夹箍拧紧。（图 5）

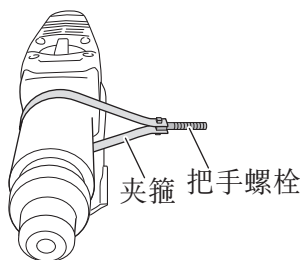

图 4



图 5

7. 如何安装工具

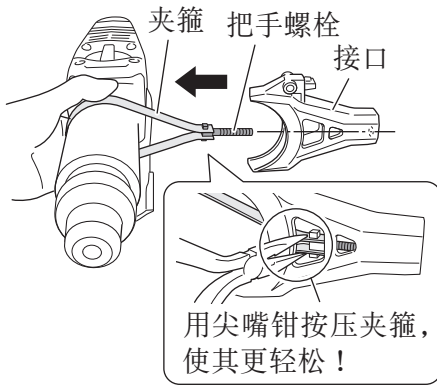
注意！

对于例如钻头和尖钻等工具，请仅使用HiKOKI正品部件。

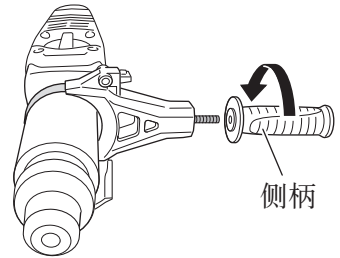
- (1) 先擦净，然后将附带的润滑油（装于绿管中）于工具柄上。
- (2) 如图 6 所示，要安装工具（五槽圆柄）时，将它插入孔内直至其抵达孔底。
如果继续轻轻转动工具，您可感觉到有钩处。在此位置，将夹持器推向箭头标记方向并将工具完全插入，直至其抵达尽头。
松开夹持器，使夹持器恢复原来的状态，并将工具固定在相应位置。
- (3) 拉动工具以确认它已被完全锁定。
- (4) 要卸下工具时，按箭头方向尽量拉动夹持器并拉出工具。



图 6

使用方法

1. 钻孔方法（图 7）

- (1) 把钻头放到钻孔位置，然后拉动开关触发器。
- (2) 锤钻只需稍按压，让夹具能自由排出即可，无需用力推压。

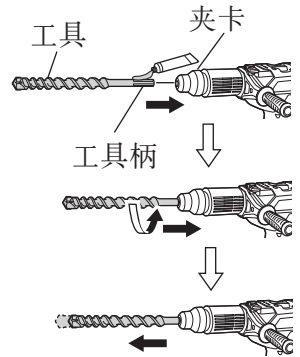

图 7

注意！

本机内装有滑动离合器，钻头碰到钢筋等硬物时，钻头会突然停止转动。这时，机身会因反冲力而转动。因此，进行作业时，必须牢牢握住侧柄和主柄。

2. 凿平和破碎（图 8）

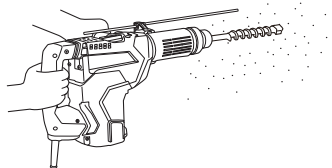
把工具放到凿平和破碎的作业位置上，利用手提电动锤钻自重进行作业。作业时，无需用力推压。

3. 在“旋钻+锤击”状态下钻孔时：

注意！

在马达转动时如果切换选择杆，工具会突然开始转动，从而导致意外事故发生。务请在马达完全停止转动后再切换选择杆。



图 8

(1) 切换至“旋钻+锤击”状态

- (a) 转动选择杆。
- (b) 如图 9 所示，将选择杆的 ▲ 对准曲柄盖座上的 IT。

注：

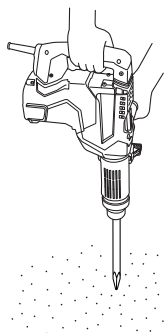
转动选择杆以查看它是否完全锁定并确认它不会转动。



图 9

4. 在“锤击”状态下凿平和凿孔：

注意！

- 如果在马达转动中切换选择杆，工具可能会突然开始转动而导致意外事故发生。务请在马达完全停止转动的状态下切换选择杆。
- 如果在“旋钻+锤击”的位置使用尖钻或冷凿，工具会开始转动而导致意外事故发生。务请在“锤击”的位置使用它们。

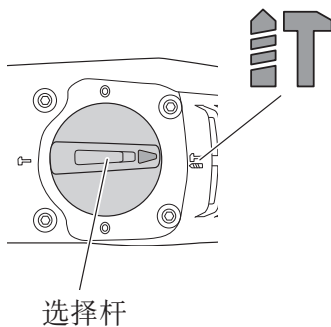
中文

(1) 切换至“锤击”

- (a) 转动选择杆。
- (b) 如图 10 所示，将选择杆的 ▲ 对准曲柄盖上的 T。

注：

转动选择杆以查看它是否被完全锁定并确认它不会转动。

(2) 当固定冷凿等的作业位置时

- (a) 转动选择杆。
如图 11 所示，将选择杆的 ▲ 对准选择杆座上的 ⊙。
- (b) 如图 12 所示，转动夹持器或工具并将工具固定在所需的作业方向。
- (c) 请根据上面 (1) 中所述的步骤，将选择杆切换至“锤击”的位置并固定工具的位置。

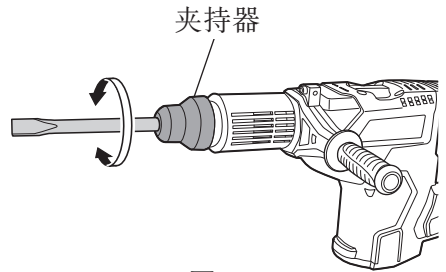
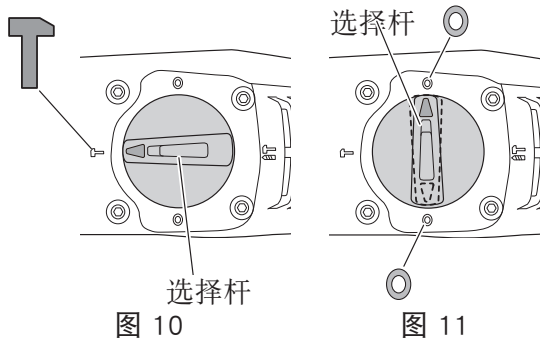

5. 安装挡块 (图 13)

- (1) 松开翼形螺栓，然后将挡块插入侧把手上的安装孔内。
- (2) 根据孔深调节挡块位置，然后牢牢拧紧翼形螺栓。

6. 加热 (图 14)

在寒冷地区，本装置的润滑油润滑系统可能需要加热。

使钻头前端触及混凝土表面，打开开关开始加热。注意，在听到钻击声后才使用本装置。

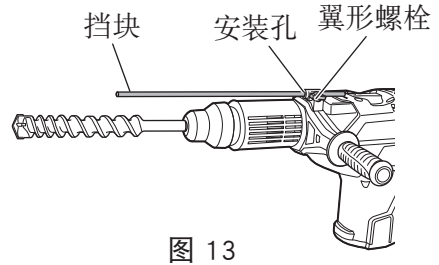

注意！

在进行加热作业时，请用双手稳稳地握住侧柄和钻体，并小心不要因钻头被卡住而使您的身体倾斜。

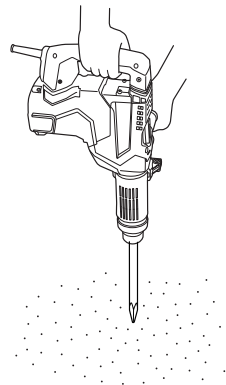

7. 如何使用钻头（锥柄）和锥柄转接器

- (1) 将带有锥柄的钻头安装在锥柄转接器中。
(图 15)
- (2) 开启电源并钻一个基础孔。
- (3) 使用洗涤剂清洁灰尘后，将柱塞安装在锚端，然后将带有柱塞的锚钉入锚端，并用手动锤将锚钉入。
- (4) 若要拆下带有锥柄的钻头，在锥柄转接器的缝隙中插入一个制销，将台座放置在电动锤钻下方并用手动锤敲击制销。(图 16)



图 15



图 16

使用锤钻夹盘和夹盘附加器

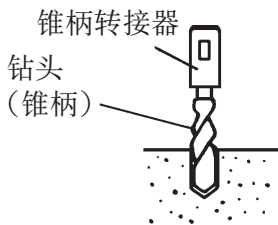
请注意，若安装锤钻夹盘和夹盘附加器等另售部件，本机可在“仅旋钻”状态下使用。请与在“旋钻+锤击”状态下定位的选择杆一起使用。

警告！

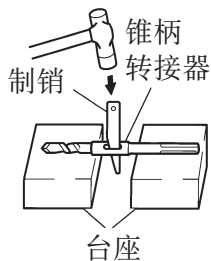
在操作中，请务必紧握把手和侧把手，以防您的身体摆动。

- (1) 切换至“旋钻+锤击”状态
有关切换至“旋钻+锤击”状态的操作，请按照第 11 页的〔3. 在“旋钻+锤击”状态下钻孔时〕中的相同步骤进行。
- (2) 将夹盘附加器安装在锤钻夹盘上(图 17)
 - (a) 将夹盘附加器安装在锤钻夹盘上。
 - (b) 夹盘附加器的五槽圆柄相当于钻头。因此，请按照第 10 页的〔7. 如何安装工具〕中的相同步骤进行安装和拆卸。



图 17

(3) 钻孔

- (a) 即使在机体上施加过大的压力，钻孔也不会达到您所期望的速度。若对机体用力过度或施加过大压力，反而会损坏钻头，导致工作效率下降并缩短本机的寿命。
- (b) 当钻孔快结束时钻头有时可能会折断。在钻孔快结束时，最好减小推力。

怎么样使用取心钻具

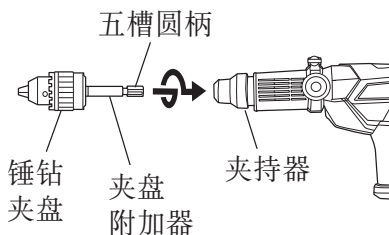
镗穿大孔时，可使用取心钻具（轻载用）进行作业。这时候，必需使用选购件的中间销和取心钻柄。

1. 安装

注意！

应先确认电源开关是否切断，插头有无从电源插座拆除。

- (1) 把取心钻具安装於取心钻柄（图 18）。
润滑取心钻柄的螺纹，可使拆解更加容易。
- (2) 把取心钻柄安装於电动锤钻（图 19）。
- (3) 把中间销插入於导板上直到受挡阻为止。

- (4) 把导板和取心钻具拼装起来，往右向或左向转动导板，直到朝下也不掉落（图 20）。

2. 怎么样进行钻孔（图 21）

- (1) 把插头插接於电源插座。
- (2) 中间销里装有弹簧。将其轻轻地笔直推入墙壁或地板。连接取心钻头尖端的全表面并开始操作。
- (3) 钻到大约 5 mm 深度，钻孔位置即可确定。这时候，可存从取心钻具拆下中间销和导板。
- (4) 过分用力不仅无助于作业，而且会损坏钻头的刀尖，缩短锤钻的寿命。

注意！

拆除中间销和导板时，应先切断开关，并从电源插座拆下插头。

3. 拆卸（图 22）

亦可从电动锤钻拆下取心钻柄，然后拿稳取心钻具，用手动锤强力锤击取心钻柄二至三次，让螺纹部松开，把取心钻具拆下。



图 18

图 19



图 20

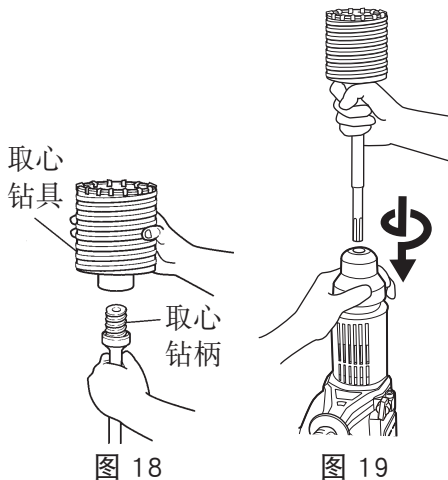

图 21



图 22

更换润滑油

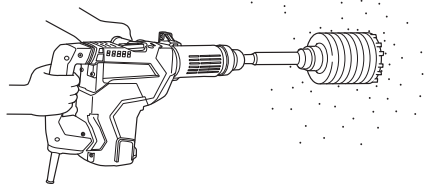
此电动锤钻具有完全气密结构，可阻隔灰尘并防止润滑油泄漏。

因此，此电动锤钻可以很长一段时间内都不需要使用润滑油。请如下所述更换润滑油。

润滑油更换时间

购买本产品后，每 6 个月需要更换一次润滑油。在更换润滑油时，请离您最近的授权服务中心进行更换。

维护和检查

警告！

在维护和检查期间，一定要“切断”电源，并将插座上的插头拔掉。

1. 检查钻头

使用迟钝的钻头，将使电动机工作失常，并降低作业效率。因此，若钻头发现显著的磨损，应立刻更换新件，或加以磨快。

2. 检查安装螺钉

要经常检查安装螺钉是否紧固妥善。若发现螺钉松了，应立即重新扭紧，否则会导致严重的事故。

3. 电动机的维护

电动机绕线是电动工具的“心脏部”应仔细检查有无损伤，是否被油液或水沾湿。

4. 检查炭刷：(图 23)

电动机采用的炭刷为消耗性部件。已磨损或接近“磨损极限”的炭刷将导致电机发生故障。装配自停式炭刷后，电机将自动停止。此时，请更换为与图示中相同炭刷号的新炭刷。

此外，经常保持炭刷清洁，确保炭刷在刷架内可顺畅滑动。



图 23

注意！

若电动锤钻的炭刷超出磨损极限，则将导致电机损坏。

○ 更换炭刷：

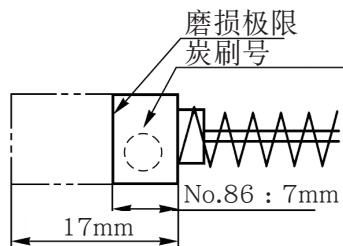
拧松两个固定螺钉并拆下后尾盖。拆下炭刷帽和炭刷。

更换炭刷后，拧紧炭刷帽和两个固定螺钉，安装后尾盖。

5. 更换电源线

如果需要更换电源线，则必须由此代理的生产厂商进行操作，以免发生危险。

注意！

在电动工具的操作和维护期间，必须遵守每个国家制定的安全条例和标准。

CONTENTS

GENERAL POWER TOOL SAFETY WARNINGS	16
ROTARY HAMMER SAFETY WARNINGS	18
ADDITIONAL SAFETY WARNINGS	19
SYMBOLS	19
SPECIFICATIONS	20
STANDARD ACCESSORIES	20
OPTIONAL ACCESSORIES (sold separately).....	20
APPLICATIONS.....	23
PRIOR TO OPERATION.....	24
HOW TO USE.....	26
USING DRILL CHUCK, CHUCK ADAPTER	28
HOW TO USE THE CORE BIT	29
GREASE REPLACEMENT	30
MAINTENANCE AND INSPECTION	30

GENERAL POWER TOOL SAFETY WARNINGS

WARNING

Read all safety warnings and all instructions.

Failure to follow the warnings and instructions may result in electric shock, fire and/or serious injury.

Save all warnings and instructions for future reference.

The term “power tool” in the warnings refers to your mains-operated (corded) power tool or battery-operated (cordless) power tool.

- 1) **Work area safety**
 - a) **Keep work area clean and well lit.**
Cluttered or dark areas invite accidents.
 - b) **Do not operate power tools in explosive atmospheres, such as in the presence of flammable liquids, gases or dust.**
Power tools create sparks which may ignite the dust or fumes.
 - c) **Keep children and bystanders away while operating a power tool.**
Distractions can cause you to lose control.
- 2) **Electrical safety**
 - a) **Power tool plugs must match the outlet.**
Never modify the plug in any way.
Do not use any adapter plugs with earthed (grounded) power tools.
Unmodified plugs and matching outlets will reduce risk of electric shock.
 - b) **Avoid body contact with earthed or grounded surfaces, such as pipes, radiators, ranges and refrigerators.**

There is an increased risk of electric shock if your body is earthed or grounded.

- c) **Do not expose power tools to rain or wet conditions.**
Water entering a power tool will increase the risk of electric shock.
- d) **Do not abuse the cord. Never use the cord for carrying, pulling or unplugging the power tool.**
Keep cord away from heat, oil, sharp edges or moving parts.
Damaged or entangled cords increase the risk of electric shock.
- e) **When operating a power tool outdoors, use an extension cord suitable for outdoor use.**
Use of a cord suitable for outdoor use reduces the risk of electric shock.
- f) **If operating a power tool in a damp location is unavoidable, use a residual current device (RCD) protected supply.**
Use of an RCD reduces the risk of electric shock.

3) Personal safety

- a) **Stay alert, watch what you are doing and use common sense when operating a power tool.**
Do not use a power tool while you are tired or under the influence of drugs, alcohol or medication.
A moment of inattention while operating power tools may result in serious personal injury.
- b) **Use personal protective equipment. Always wear eye protection.**
Protective equipment such as dust mask, non-skid safety shoes, hard hat, or hearing protection used for appropriate conditions will reduce personal injuries.
- c) **Prevent unintentional starting. Ensure the switch is in the off position before connecting to power source and/or battery pack, picking up or carrying the tool.**
Carrying power tools with your finger on the switch or energising power tools that have the switch on invites accidents.
- d) **Remove any adjusting key or wrench before turning the power tool on.**
A wrench or a key left attached to a rotating part of the power tool may result in personal injury.
- e) **Do not overreach. Keep proper footing and balance at all times.**
This enables better control of the power tool in unexpected situations.
- f) **Dress properly. Do not wear loose clothing or jewellery. Keep your hair, clothing and gloves away from moving parts.**
Loose clothes, jewellery or long hair can be caught in moving parts.
- g) **If devices are provided for the connection of dust extraction and collection facilities, ensure these are connected and properly used.**
Use of dust collection can reduce dust-related hazards.

4) Power tool use and care

- a) **Do not force the power tool. Use the correct power tool for your application.**
The correct power tool will do the job better and safer at the rate for which it was designed.

English

- b) **Do not use the power tool if the switch does not turn it on and off.**
Any power tool that cannot be controlled with the switch is dangerous and must be repaired.
- c) **Disconnect the plug from the power source and/or the battery pack from the power tool before making any adjustments, changing accessories, or storing power tools.**
Such preventive safety measures reduce the risk of starting the power tool accidentally.
- d) **Store idle power tools out of the reach of children and do not allow persons unfamiliar with the power tool or these instructions to operate the power tool.**
Power tools are dangerous in the hands of untrained users.
- e) **Maintain power tools. Check for misalignment or binding of moving parts, breakage of parts and any other condition that may affect the power tool's operation.**
If damaged, have the power tool repaired before use.
Many accidents are caused by poorly maintained power tools.
- f) **Keep cutting tools sharp and clean.**
Properly maintained cutting tools with sharp cutting edges are less likely to bind and are easier to control.
- g) **Use the power tool, accessories and tool bits etc. in accordance with these instructions, taking into account the working conditions and the work to be performed.**
Use of the power tool for operations different from those intended could result in a hazardous situation.

5) Service

- a) **Have your power tool serviced by a qualified repair person using only identical replacement parts.**
This will ensure that the safety of the power tool is maintained.

CAUTION

Keep children and infirm persons away.

When not in use, tools should be stored out of reach of children and infirm persons.

ROTARY HAMMER SAFETY WARNINGS

- 1. **Wear ear protectors.**
Exposure to noise can cause hearing loss.
- 2. **Use auxiliary handle(s), if supplied with the tool.**
Loss of control can cause personal injury.
- 3. **Hold power tool by insulated gripping surfaces, when performing an operation where the cutting accessory may contact hidden wiring or its own cord.**
Cutting accessory contacting a "live" wire may make exposed metal parts of the power tool "live" and could give the operator an electric shock.



ADDITIONAL SAFETY WARNINGS

1. Do not touch the bit during or immediately after operation. The bit becomes very hot during operation and could cause serious burns.
2. Before starting to break, chip or drill into a wall, floor or ceiling, thoroughly confirm that such items as electric cables or conduits are not buried inside.
3. Always hold the body handle and side handle of the power tool firmly. Otherwise the counterforce produced may result in inaccurate and even dangerous operation.
4. Wear a dust mask.
Do not inhale the harmful dusts generated in drilling or chiseling operation. The dust can endanger the health of yourself and bystanders.
5. Mounting the tool
 - To prevent accidents, make sure to turn the switch off and disconnect the plug from the receptacle.
 - When using tools such as bull points, drill bits, etc., make sure to use the genuine parts designated by our company.
 - Clean the shank portion of the drill bit. Then smear the shank portion with the grease or machine oil.
6. The rotation speed cannot be changed by pressing the rotation speed selector switch while the motor is rotating. To change speeds, switch off the tool first.
7. RCD
The use of a residual current device with a rated residual current of 30 mA or less at all times is recommended.

SYMBOLS

WARNING

The following show symbols used for the machine. Be sure that you understand their meaning before use.



	To reduce the risk of injury, user must read instruction manual.	n_0	No-load speed
V	Rated voltage	--S/--S	Running Time / Down Time
A	Current	---/min	revolutions per minute
W	Watt		Class II tool

SPECIFICATIONS

Model	DH52MA
Voltage	220 V ~
Power input	1500 W
No-load speed	330 /min
Full-load impact rate	2250 /min
Capacity	Drill bit: 52 mm Core bit: 160 mm
Weight	11.8 kg

STANDARD ACCESSORIES

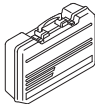
See the list below to check the accessories for DH52MA.

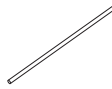
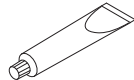
Case (Molded plastic) (Code No. 378308)		1
Side Handle (Code No. 376577)		1
Stopper (Code No. 971786)		1
Hammer Grease A (Code No. 981840)		1

OPTIONAL ACCESSORIES (sold separately)

1. Through-hole drilling (Rotation + Hammering)



● Drill bit (SDS max shank)

External dia.	Overall length	Code No.
16 mm	340 mm	313448
	540 mm	313456
19 mm	340 mm	313449
	540 mm	313457
22 mm	320 mm	313450
	520 mm	313458
25 mm	320 mm	313451
	520 mm	313459
28 mm	370 mm	313452
	570 mm	313460
32 mm	370 mm	313453
	570 mm	313461
38 mm	370 mm	313454
	570 mm	313462
40 mm	370 mm	313455
	570 mm	313463

2. Anchor hole drilling (Rotation + Hammering)

Adapter for SDS-plus shank bit



● Drill bit (SDS-plus shank)

● Adapter for SDS-plus shank bit (SDS max shank)

Code No. 313465

3. Large dia. hole boring (Rotation + Hammering)



● Guide plate

● Center pin

● Core bit

● Core bit shank (SDS max shank)

Code No.
985388
955169

Code No.
955165

External dia.
50 mm
105 mm

Code No.
313467

English

4. Drilling holes..... For drilling metal and wooden materials

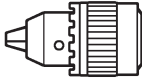

+

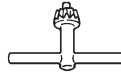
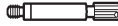

● 13 mm drill chuck
(13VLD-D)

● Chuck adapter
(SDS max shank)

● Chuck wrench

Code No. 321813

Code No. 313468

Code No. 930515

5. Bolt plaching operation with Chemical Anchor (Rotation + Hammering)



+

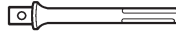

(Standard socket on
the market)

● Chemical Anchor Adaptor
(SDS max shank)

Square dimensions of the side of the socket installation	Code No.
12.7 mm	313469
19.0 mm	313470

6. Crushing (Hammering)



● Bull point

Overall length	Code No.
280 mm	313471
400 mm	313472

7. Groove digging and edging (Hammering)

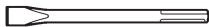

● Cold chisel

Overall length	Code No.
280 mm	313473
400 mm	313474

8. Asphalt cutting (Hammering)



● Cutter

Overall length	Width	Code No.
400 mm	50 mm	313475

9. Digging

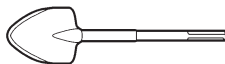

● Scoop

Code No. 313476

10. Surface Roughing (Hammering)



+

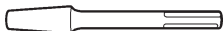

● Bushing Tool

Code No. 313477

● Shank

Overall length	Code No.
220 mm	313479

11. Tamping (Hammering)



+

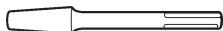

(1) Rammer

Code No. 313478

(2) Shank

Overall length	Code No.
220 mm	313479

12. Syringe (for chip removal)

Code No. 320859



13. Hammer grease A

500 g (in a can) Code No. 980927

70 g (in a tube) Code No. 308471

30 g (in a tube) Code No. 981840

NOTE

Specifications are subject to change without any obligation on the part of the HiKOKI.

APPLICATIONSRotation and hammering function 

- Drilling anchor holes
- Drilling holes in concrete

Hammering only function 

- Crushing concrete, chipping, digging, and squaring (by applying optional accessories)

PRIOR TO OPERATION

1. Power source
Ensure that the power source to be utilized conforms to the power requirements specified on the product nameplate.
2. Power switch
Ensure that the power switch is in the OFF position. If the plug is connected to a receptacle while the power switch is in the ON position, the power tool will start operating immediately, which could cause a serious accident.
3. Extension cord
When the work area is removed from the power source, use an extension cord of sufficient thickness and rated capacity. The extension cord should be kept as short as practicable.
4. Check the receptacle
If the receptacle only loosely accepts the plug, the receptacle must be repaired. Contact a licensed electrician to make appropriate repairs. If such a faulty receptacle is used, it may cause overheating, resulting in a serious hazard.
5. Confirming condition of the environment
Confirm that the work site is placed under appropriate conditions conforming to prescribed precautions.

6. Installing the Side Handle

- (1) Check that you have all the parts of the Side Handle. (**Fig. 1**)

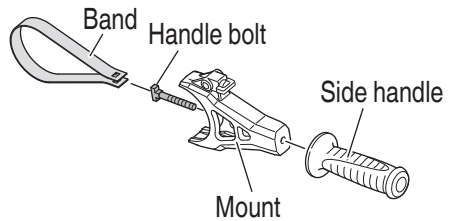

Fig. 1

- (2) Place the band over the band attachment area and fit the band's two holes onto the "T" portion of the handle bolt. (**Fig. 2, 3**)

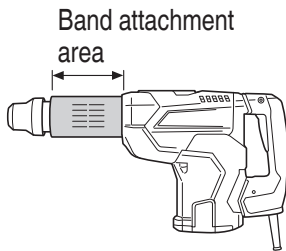

Fig. 2

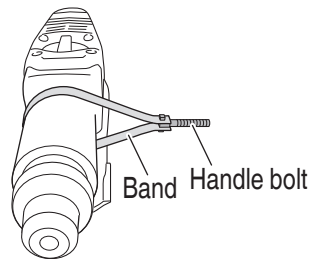

Fig. 3

- (3) As you hold the band to make sure the handle bolt won't come loose, insert the handle bolt into the mount. (**Fig. 4**)
- (4) Adjusting the band to a position that is suitable for the task, turn the side handle to fasten the band. Make sure that the band is securely fastened. (**Fig. 5**)

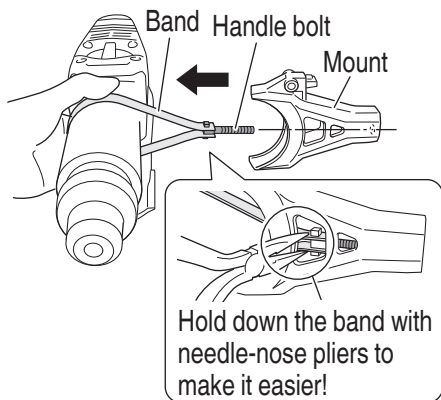

Fig. 4

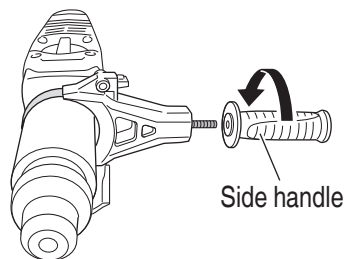

Fig. 5

7. How to install tool

CAUTION

For tools such as a drill bit and a bull point, use only HiKOKI genuine parts.

- (1) Clean, then smear the tool shank with the grease provided in the green tube.
- (2) To attach the tool (SDS max shank), insert it into the hole until it contacts the innermost end of the hole as illustrated in **Fig. 6**.

If you continue to turn the tool with slight pressure, you can feel a spot where there is a hitch. At that spot, pull the grip to the direction of an arrow mark and insert the tool all the way until it hits the innermost end. Releasing the grip reverts the grip and secures the tool in place.

- (3) Pull the tool to make sure it is locked completely.
- (4) To remove the tool, fully pull the grip in the direction of the arrow and pull out the tool.

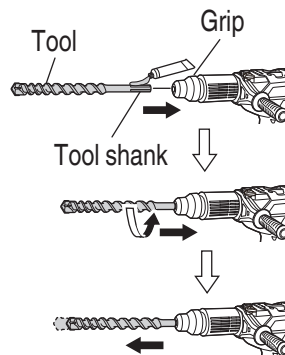

Fig. 6

HOW TO USE

1. How to drill holes (**Fig. 7**)
 - (1) Pull the switch trigger after applying the drill bit tip to the drilling position.
 - (2) It is unnecessary to forcibly press the rotary hammer main body. It is sufficient to slightly press the rotary hammer to an extent that chips are freely discharged.

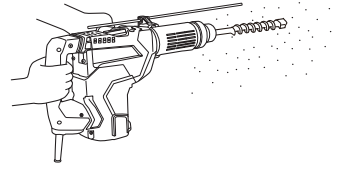

Fig. 7

CAUTION

Although this machine is equipped with a slip clutch, if the drill bit becomes bound in concrete or other material, the resultant stoppage of the drill bit could cause the machine body to turn in reaction. Ensure that the main handle and side handle are gripped firmly during operation.

2. How to chisel or crush (**Fig. 8**)

By applying the tool tip to the chiseling or demolishing position, operate the rotary hammer by utilizing its empty weight. Forcible pressing or thrusting is unnecessary.
3. When drilling at “rotation + hammering”:

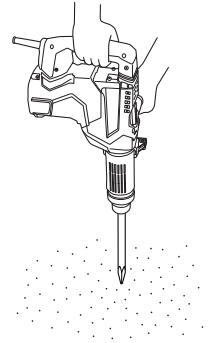

Fig. 8

CAUTION

If you switch the selector lever during motor rotation, the tool can start to rotate abruptly, resulting in unexpected accidents. Be sure to switch the selector lever when the motor is at a complete stop.

- (1) Switching to “rotation + hammering”
 - (a) Turn the selector lever.
 - (b) Align ▲ of the selector lever and ■ of the crank cover as illustrated in **Fig. 9**.

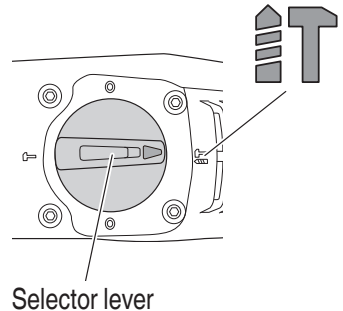

Fig. 9

NOTE

Turn the selector lever to check if it is completely locked and make sure that it does not turn.

4. When chipping and chiseling at “hammering”:

CAUTION

- If the selector lever is switched during motor rotation, the tool can start to rotate abruptly, resulting in unexpected accidents. Make sure to switch the selector lever when the motor is at a complete stop.
- If the bull point or cold chisel is used at the position of “rotation + hammering”, the tool can start to rotate, resulting in unexpected accidents. Make sure that they are used at the position of “hammering”.

- (1) Switching to “hammering”
 - (a) Turn the selector lever.
 - (b) Align ▲ of the selector lever and T of the crank cover as illustrated in Fig. 10.

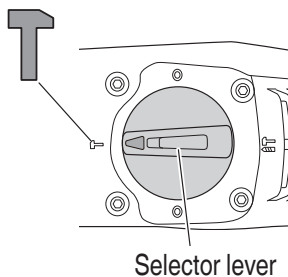

Fig. 10

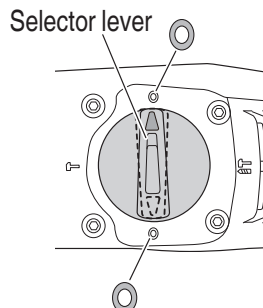

Fig. 11

NOTE

Turn the selector lever to check if it is completely locked and make sure that it does not turn.

- (2) When fixing working positions of tools such as cold chisel, etc.,
 - (a) Turn the selector lever. Align ▲ of the selector lever and ○ of the lever holder as illustrated in Fig. 11.
 - (b) Turn the grip or the tool as illustrated in Fig. 12 and fix the tool to the desired working direction.
 - (c) Switch the selector lever to “hammering” according to the procedures mentioned in the above item (1) and secure the position of the tool.

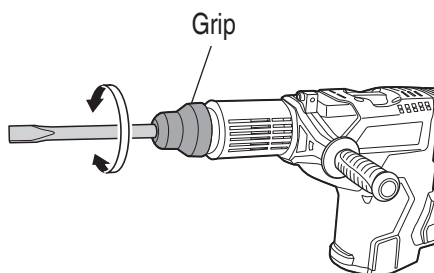

Fig. 12

5. Install the stopper (Fig. 13)
 - (1) Loosen the wing bolt, and insert the stopper into the mounting hole on the side handle.
 - (2) Adjust the stopper position according to the depth of the hole and tighten the wing bolt securely.
6. Warming up (Fig. 14)

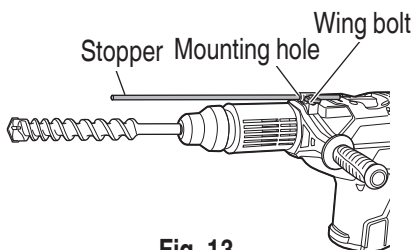

Fig. 13

The grease lubrication system in this unit may require warming up in cold regions. Position the end of the bit so makes contact with the concrete, turn on the switch and perform the warming up operation. Make sure that a hitting sound is produced and then use the unit.

CAUTION

When the warming up operation is performed, hold the side handle and the main body securely with both hands to maintain a secure grip and be careful not to twist your body by the jammed drill bit.

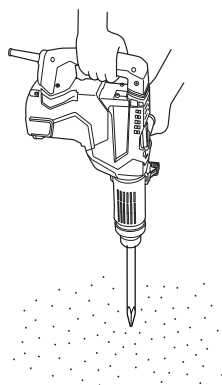

Fig. 14

English

7. How to use the drill bit (taper shank) and the taper shank adaptor.
 - (1) Install drill bit with taper shank in the taper shank adaptor. (**Fig. 15**)
 - (2) Turn the power on and drill a base hole.
 - (3) After cleaning out dust with a syringe, attach the plug to the anchor tip and drive in the anchor with plug to the anchor tip and drive in the anchor with a manual hammer.
 - (4) To remove the drill bit with taper shank, insert a cotter into the slot of the taper shank adaptor, place supports under the Rotary Hammer and tap the cotter with a manual hammer. (**Fig. 16**)

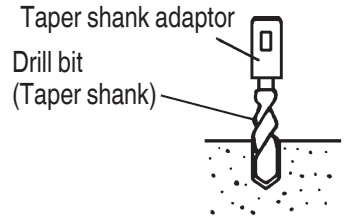

Fig. 15

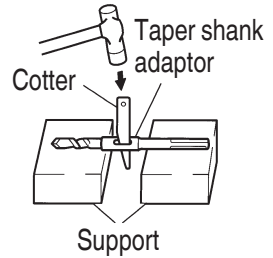

Fig. 16

USING DRILL CHUCK, CHUCK ADAPTER

Note that this machine can be used at “rotation only” if separately sold parts such as drill chuck and chuck adapter are attached. Use it with the selector lever positioned at “rotation + hammering”.

WARNING

During operation, be sure to grip the handle and the side handle firmly to prevent your body from swaying.

- (1) Switching to “rotation + hammering”
For switching to “rotation + hammering”, follow the same procedures mentioned in [3. When drilling at “rotation + hammering”] in page 26.
- (2) Attaching chuck adapter to drill chuck (**Fig. 17**)
 - (a) Attach the chuck adapter to the drill chuck.
 - (b) The SDS max shank of the chuck adapter is equivalent to the drill bit. Therefore, follow the same procedure as [7. How to install tool] in page 25 for attaching and detaching.
- (3) Drilling
 - (a) Even if you apply more-than-required pressure to the machine body, drilling can never be performed as quickly as you expect. Applying more force or pressure to the machine body than what is needed, on the contrary, damages the drill tip, resulting in the declined working efficiency and shortened life of this machine.
 - (b) A drill can snap sometimes when drilling is almost finished. It is important to relax your thrusting pressure when drilling is nearing the end.

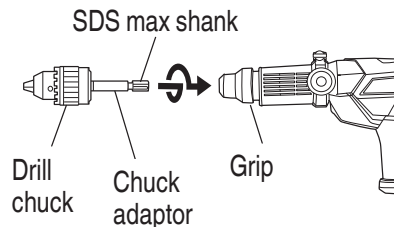

Fig. 17

HOW TO USE THE CORE BIT

When boring penetrating large holes use the core bit. At that time use with the center pin and the core bit shank provided as optional accessories.

1. Mounting

CAUTION

Be sure to turn power OFF and disconnect the plug from the receptacle.

- (1) Mount the core bit to the core bit shank (Fig. 18). Lubricate the thread of the core bit shank to facilitate disassembly.
- (2) Mount the core bit shank to the rotary hammer (Fig. 19).
- (3) Insert the center pin into the guide plate until it stops.
- (4) Engage the guide plate with the core bit, and turn the guide plate to the left or the right so that it does not fall even if it faces downward (Fig. 20).

2. How to bore (Fig. 21)

- (1) Connect the plug to the receptacle.
- (2) A spring is installed in the center pin. Push it lightly to the wall or the floor straight. Connect all over the surface of the core bit tip and start operating.
- (3) When boring about 5 mm in depth the position of the hole will be established. Bore after that removing the center pin and the guide plate from core bit.
- (4) Application of excessive force will not only expedite the work, but will deteriorate the tip edge of the drill bit, resulting in reduced service life of the rotary hammer.

CAUTION

When removing the center pin and the guide plate, turn OFF the switch and disconnect the plug from the receptacle.

3. Dismounting (Fig. 22)

Remove the core bit shank from the rotary hammer and strike the head of the core bit shank strongly two or three times with a manual hammer holding the core bit, then the thread becomes loose and the core bit can be removed.

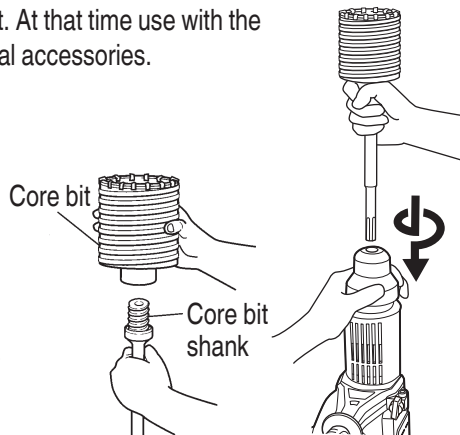

Fig. 18

Fig. 19

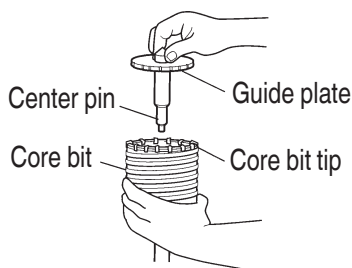

Fig. 20

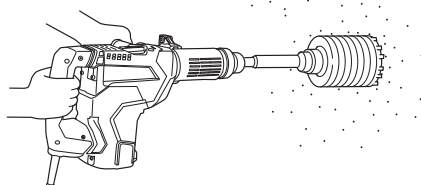

Fig. 21



Fig. 22

GREASE REPLACEMENT

This Rotary Hammer is of full air-tight construction to protect against dust and to prevent lubricant leakage.

Therefore, this Rotary Hammer can be used without lubrication for long periods. Replace the grease as described below.

Grease Replacement Period

After purchase, replace grease after every 6 months of usage. Ask for grease replacement at the nearest authorized Service Center.

MAINTENANCE AND INSPECTION

WARNING

Be sure to switch power OFF and disconnect the plug from the receptacle during maintenance and inspection.

1. Inspecting the drill bits
Since use of a dull tool will cause motor malfunctioning and degraded efficiency, replace the drill bit with new ones or sharpen them without delay when abrasion is noted.
2. Inspecting the mounting screws
Regularly inspect all mounting screws and ensure that they are properly tightened. Should any of the screws be loose, retighten them immediately. Failure to do so could result in serious hazard.
3. Maintenance of the motor
The motor unit winding is the very "heart" of the power tool. Exercise due care to ensure the winding does not become damaged and/or wet with oil or water.
4. Inspecting the carbon brushes: **(Fig. 23)**
The motor employs carbon brushes which are consumable parts. When they become worn to or near "wear limit", it could result in motor trouble. When an auto-stop carbon brush is equipped, the motor will stop automatically. At that time, replace both carbon brushes with new ones which have the same carbon brush Nos. shown in the figure. In addition, always keep carbon brushes clean and ensure that they slide freely within the brush holders.

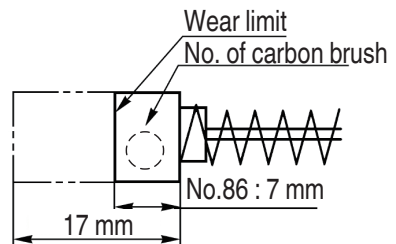

Fig. 23

CAUTION

Using this Rotary Hammer with a carbon brush which is worn in excess of the wear limit will damage the motor.

- Replacing carbon brushes:
Loosen the two set screws and remove the tail cover. Remove the brush caps and carbon brushes.
After replacing the carbon brushes, tighten the brush caps securely and to install the tail cover with securely tightening two set screws.
- 5. Replacing supply cord
If the replacement of the supply cord is necessary, this has to be done by the manufacturer of this agent in order to avoid a safety hazard.

CAUTION

In the operation and maintenance of power tools, the safety regulations and standards prescribed in each country must be observed.

服务中心
高壹工机商业(上海)有限公司
上海市闵行区浦江工业园区三鲁路3585号7幢3楼

制造商
高壹工机(马来西亚)有限公司
马来西亚柔佛州士乃第二工业区

Koki Holdings Co., Ltd.

202
编号: C99743921 M
发行日期: 2022年 2月
中国印刷