

HIKOKI

中文
English

充电式冲击扳手 Cordless Impact Wrench

WR 18DF

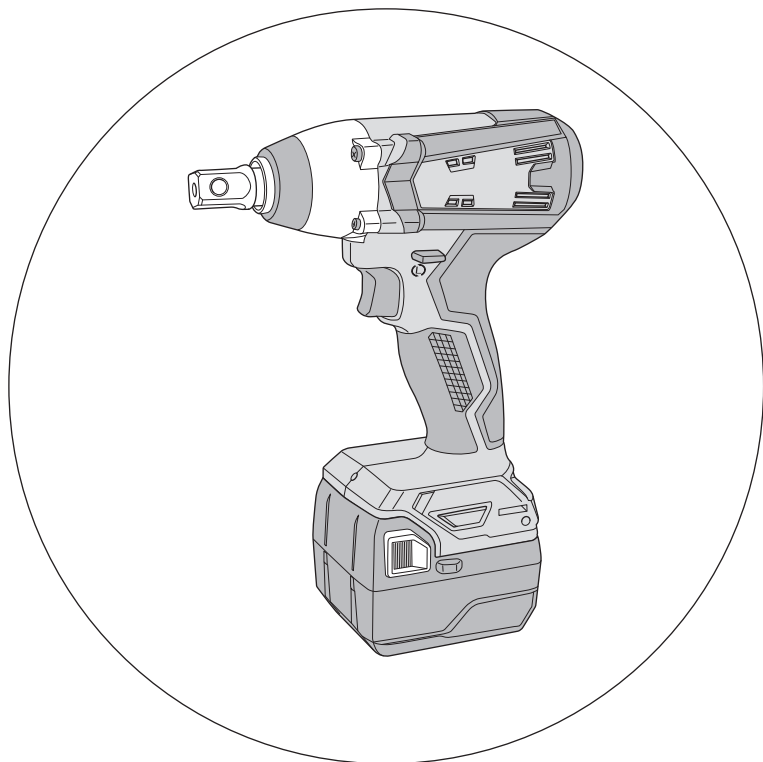

保留备用
Keep for future reference



使用说明书 Handling instructions

目次

电动工具通用安全警告.....	2	用途.....	10
充电式冲击扳手安全警告.....	4	电池的拆卸 / 安装法.....	10
锂离子电池使用注意事项.....	6	充电.....	11
锂离子电池运输.....	7	作业之前.....	13
符号.....	8	使用方法.....	14
零件名称.....	8	操作上的注意事项.....	15
规格.....	9	维护和检查.....	17
标准附件.....	10	选择附件.....	18

电动工具通用安全警告

⚠ 警告！

阅读所有警告和所有说明。

不遵照以下警告和说明会导致电击、着火和 / 或严重伤害。

保存所有警告和说明书以备查阅。

在所有下列的警告中术语“电动工具”指市电驱动(有线)电动工具或电池驱动(无线)电动工具。

1) 工作场地的安全

- a) 保持工作场地清洁和明亮。
混乱和黑暗的场地会引发事故。
- b) 不要在易爆环境，如有易燃液体、气体或粉尘的环境下操作电动工具。
电动工具产生的火花会点燃粉尘或气体。
- c) 让儿童和旁观者离开后操作电动工具。
注意力不集中会使操作者失去对工具的控制。

2) 电气安全

- a) 电动工具插头必须与插座相配。绝不能以任何方式改装插头。
需接地的电动工具不能使用任何转换插头。
未经改装的插头和相配的插座将减少电击危险。
- b) 避免人体接触接地表面，如管道、散热片和冰箱。
如果你身体接地会增加电击危险。
- c) 不得将电动工具暴露在雨中或潮湿环境中。
水进入电动工具将增加电击危险。
- d) 不得滥用电线。绝不能用电线搬运、拉动电动工具或拔出其插头。
使电线远离热源、油、锐边或运动部件。
受损或缠绕的软线会增加电击危险。

- e) 当在户外使用电动工具时，使用适合户外使用的外接软线。
适合户外使用的软线将减少电击危险。
- f) 如果在潮湿环境下操作电动工具是不可避免的，应使用剩余电流动作保护器（RCD）。
使用RCD可减小电击危险。

3) 人身安全

- a) 保持警觉，当操作电动工具时关注所从事的操作并保持清醒。
当你感到疲倦，或在有药物、酒精或治疗反应时，不要操作电动工具。
在操作电动工具时瞬间的疏忽会导致严重人身伤害。
- b) 使用个人防护装置。始终佩戴护目镜。
安全装置，诸如适当条件下使用防尘面具、防滑安全鞋、安全帽、听力防护等装置能减少人身伤害。
- c) 防止意外起动。确保开关在连接电源和 / 或电池盒、拿起或搬运工具时处于关断位置。
手指放在已接通电源的开关上或开关处于接通时插入插头可能会导致危险。
- d) 在电动工具接通之前，拿掉所有调节钥匙或扳手。
遗留在电动工具旋转零件上的扳手或钥匙会导致人身伤害。
- e) 手不要伸展得太长。时刻注意立足点和身体平衡。
这样在意外情况下能很好地控制电动工具。
- f) 着装适当。不要穿宽松衣服或佩戴饰品。让衣服、手套和头发远离运动部件。
宽松衣服、佩饰或长发可能会卷入运动部件中。
- g) 如果提供了与排屑、集尘设备连接用的装置，要确保它们连接完好且使用得当。
使用这些装置可减少尘屑引起的危险。

4) 电动工具使用和注意事项

- a) 不要滥用电动工具，根据用途使用适当的电动工具。
选用适当设计的电动工具会使你工作更有效、更安全。
- b) 如果开关不能接通或关断工具电源，则不能使用该电动工具。
不能用开关来控制的电动工具是危险的且必须进行修理。
- c) 在进行任何调节、更换附件或贮存电动工具之前，必须从电源上拔掉插头和 / 或使电池盒与工具脱开。
这种防护性措施将减少工具意外起动的危险。
- d) 将闲置不用的电动工具贮存在儿童所及范围之外，并且不要让不熟悉电动工具或对这些说明不了解的人操作电动工具。
电动工具在未经培训的用户手中是危险的。
- e) 保养电动工具。检查运动件是否调整到位或卡住，检查零件破损情况和影响电动工具运行的其他状况。如有损坏，电动工具应在使用前修理好。
许多事故由维护不良的电动工具引发。

- f) 保持切削刀具锋利和清洁。

保养良好的有锋利切削刃的刀具不易卡住而且容易控制。

- g) 按照使用说明书，考虑作业条件和进行的作业来使用电动工具、附件和工具的刀头等。

将电动工具用于那些与其用途不符的操作可能会导致危险。

5) 电池式工具使用和注意事项

- a) 只用制造商规定的充电器充电。

将适用于某种电池盒的充电器用到其他电池盒时会发生着火危险。

- b) 只使用配有特制电池盒的电动工具。

使用其他电池盒会发生损坏和着火危险。

- c) 当电池盒不用时，将它远离其他金属物体，例如回形针、硬币、钥匙、钉子、螺钉或其他小金属物体，以防一端与另一端连接。

电池端部短路会引起燃烧或火灾。

- d) 在滥用条件下，液体会从电池中溅出；避免接触。如果无意间碰到了，用水冲洗。如果液体碰到了眼睛，还要寻求医疗帮助。

从电池中溅出的液体会发生腐蚀或燃烧。

6) 维修

- a) 将你的电动工具送交专业维修人员，使用同样的备件进行修理。

这样将确保所维修的电动工具的安全性。

注意！

不可让儿童和体弱人士靠近工作场所。

应将不使用的工具存放在儿童和体弱人士接触不到的地方。

充电式冲击扳手安全警告

1. 在执行紧固件可能会接触到暗线的操作时，通过绝缘的抓紧表面拿住电动工具。接触“带电”电线的紧固件会使电动工具的裸露金属部件“带电”，并可能使操作员遭到电击。
2. 这是用于拧紧和旋松螺栓和螺母的手提式工具。请仅用于这些操作。
3. 长时间使用时请戴上耳塞。
4. 单手操作非常危险，操作时请用双手牢牢握住本扳手。
5. 检查套筒是否破裂或损坏，破裂或损坏的套筒很危险。使用前请检查套筒。
6. 用套筒销和套筒环固定套筒。

如果固定套筒的套筒销或套筒环损坏，套筒就可能会从冲击扳手上脱落，这是很危险的。请勿使用变形、磨损、破裂等损坏的套筒销或套筒环。务必将套筒销和套筒环装在正确的位置。

7. 检查拧紧扭矩。
拧紧螺丝所需的适当转矩取决于螺栓的材料、尺寸和等级等。
由此冲击扳手产生的拧紧扭矩还取决于螺栓的材料、尺寸、装上套筒的本冲击扳手的使用时间等。
电池刚充电和将耗尽时的转矩也有些许不同。请用转矩扳手检查是否用适当的转矩拧紧了螺栓。
8. 切换旋转方向前请停下本冲击扳手。切换旋转方向前请放开开关，并等待冲击扳手停下。
9. 切勿触摸转动部分。
请勿让转动着的套筒部分接近手或身体的其它部分，否则会被割伤或被夹入套筒。长时间持续使用套筒后请注意不要触摸套筒，因为套筒会变得很热，从而可能会被烫伤。
10. 使用万向接头时切勿在没有负载的情况下转动冲击扳手。
如果在没有连接负载的情况下转动套筒，万向接头会使套筒转动失控。从而可能会使您受伤，或者套筒的转动可能会强烈震动冲击扳手使其掉下。
11. 务请在 0°C — 40°C 的温度下进行充电。温度低于 0°C 将会导致充电过度，极其危险。
电池不能在高于 40°C 的温度下充电。
最适合于充电的温度是 20 — 25°C 。
12. 不要连续使用充电器。
一次充电完毕后，在 15 分钟内不要再次使用该充电器对电池充电。
13. 勿让杂质进入充电式电池连结口内。
14. 切勿拆卸充电式电池与充电器。
15. 切勿使充电式电池短路。使电池短路将会造成很大的电流和过热，从而烧坏电池。
16. 请勿将电池丢入火中。
电池受热将会爆炸。
17. 请勿将异物插入充电器的通风口。
若将金属异物或易燃物插入通风口的话，将会引起触电事故或使充电器受损。
18. 充电后电池寿命太短不够使用时，请尽快将电池送往经销店。请勿将用过的电池乱丢。
19. 请勿使用工具或电池端子（电池安装部位）明显变形的产品。
否则，安装电池后可能会短路，造成冒烟或起火。
20. 请清除工具端子（电池安装部位）上的削屑和灰尘。
 - 使用前请确保电池上没有堆积削屑和灰尘。
 - 在使用过程中，请尽量避免工具上的削屑或灰尘掉落在电池上。
 - 暂时不使用工具时或使用后，应将工具存放在不会掉落削屑或灰尘的地方。否则可能短路，造成冒烟或起火。

锂离子电池使用注意事项

为延长使用期限，锂离子电池备配停止输出的保护功能。

若是在使用本产品时发生下列 1 至 3 的情况，即使按下开关，马达也可能停止。这并非故障，而是启动保护功能的结果。

1. 在残留的电池电力即将耗尽时，马达会停止。
在这种情况下，请立即予以充电。
 2. 若工具超过负荷，马达亦可能停止。在这种情况下，请松开工具的开关，试着消除超过负荷的原因。之后您就可以再度使用。
 3. 若电池在过载工作情况下过热，电池电力可能会中止。
在这种情况下，请停止使用电池，让电池冷却。之后您就可以再度使用。
- 此外，请留心下列的警告及注意事项。

警告！

为防止发生电池漏电、发热、冒烟、爆炸及提前点燃，请确保留意下列事项。

1. 确保电池上没有堆积削屑及灰尘。
 - 在工作时确定削屑及灰尘没有掉落在电池上。
 - 确定所有工作时掉落在电动工具上的削屑和灰尘没有堆积在电池上。
 - 请勿将未使用的电池存放在曝露于削屑和灰尘的位置。
 - 在存放电池之前，请清除任何可能附着在上面的削屑和灰尘，并请切勿将它与金属零件（螺丝、钉子等）存放在一起。
2. 请勿以钉子等利器刺穿电池、以铁锤敲打、踩踏、丢掷电池，或将其剧烈撞击。
3. 切勿使用明显损坏或变形的电池。
4. 使用电池时请勿颠倒电极。
5. 请勿直接连接电源插座或汽车点烟器孔座。
6. 请依规定方式使用电池，切勿移作他用。
7. 如果已过了再充电时间，电池仍无法完成充电，请立即停止继续再充电。
8. 请勿将电池放置于高温或高压处，例如微波炉、烘干机或高压容器内。
9. 在发觉有渗漏或异味时，请勿接近远离火源。
10. 请勿在会产生强烈静电的地方使用。
11. 如有电池渗漏、异味、发热、褪色或变形，或在使用、充电或存放时出现任何异常，请立即将它从装备或电池充电器拆下，并停止使用。
12. 请勿浸泡电池或让任何液体流入电池内部。导电液体进入（如水），可能造成电池损坏，甚至可导致火灾或爆炸。将电池存放在阴凉、干燥的地方，远离易燃物品。必须避免将电池置于腐蚀性气体环境中。

注意！

1. 若电池渗漏出的液体进入您的眼睛，请勿搓揉眼睛，并以自来水等干净清水充分冲洗，立刻送医。
若不加以处理，液体可能会导致眼睛不适。
2. 若液体渗漏至您的皮肤或衣物，请立即以自来水等清水冲洗。
上述情况可能会使皮肤受到刺激。
3. 若初次使用电池时发现生锈、异味、过热、褪色、变形及 / 或其它异常情况时，请勿使用并将该电池退还给供货商或厂商。

警告！

如果导电异物进入锂离子电池端子之间，可能发生短路，并造成火灾危险。存放电池时，请遵循下列事项。

- 请勿在存储盒中放入导电的切屑、铁钉、钢丝、铜线或其他导线。
- 或者将电池装在电动工具中，或者在牢固按入电池盖并挡住通风孔后再存放，以防止短路（参照图 1）。



图 1

锂离子电池运输

当运输一个锂离子电池，请注意以下预防措施。

警告！

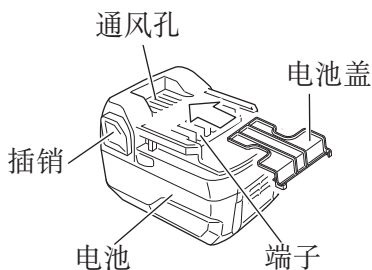
告知运输公司，包装内包含一个锂离子电池，告知该公司其功率输出并且要按照运输公司的指引安排运输。

- 功率输出超过100Wh的锂离子电池被视作危险物品运输分类并且需要特别申请程序。
- 对于境外运输，您必须遵守国际法以及输入国的规章和条例。



图 2

符号

警告！

如下所示的符号用于本机。使用前请务必理解其含意。

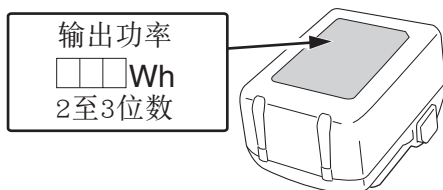
	为降低伤害风险，用户必须阅读使用说明书	n_0	空载转速
	直流电	/min	每分钟的振动次数
V	额定电压		警告

零件名称

1. 充电式冲击扳手 (WR18DF)

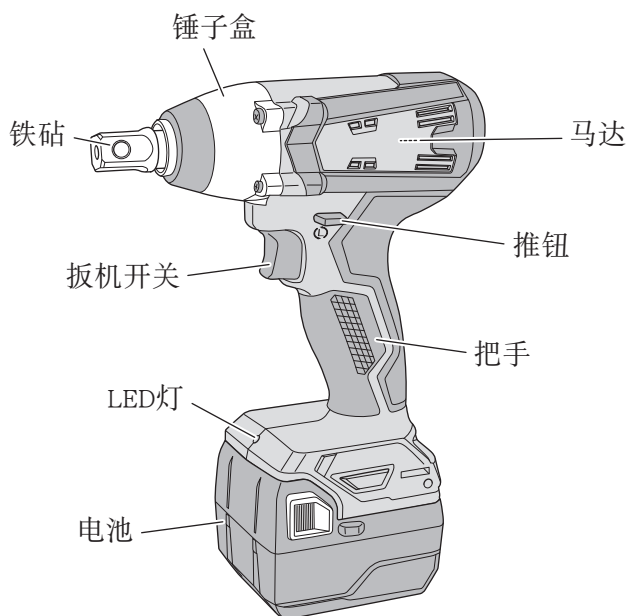

<WR18DF>

图 3

2. 电池

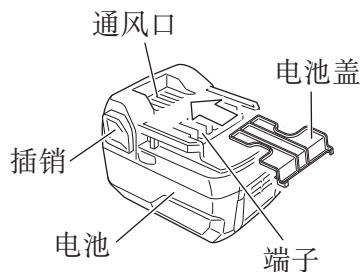

<BSL1850C>

图 4

3. 充电器

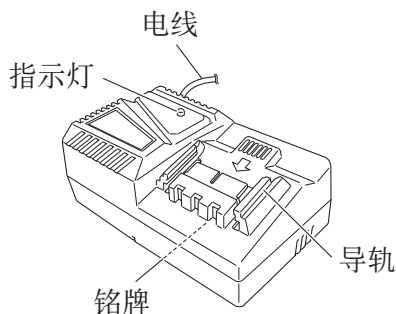

<UC18YFSL>

图 5

规格

电动工具

型式	WR18DF	
电压	18V	
无负荷速度	0-2400 转/分	
能力	普通螺栓	M10-M16
	高抗拉螺栓	M8-M14
旋紧扭矩 (最大)	220N·m	
充电式电池	BSL1850C: 锂离子18V (5.0Ah 5节)	
重量	1.6kg (安装 BSL1850C)	

充电器

型式	UC18YFSL
充电电压	14.4V-18V
重量	0.5kg

标准附件

除了主机 (1台) 外, 产品包中还包括表中所列的附件。

表 1

	WR18DF	
	(2JAK)	(NN)
 充电器 (UC18YFSL)	1	—
 电池 (BSL1850C)	2	—
 箱子	1	—
 电池盖	1	—

用途

拧紧和旋松用于固定结构部件的任何类型的螺栓和螺母

电池的拆卸 / 安装法

1. 电池的拆卸法

请先紧抓住把手、然后再推压电池插销以拆下电池 (参照图 6)。

注意!

切勿使电池短路。

2. 电池的安装法

插入电池时请注意极性 (参照图 6)



图 6

- 电池温度和充电时间相关资料。
温度和充电时间如表 3 所示

表 3

电池 \ 充电器		UC18YFSL
充电电压	V	14.4 - 18
重量	kg	0.5
电池可充电温度		0°C - 50°C
电池容量的大致充电时间 (20°C 下)		
1.5Ah	分钟	22
2.0Ah	分钟	30
2.5Ah	分钟	35
3.0Ah	分钟	45
4.0Ah	分钟	60
5.0Ah	分钟	75
6.0Ah	分钟	90
8.0Ah	分钟	120
电池数		4 - 10

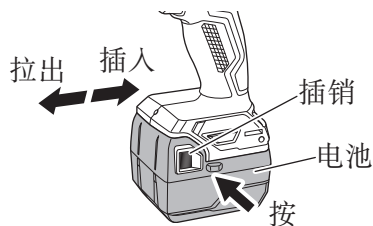
注：

充电时间可能根据环境温度和电压而有变化。

注意！

连续使用时，电池充电器温度将提升，因此会导致出现故障。完成充电后，下次充电前，请让电池充电器休息 15 分钟。

4. 从电源插座拔下充电器的电源线。
5. 握紧充电器并取出电池。

注：

充电后，先将电池从充电器中取出，然后妥善保存。

关于新电池的放电。

新电池内部的化学物质未被激活或电池长时间不使用时，初次或第二次使用时需要将其放电至较低电量。这只是暂时现象，将电池充电 2-3 次即可恢复为充电所需的正常时间。

较长时间保持电池性能的方法

- (1) 在电池电力完全耗尽之前进行充电。

感到电动工具的能力变弱时，请停止使用并给电池充电。若您继续使用电动工具并耗尽电力，电池可能会损坏或其使用寿命缩短。

(2) 避免在高温环境中充电。

使用后可充电电池的温度将迅速升高。若使用后立即对这种电池进行充电，其内部化学物质会劣化，电池使用寿命将缩短。请稍等片刻，待电池冷却后再进行充电。

注意！

- 如果电池长时间放置在阳光直接照射的地方或者刚刚使用完毕时，电池会变热。如果此时对电池充电，充电器上的指示灯会点亮 1 秒钟，不点亮 0.5 秒钟（熄灭 0.5 秒钟）。

在此情况下，先让电池冷却下来，然后再充电。

- 指示灯闪动时（以 0.2 秒钟的间隔），请检查并取出充电器电池接口处的任何异物。若无异物，则可能电池或充电器发生故障。请带去经授权的维修中心检查。
- 如果指示灯未以红色闪烁（每秒一次），但充电电池电源线已连接至电源，表明充电器的保护电路可能已激活。

拔下电源线或插座，然后等待 5 分钟左右再次连接。如果指示灯仍未以红色闪烁（每秒一次），请将充电器送还至HiKOKI授权服务中心。

作业之前

1. 准备和检查工作环境

确认工作场所满足使用注意事项中所述的所有条件。

2. 检查电池

确认已紧紧装上电池。如果松弛则电池可能会脱开，并造成事故。

3. 选择适合螺栓的套筒

使用的套筒务必适合要拧紧的螺栓。使用不适合的套筒不仅不能充分拧紧，还会损伤套筒或螺母。

磨损或变形的六角或方孔套筒不能为螺母或铁砧提供适当的固定拧紧力，从而导致拧紧扭矩的损失。

请注意套筒孔的磨损，并在进一步磨损前更换。

4. 安装套筒

选择要使用的套筒。

将位于铁砧方形部分内的活塞与六角套筒内的孔对齐。然后推活塞，将六角套筒装在铁砧上。（图 8）

确认活塞在孔内完全啮合。

要拆卸套筒时，请按相反步骤操作。



图 8

注意！

- 请使用操作手册和HiKOKI商品说明书中指定的附件。

否则可能会导致事故或受伤。

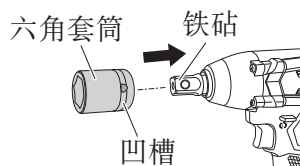
- 务必将套筒紧紧装入铁砧。否则套筒可能会脱落，并造成受伤。

使用方法

1. 检查旋转方向

按推钮的 R（右）侧，铁砧便会顺时针（从后方看时）旋转；按推钮的 L（左）侧则使铁砧逆时针旋转。（请参照图 9）。（机身上标有（L）和（R）标记。）



图 9

注意！

工具运转时，无法切换推钮。如需切换推钮，将工具停止运转后再切换推钮。

2. 开关操作

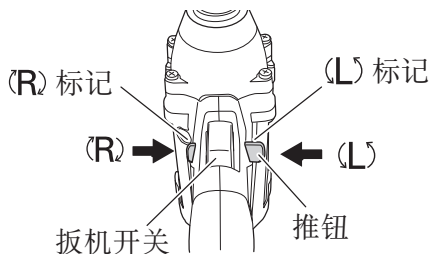
- 压下扳机开关，则本机旋转；松开扳机，则本机停止。
- 本机的转速可通过改变扳机开关的扣动幅度来控制。幅度小则速度低，幅度大则速度高。
- 松开开关的扳机时，制动器将立即停止。

注：

当马达即将起转时，可能会产生一种嗡嗡声。这只不过是一种噪音，而非机器故障。

3. 使用LED灯

扳动扳机开关使LED灯点亮。扳机开关处于扳动状态时，LED灯一直点亮。松开扳机开关后，LED灯熄灭。（图 10）



图 10

注意！

- 请不要直视灯光，避免眼睛直接受灯光照射。
如果眼睛持续受灯光照射，会伤害眼睛。
- 用软布仔细擦拭附着在LED灯镜片上的灰尘或污垢，小心不要划伤镜片。
如果划伤LED灯的镜片，可能会导致亮度减弱。

4. 拧紧和拧松螺栓

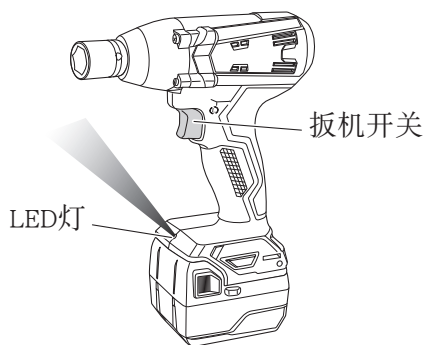
首先必须选择与螺栓或螺母相对应的六角扳手。接下来，将套筒安装到铁钻上，用六角扳手咬住要拧紧的螺母。

将扳手按在螺栓上，按电源开关冲击螺母几秒钟。

如果螺母松动地安装到螺栓上，螺栓可能随着螺母转动，则说明未正确拧紧。在此情况下，停止冲击螺母，用扳手按住螺母头后重新启动冲击，或者手动拧紧螺栓和螺母，以防它们滑动。

5. 使用挂钩（选购附件）

挂钩用于在工作时将电动工具挂到腰带上。

注意！

- 使用挂钩时，牢固挂好挂钩，以防意外掉落。如果电动工具掉落，可能造成意外伤害。
- 当选择将本工具挂在腰带上时，请确保拆下工具的刀头。否则将会带来无法预计的伤害。
- 将挂钩安装牢固。如果安装不牢固，在使用时可能造成伤害。

(1) 重新装上挂钩并拧紧螺丝。

将挂钩牢固安装到电动工具的凹槽中，拧紧螺丝固定挂钩。（图 11）

(2) 卸下挂钩。

用十字螺丝刀卸下用于固定挂钩的螺丝。（图 12）



图 11



图 12

操作上的注意事项

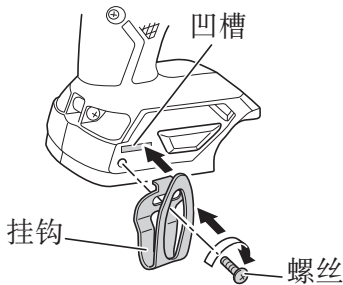
1. 连续作业后须让电动工具休息片刻

在连续进行螺栓紧固作业后以及在更换电池后，请让电动工具暂停作业 15 分钟。如果在更换电池后立刻开始作业，马达和开关等的温度将会升高，结果导致烧毁。

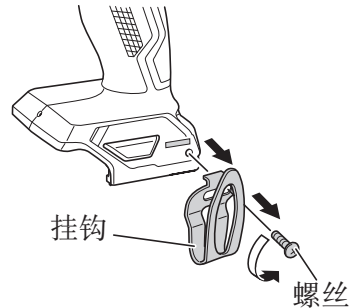
注意！

请勿触摸金属部件，它们在连续工作后可能高温。

2. 关于转速控制开关的注意事项

此开关带有可无级改变转速的内置电路。因此，当轻按启动开关（低速转动）并在连续旋转后，马达停止转动时，电路部分的元件可能会因过热而损坏。

3. 以适于受冲击螺栓的旋紧扭矩进行操作

螺栓和螺母最适宜的旋紧扭矩因螺栓或螺母的材料和尺寸而有所不同。对小螺栓使用过大的旋紧扭矩会扭曲或损坏螺栓。旋紧扭矩的增加与操作时间成正比。请使用正确的螺栓操作时间。

4. 握住工具

请用双手牢牢握住冲击扳手。在这种情况下，请与螺栓成直线地握住扳手。无需用力推扳手。
用足以抵消冲击力的力握住扳手。

5. 确定旋紧扭矩

下列因素会造成旋紧扭矩的下降。因此请在工作前用手工扭矩扳手来确定上紧螺栓所需的实际旋紧扭矩。影响旋紧扭矩的因素如下。

(1) 电压

达到放电极限时，电压降低，旋紧扭矩也减少。

(2) 操作时间

操作时间增加时旋紧扭矩也增加。但是，即使工具驱动很长的一段时间，旋紧扭矩也不会增大到超过某个特定值。

(3) 螺栓的直径

旋紧扭矩根据螺栓的直径变化。一般来说较大直径的螺栓需要较大的旋紧扭矩。

(4) 旋紧的状态

即使使用相同尺寸螺纹的螺栓，旋紧扭矩根据螺栓的扭矩比率、等级和长度也各不相同。旋紧扭矩还因螺栓所要上紧的加工件的表面状况而有所不同。螺栓和螺母一起转动时，扭矩会大大减少。

(5) 使用选购部件

使用接杆、万向接头或长套筒时拧紧扭矩略小一些。

(6) 套筒间隙

磨损或变形的六角或方孔套筒不能在螺母或铁砧之间提供适当的固定拧紧力，从而导致拧紧扭矩的损失。

使用不适合于螺栓的套筒会导致拧紧扭矩不足。

(7) 拧紧扭矩因电池充电程度而异。

维护和检查

警告！

为避免发生严重事故，请确保开关处于关断位置，并取出电池。

1. 检查套筒
磨损或变形的六角或方孔套筒不能在螺母或铁砧之间提供适当的固定拧紧力，从而导致拧紧扭矩的损失。
请定期检查套筒孔的磨损程度，如有需要换成新的。
2. 检查安装螺钉
要经常检查安装螺钉是否紧固妥善。若发现螺钉松了，应立即重新拧紧，否则会导致严重的事故。
3. 电动机的维护
电动机绕线是电动工具的“心脏部”应仔细检查有无损伤，是否被油液或水沾湿。
4. 检查端子（工具和电池）
确保端子上没有堆积削屑和灰尘。
在操作前、操作时和操作后需要时常检查。

注意！

请清除端子上的削屑或灰尘。
否则可能导致故障。

5. 清理外部
冲击扳手沾污时，用干软布或沾肥皂水的布擦拭。切勿使用氯溶液、汽油或稀释剂，以免塑胶部分溶化。
6. 收藏
冲击扳手应收藏于温度低于40℃和小孩拿不到的地方。

注:

存放锂离子电池

在存放前请确保电池已完全充电。

电池在低电量的状态下长时间存放（3个月或更长），可能会导致电池性能劣化，使用时间明显减少或无法进行充电。

但是，即使是使用时间明显减少的电池，通过反复充电和使用2—5次，有时也可恢复使用时间。

若反复充电和使用后电池的使用时间仍非常短，请认作为电池已达到了使用寿命并更换新的电池。

注意！

在操作和维修电动工具时，必须遵守贵国制定的安全的有关规则 and 标准。

关于HiKOKI牌无线电动工具的重要通知：

请确保始终使用我们指定的正版电池。如果使用我们指定以外的电池，或对电池进行拆卸和改动（例如拆卸和更换电池组件或其他内部部件），那么我们无法保证我们无线电动工具的安全性和使用性能。

选择附件

根据特定作业选择适合的附件。

有关详细信息请联系HiKOKI授权服务中心。

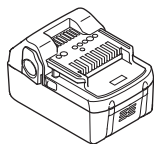

18V (锂离子)
电池

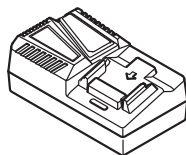

UC18YFSL (14.4V-18V)
充电器

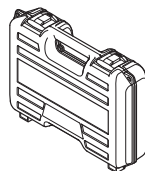

产品编号: 336642
箱子

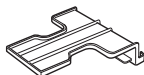

产品编号: 329897
电池盖

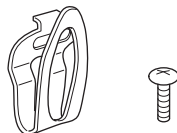

产品编号: 375800
挂钩组

CONTENTS

GENERAL POWER TOOL SAFETY WARNINGS	19
CORDLESS IMPACT WRENCH SAFETY WARNINGS	22
CAUTION ON LITHIUM-ION BATTERY	23
REGARDING LITHIUM-ION BATTERY TRANSPORTATION	25
SYMBOLS	25
NAME OF PARTS.....	26
SPECIFICATIONS	27
STANDARD ACCESSORIES	27
APPLICATIONS.....	28
BATTERY REMOVAL/INSTALLATION	28
CHARGING	28
PRIOR TO OPERATION.....	31
HOW TO USE.....	31
OPERATIONAL CAUTIONS.....	33
MAINTENANCE AND INSPECTION	34
SELECTING ACCESSORIES.....	36

GENERAL POWER TOOL SAFETY WARNINGS

WARNING

Read all safety warnings and all instructions.

Failure to follow the warnings and instructions may result in electric shock, fire and/or serious injury.

Save all warnings and instructions for future reference.

The term “power tool” in the warnings refers to your mains-operated (corded) power tool or battery-operated (cordless) power tool.

- 1) **Work area safety**
 - a) **Keep work area clean and well lit.**
Cluttered or dark areas invite accidents.
 - b) **Do not operate power tools in explosive atmospheres, such as in the presence of flammable liquids, gases or dust.**
Power tools create sparks which may ignite the dust or fumes.
 - c) **Keep children and bystanders away while operating a power tool.**
Distractions can cause you to lose control.
- 2) **Electrical safety**
 - a) **Power tool plugs must match the outlet.**
Never modify the plug in any way.
Do not use any adapter plugs with earthed (grounded) power tools.
Unmodified plugs and matching outlets will reduce risk of electric shock.

English

- b) **Avoid body contact with earthed or grounded surfaces, such as pipes, radiators, ranges and refrigerators.**

There is an increased risk of electric shock if your body is earthed or grounded.

- c) **Do not expose power tools to rain or wet conditions.**

Water entering a power tool will increase the risk of electric shock.

- d) **Do not abuse the cord. Never use the cord for carrying, pulling or unplugging the power tool.**

Keep cord away from heat, oil, sharp edges or moving parts.

Damaged or entangled cords increase the risk of electric shock.

- e) **When operating a power tool outdoors, use an extension cord suitable for outdoor use.**

Use of a cord suitable for outdoor use reduces the risk of electric shock.

- f) **If operating a power tool in a damp location is unavoidable, use a residual current device (RCD) protected supply.**

Use of an RCD reduces the risk of electric shock.

3) **Personal safety**

- a) **Stay alert, watch what you are doing and use common sense when operating a power tool.**

Do not use a power tool while you are tired or under the influence of drugs, alcohol or medication.

A moment of inattention while operating power tools may result in serious personal injury.

- b) **Use personal protective equipment. Always wear eye protection.**

Protective equipment such as dust mask, non-skid safety shoes, hard hat, or hearing protection used for appropriate conditions will reduce personal injuries.

- c) **Prevent unintentional starting. Ensure the switch is in the off position before connecting to power source and/or battery pack, picking up or carrying the tool.**

Carrying power tools with your finger on the switch or energising power tools that have the switch on invites accidents.

- d) **Remove any adjusting key or wrench before turning the power tool on.**

A wrench or a key left attached to a rotating part of the power tool may result in personal injury.

- e) **Do not overreach. Keep proper footing and balance at all times.**

This enables better control of the power tool in unexpected situations.

- f) **Dress properly. Do not wear loose clothing or jewellery. Keep your hair, clothing and gloves away from moving parts.**

Loose clothes, jewellery or long hair can be caught in moving parts.

- g) **If devices are provided for the connection of dust extraction and collection facilities, ensure these are connected and properly used.**

Use of dust collection can reduce dust-related hazards.

4) **Power tool use and care**

- a) **Do not force the power tool. Use the correct power tool for your application.**

The correct power tool will do the job better and safer at the rate for which it was designed.

- b) **Do not use the power tool if the switch does not turn it on and off.**
Any power tool that cannot be controlled with the switch is dangerous and must be repaired.
- c) **Disconnect the plug from the power source and/or the battery pack from the power tool before making any adjustments, changing accessories, or storing power tools.**
Such preventive safety measures reduce the risk of starting the power tool accidentally.
- d) **Store idle power tools out of the reach of children and do not allow persons unfamiliar with the power tool or these instructions to operate the power tool.**
Power tools are dangerous in the hands of untrained users.
- e) **Maintain power tools. Check for misalignment or binding of moving parts, breakage of parts and any other condition that may affect the power tool's operation.**
If damaged, have the power tool repaired before use.
Many accidents are caused by poorly maintained power tools.
- f) **Keep cutting tools sharp and clean.**
Properly maintained cutting tools with sharp cutting edges are less likely to bind and are easier to control.
- g) **Use the power tool, accessories and tool bits etc. in accordance with these instructions, taking into account the working conditions and the work to be performed.**
Use of the power tool for operations different from those intended could result in a hazardous situation.

5) Battery tool use and care

- a) **Recharge only with the charger specified by the manufacturer.**
A charger that is suitable for one type of battery pack may create a risk of fire when used with another battery pack.
- b) **Use power tools only with specifically designated battery packs.**
Use of any other battery packs may create a risk of injury and fire.
- c) **When battery pack is not in use, keep it away from other metal objects, like paper clips, coins, keys, nails, screws or other small metal objects, that can make a connection from one terminal to another.**
Shorting the battery terminals together may cause burns or a fire.
- d) **Under abusive conditions, liquid may be ejected from the battery; avoid contact. If contact accidentally occurs, flush with water. If liquid contacts eyes, additionally seek medical help.**
Liquid ejected from the battery may cause irritation or burns.

6) Service

- a) **Have your power tool serviced by a qualified repair person using only identical replacement parts.**
This will ensure that the safety of the power tool is maintained.

CAUTION

Keep children and infirm persons away.

When not in use, tools should be stored out of reach of children and infirm persons.

CORDLESS IMPACT WRENCH SAFETY WARNINGS

1. Hold power tool by insulated gripping surfaces, when performing an operation where the fastener may contact hidden wiring. Fasteners contacting a “live” wire may make exposed metal parts of the power tool “live” and could give the operator an electric shock.
2. This is a portable tool for tightening and loosening bolts and nuts. Use it only for these operations.
3. Use the earplugs if using for a long time.
4. One-hand operation is extremely dangerous; hold the unit firmly with both hands when operating.
5. Check that the socket is not cracked or broken. Broken or cracked sockets are dangerous. Check the socket before using it.
6. Secure the socket with the socket pin and the ring.
If the socket pin or ring securing the socket is damaged, the socket may come off from the impact wrench, which is quite dangerous. Do not use socket pins or rings that are deformed, worn out, cracked, or in any other way damaged. Always make sure to install the socket pin and ring in the correct position.
7. Check the tightening torque.
The appropriate torque for tightening a bolt depends on the material the bolt is made of, its dimensions, grade, etc.
Also, the tightening torque generated by this impact wrench depends on the materials and dimensions of the bolt, how long the impact wrench is applied for the way in which the socket is installed, etc.
Also the torque when the battery has just been charged and when it is about to run out are slightly different. Use a torque wrench to check that the bolt has been tightened with the appropriate torque.
8. Stop the impact wrench before switching the direction of rotation. Always release the switch and wait for impact wrench to stop before switching the direction of rotation.
9. Never touch the turning part.
Do not allow the turning socket section to get near your hands or any other part of your body. You could be cut or caught in the socket. Also, be careful not to touch the socket after using continuously it for a long time. It gets quite hot and could burn you.
10. Never let the impact wrench turn without a load when using the universal joint.
If the socket turns without being connected to a load, the universal joint causes the socket to turn wildly. You could get hurt or the movement of the socket could shake the impact wrench so much as to make you drop it.
11. Always charge the battery at a temperature of 0–40°C.
A temperature of less than 0°C will result in over charging which is dangerous. The battery cannot be charged at a temperature greater than 40°C.
The most suitable temperature for charging is that of 20–25°C.

12. Do not use the charger continuously.
When one charging is completed, leave the charger for about 15 minutes before the next charging of battery.
13. Do not allow foreign matter to enter the hole for connecting the rechargeable battery.
14. Never disassemble the rechargeable battery and charger.
15. Never short-circuit the rechargeable battery.
Short-circuiting the battery will cause a great electric current and overheat. It results in burn or damage to the battery.
16. Do not dispose of the battery in fire.
If the battery burnt, it may explode.
17. Do not insert object into the air ventilation slots of the charger.
Inserting metal objects or inflammables into the charger air ventilation slots will result in electrical shock hazard or damaged charger.
18. Bring the battery to the shop from which it was purchased as soon as the post-charging battery life becomes too short for practical use. Do not dispose of the exhausted battery.
19. Do not use the product if the tool or the battery terminals (battery mount) are deformed.
Installing the battery could cause a short circuit that could result in smoke emission or ignition.
20. Keep the tool's terminals (battery mount) free of swarf and dust.
 - Prior to use, make sure that swarf and dust have not collected in the area of the terminals.
 - During use, try to avoid swarf or dust on the tool from falling on the battery.
 - When suspending operation or after use, do not leave the tool in an area where it may be exposed to falling swarf or dust.
Doing so could cause a short circuit that could result in smoke emission or ignition.

CAUTION ON LITHIUM-ION BATTERY

To extend the lifetime, the lithium-ion battery equips with the protection function to stop the output.

In the cases of 1 to 3 described below, when using this product, even if you are pulling the switch, the motor may stop. This is not the trouble but the result of protection function.

1. When the battery power remaining runs out, the motor stops.
In such case, charge it up immediately.
2. If the tool is overloaded, the motor may stop. In this case, release the switch of tool and eliminate causes of overloading. After that, you can use it again.
3. If the battery is overheated under overload work, the battery power may stop.
In this case, stop using the battery and let the battery cool. After that, you can use it again.

Furthermore, please heed the following warning and caution.

WARNING

In order to prevent any battery leakage, heat generation, smoke emission, explosion and ignition beforehand, please be sure to heed the following precautions.

English

1. Make sure that swarf and dust do not collect on the battery.
 - During work make sure that swarf and dust do not fall on the battery.
 - Make sure that any swarf and dust falling on the power tool during work do not collect on the battery.
 - Do not store an unused battery in a location exposed to swarf and dust.
 - Before storing a battery, remove any swarf and dust that may adhere to it and do not store it together with metal parts (screws, nails, etc.).
2. Do not pierce battery with a sharp object such as a nail, strike with a hammer, step on, throw or subject the battery to severe physical shock.
3. Do not use an apparently damaged or deformed battery.
4. Do not use the battery in reverse polarity.
5. Do not connect directly to an electrical outlets or car cigarette lighter sockets.
6. Do not use the battery for a purpose other than those specified.
7. If the battery charging fails to complete even when a specified recharging time has elapsed, immediately stop further recharging.
8. Do not put or subject the battery to high temperatures or high pressure such as into a microwave oven, dryer, or high pressure container.
9. Keep away from fire immediately when leakage or foul odor are detected.
10. Do not use in a location where strong static electricity generates.
11. If there is battery leakage, foul odor, heat generated, discolored or deformed, or in any way appears abnormal during use, recharging or storage, immediately remove it from the equipment or battery charger, and stop use.
12. Do not immerse the battery or allow any fluids to flow inside. Conductive liquid ingress, such as water, can cause damage resulting in fire or explosion. Store your battery in a cool, dry place, away from combustible and flammable items. Corrosive gas atmospheres must be avoided.

CAUTION

1. If liquid leaking from the battery gets into your eyes, do not rub your eyes and wash them well with fresh clean water such as tap water and contact a doctor immediately. If left untreated, the liquid may cause eye-problems.
2. If liquid leaks onto your skin or clothes, wash well with clean water such as tap water immediately.
There is a possibility that this can cause skin irritation.
3. If you find rust, foul odor, overheating, discolor, deformation, and/or other irregularities when using the battery for the first time, do not use and return it to your supplier or vendor.

WARNING

If an electrically conductive foreign object enters the terminals of the lithium ion battery, a short-circuit may occur resulting in the risk of fire. Please observe the following matters when storing the battery.

- Do not place electrically conductive cuttings, nails, steel wire, copper wire or other wire in the storage case.

- Either install the battery in the power tool or store by securely pressing into the battery cover until the ventilation holes are concealed to prevent short-circuits (See Fig. 1).

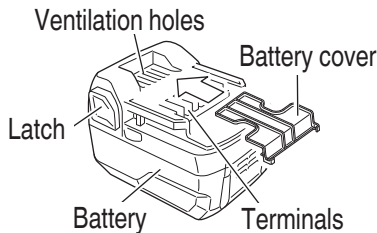

Fig. 1

REGARDING LITHIUM-ION BATTERY TRANSPORTATION

When transporting a lithium-ion battery, please observe the following precautions.

WARNING

Notify the transporting company that a package contains a lithium-ion battery, inform the company of its power output and follow the instructions of the transportation company when arranging transport.

- Lithium-ion batteries that exceed a power output of 100 Wh are considered to be in the freight classification of Dangerous Goods and will require special application procedures.
- For transportation abroad, you must comply with international law and the rules and regulations of the destination country.

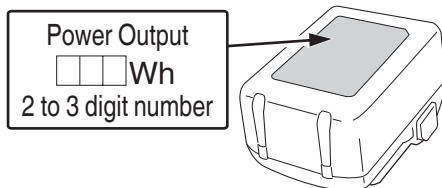





Fig. 2

SYMBOLS

WARNING

The following show symbols used for the machine. Be sure that you understand their meaning before use.

	To reduce the risk of injury, user must read instruction manual.	n_0	No-load speed
	Direct current	/min	Oscillation per minute
V	Rated voltage		Warning

NAME OF PARTS

1. Cordless Impact Wrench (WR18DF)

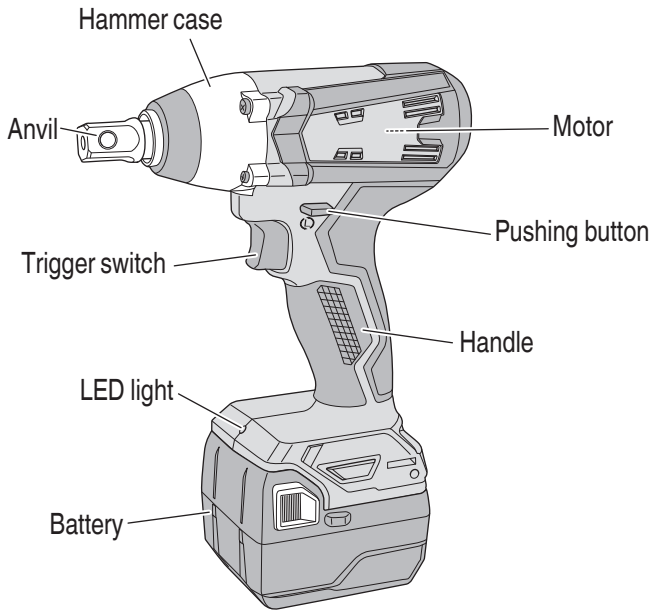

<WR18DF>
Fig. 3

2. Battery

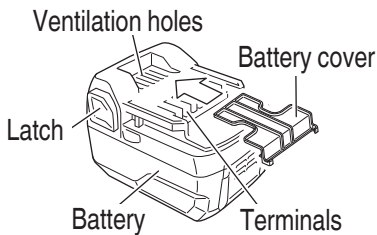

<BSL1850C>
Fig. 4

3. Battery Charger

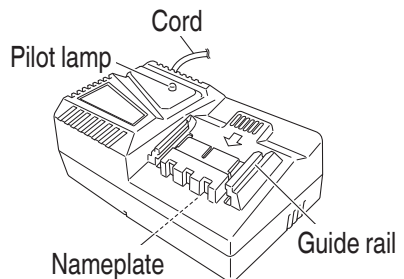

<UC18YFSL>
Fig. 5

SPECIFICATIONS

POWER TOOL

Model		WR18DF
Voltage		18 V
No-load speed		0–2400 /min
Capacity	Ordinary bolt	M10–M16
	High tension bolt	M8–M14
Tightening torque (Maximum)		220 N·m
Rechargeable battery		BSL1850C: Li-ion 18 V (5.0 Ah 5 cells)
Weight		1.6 kg (BSL1850C attached)



CHARGER

Model	UC18YFSL
Charging voltage	14.4 V–18 V
Weight	0.5 kg

STANDARD ACCESSORIES

In addition to the main unit (1 unit), the package contains the accessories listed in the below.

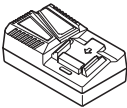
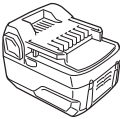
Table 1

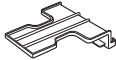
		WR18DF	
		(2JAK)	(NN)
	Charger (UC18YFSL)	1	—
	Battery (BSL1850C)	2	—
	Case	1	—
	Battery cover	1	—

APPLICATIONS

Tightening and loosening of all types of bolts and nuts, used for securing structural items.

BATTERY REMOVAL/INSTALLATION

1. Battery removal
Hold the handle tightly and push the battery latch to remove the battery (see **Fig. 6**).

CAUTION

Never short-circuit the battery.

2. Battery installation
Insert the battery while observing its polarities (see **Fig. 6**).

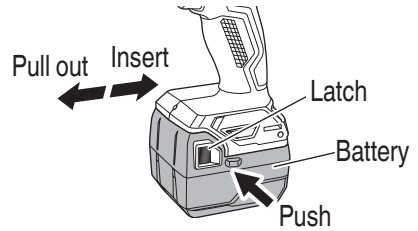

Fig. 6

CHARGING

Before using the power tool, charge the battery as follows.

1. Connect the charger's power cord to the receptacle.
When connecting the plug of the charger to a receptacle, the pilot lamp will blink in red (At 1- second intervals).
2. Insert the battery into the charger.
Firmly insert the battery into the charger as shown in **Fig. 7**.
3. Charging
When inserting a battery in the charger, charging will commence and the pilot lamp will light continuously in red.
When the battery becomes fully recharged, the pilot lamp will blink in red. (At 1-second intervals) (See **Table 2**)

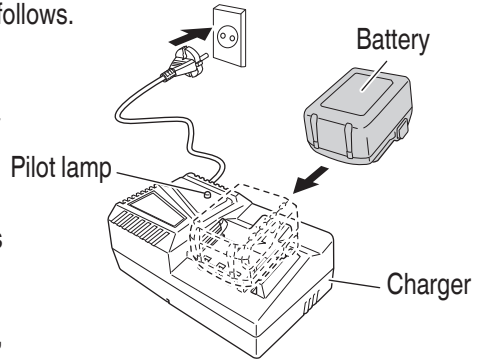







Fig. 7

- Pilot lamp indication

The indications of the pilot lamp will be as shown in **Table 2**, according to the condition of the charger or the rechargeable battery.

Table 2

Indications of the pilot lamp				
Pilot lamp (red)	Before charging	Blinks	Lights for 0.5 seconds. Does not light for 0.5 seconds. (off for 0.5 seconds) 	Plugged into power source
	While charging	Lights	Lights continuously 	
	Charging complete	Blinks	Lights for 0.5 seconds. Does not light for 0.5 seconds. (off for 0.5 seconds) 	
	Overheat standby	Blinks	Lights for 1 second. Does not light for 0.5 seconds. (off for 0.5 seconds) 	Battery overheated. Unable to charge. (Charging will commence when battery cools)
	Charging impossible	Flickers	Lights for 0.1 seconds. Does not light for 0.1 seconds. (off for 0.1 seconds) 	Malfunction in the battery or the charger

- Regarding the temperatures and charging time of the battery.

The temperatures and charging time will become as shown in **Table 3**.

Table 3

Battery	Charger	UC18YFSL
Charging voltage	V	14.4-18
Weight	kg	0.5
Temperatures at which the battery can be recharged		0°C-50°C
Charging time for battery capacity, approx. (At 20°C)		
1.5 Ah	min	22
2.0 Ah	min	30
2.5 Ah	min	35
3.0 Ah	min	45
4.0 Ah	min	60
5.0 Ah	min	75
6.0 Ah	min	90
8.0 Ah	min	120
Number of battery cells		4-10

English

NOTE

The recharging time may vary according to temperature and power source voltage.

CAUTION

When the battery charger has been continuously used, the battery charger will be heated, thus constituting the cause of the failures. Once the charging has been completed, give 15 minutes rest until the next charging.

4. Disconnect the charger's power cord from the receptacle.
5. Hold the charger firmly and pull out the battery.

NOTE

Be sure to pull out the battery from the charger after use, and then keep it.

Regarding electric discharge in case of new batteries, etc.

As the internal chemical substance of new batteries and batteries that have not been used for an extended period is not activated, the electric discharge might be low when using them the first and second time. This is a temporary phenomenon, and normal time required for recharging will be restored by recharging the batteries 2–3 times.

How to make the batteries perform longer.

- (1) Recharge the batteries before they become completely exhausted.
When you feel that the power of the tool becomes weaker, stop using the tool and recharge its battery. If you continue to use the tool and exhaust the electric current, the battery may be damaged and its life will become shorter.
- (2) Avoid recharging at high temperatures.
A rechargeable battery will be hot immediately after use. If such a battery is recharged immediately after use, its internal chemical substance will deteriorate, and the battery life will be shortened. Leave the battery and recharge it after it has cooled for a while.

CAUTION

- If the battery is charged while it is heated because it has been left for a long time in a location subject to direct sunlight or because the battery has just been used, the pilot lamp of the charger lights for 1 second, does not light for 0.5 seconds (off for 0.5 seconds). In such a case, first let the battery cool, then start charging.
- When the pilot lamp flickers (at 0.2-second intervals), check for and take out any foreign objects in the charger's battery connector. If there are no foreign objects, it is probable that the battery or charger is malfunctioning. Take it to your authorized Service Center.
- If the pilot lamp does not blink in red (every second) even though the charger cord is connected to the power, it indicates that the protection circuit of the charger may be activated.

Remove the cord or plug from the power and then connect it again after 5 minutes or so. If this does not cause the pilot lamp to blink in red (every second), please take the charger to the HiKOKI Authorized Service Center.

PRIOR TO OPERATION

1. Preparing and checking the work environment
Make sure that the work site meets all the conditions laid forth in the precautions.
2. Checking the battery
Make sure that the battery is installed firmly. If it is at all loose it could come off and cause an accident.
3. Selecting the socket matched to the bolt
Be sure to use a socket which is matched to the bolt to be tightened. Using an improper socket will not only result in insufficient tightening but also in damage to the socket or nut. A worn or deformed hex. or square-holed socket will not give an adequate tightness for fitting to the nut or anvil, consequently resulting in loss of tightening torque. Pay attention to wear of socket hole, and replace before further wear has developed.
4. Installing a socket
Select the socket to be used.
Align the plunger located in the square part of the anvil with the hole in the hex. socket. Then push the plunger, and mount the hex. socket on the anvil. (Fig. 8)
Check that the plunger is fully engaged in the hole.
When removing the socket, reverse the sequence.

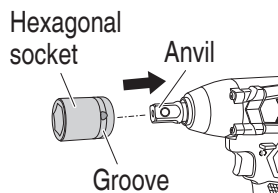

Fig. 8

CAUTION

- Please use the designated attachments which are listed in the operations manual and HiKOKI's catalog.
Accidents or injuries could result from not doing so.
- Make sure to firmly install the socket in the anvil. If the socket is not firmly installed it might come out and cause injuries.

HOW TO USE

1. Check the rotational direction
The anvil rotates clockwise (viewed from the rear side) by pushing the R-side of the pushing button.
The L-side of the pushing button is pushed to turn the anvil counterclockwise (See Fig. 9)
(The (L) and (R) marks are provided on the body).

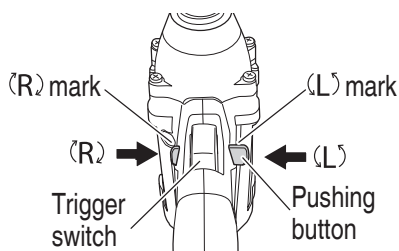

Fig. 9

CAUTION

The pushing button cannot be switched while the tool is turning. To switch the pushing button, stop the tool, then set the pushing button.

English

2. Switch operation

- When the trigger switch is depressed, the tool rotates. When the trigger is released, the tool stops.
- The rotational speed of the tool can be controlled by varying the amount that the trigger switch is pulled. Speed is low when the trigger switch is pulled slightly and increases as the trigger switch is pulled more.
- When releasing the trigger of the switch, the brake will be applied for immediate stopping.

NOTE

A buzzing noise is produced when the motor is about to rotate. This is only a noise, not a machine failure.

3. Using the LED light

Pull the trigger switch to light up the LED light.

The LED light keeps on lighting while the trigger switch is being pulled. The LED light goes out after releasing the trigger switch. (Fig. 10)

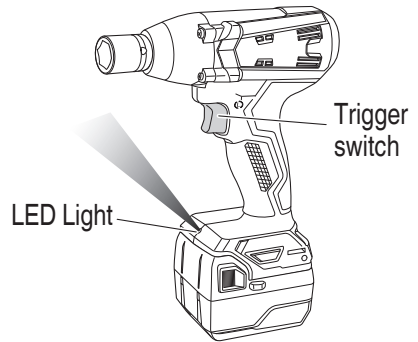

Fig. 10

CAUTION

- **Do not expose directly your eye to the light by looking into the light. If your eye is continuously exposed to the light, your eye will be hurt.**
- **Wipe off any dirt or grime attached to the lens of the LED light with a soft cloth, being careful not to scratch the lens. Scratches on the lens of the LED light can result in decreased brightness.**

4. Tightening and loosening bolts

A hex. socket matching the bolt or nut must first be selected. Then mount the socket on the anvil, and grip the nut to be tightened with the hex. socket. Holding the wrench in line with the bolt, press the power switch to impact the nut for several seconds.

If the nut is only loosely fitted to the bolt, the bolt may turn with the nut, therefore mistaking proper tightening. In this case, stop impact on the nut and hold the bolt head with a wrench before restarting impact, or manually tighten the bolt and nut to prevent them slipping.

5. Using the hook (optional accessory)

The hook is used to hang up the power tool to your waist belt while working.

CAUTION

- **When using the hook, hang up the power tool firmly not to drop accidentally. If the power tool is dropped, it may lead to an accident.**
- **When electing to carry the tool hooked to your hip belt, make sure to detach the tool bit. Failure to do so may result in unexpected injury.**
- **Install securely the hook. Unless the hook is securely installed, it may cause an injury while using.**

- (1) Replacing the hook and tightening the screws.
Install securely the hook in the groove of power tool and tighten the screws to fix the hook firmly. (Fig. 11)
- (2) Removing the hook.
Remove the screws fixing the hook with Philips screw driver. (Fig. 12)

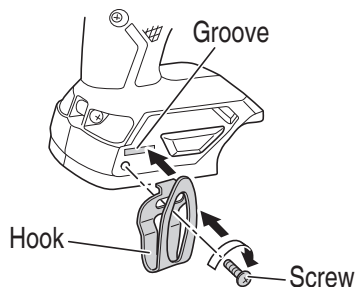

Fig. 11

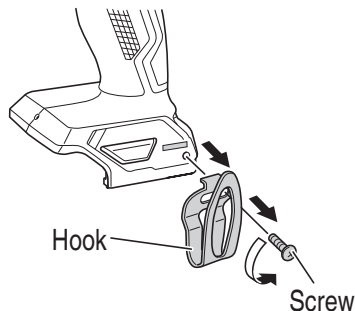

Fig. 12

OPERATIONAL CAUTIONS

1. Resting the unit after continuous work
After use for continuous bolt-tightening work, rest the unit for 15 minutes or so when replacing the battery. The temperature of the motor, switch, etc., will rise if the work is started again immediately after battery replacement, eventually resulting in burnout.

CAUTION

Do not touch the metal parts, as it gets very hot during continuous work.

2. Cautions on use of the speed control switch
This switch has a built-in, electronic circuit which steplessly varies the rotation speed. Consequently, when the switch trigger is pulled only slightly (low speed rotation) and the motor is stopped while continuously driving, the components of the electronic circuit parts may overheat and be damaged.
3. Work at a tightening torque suitable for the bolt under impact
The optimum tightening torque for nuts or bolts differs with material and size of the nuts or bolts. An excessively large tightening torque for a small bolt may stretch or break the bolt. The tightening torque increases in proportion to the operation time. Use the correct operating time for the bolt.
4. Holding the tool
Hold the impact wrench firmly with both hands. In this case hold the wrench in line with the bolt. It is not necessary to push the wrench very hard. Hold the wrench with a force just sufficient to counteract the impact force.

English

5. Confirm the tightening torque
The following factors contribute to a reduction of the tightening torque. So confirm the actual tightening torque needed by screwing up some bolts before the job with a hand torque wrench. Factors affecting the tightening torque are as follows.
 - (1) Voltage
When the discharge margin is reached, voltage decreases and tightening torque is lowered.
 - (2) Operating time
The tightening torque increases when the operating time increases. But the tightening torque does not increase above a certain value even if the tool is driven for a long time.
 - (3) Diameter of bolt
The tightening torque differs with the diameter of the bolt. Generally a larger diameter bolt requires larger tightening torque.
 - (4) Tightening conditions
The tightening torque differs according to the torque ratio; class, and length of bolts even when bolts with the same size threads are used. The tightening torque also differs according to the condition of the surface of workpiece through which the bolts are to be tightened. When the bolt and nut turn together, torque is greatly reduced.
 - (5) Using optional parts
The tightening torque is reduced a little when an extension bar, universal joint or a long socket is used.
 - (6) Clearance of the socket
A worn or deformed hex. or a square-holed socket will not give an adequate tightness to the fitting between the nut or anvil, consequently resulting in loss of tightening torque.
Using an improper socket which does not match to the bolt will result in an insufficient tightening torque.
 - (7) Tightening torque varies, depending on the battery's charge level.

MAINTENANCE AND INSPECTION

WARNING

To avoid serious accident, ensure the switch is in the OFF position, and pull out the battery.

1. Inspecting the socket
A worn or deformed hex. or a square-holed socket will not give an adequate tightness to the fitting between the nut or anvil, consequently resulting in loss of tightening torque. Pay attention to wear of a socket holes periodically, and replace with a new one if needed.
2. Inspecting the mounting screws
Regularly inspect all mounting screws and ensure that they are properly tightened. Should any of the screws be loose, retighten them immediately. Failure to do so may result in serious hazard.
3. Maintenance of the motor
The motor unit winding is the very "heart" of the power tool.
Exercise due care to ensure the winding does not become damaged and/or wet with oil or water.

4. Inspection of terminals (tool and battery)
Check to make sure that swarf and dust have not collected on the terminals.
On occasion check prior, during and after operation.

CAUTION

**Remove any swarf or dust which may have collected on the terminals.
Failure to do so may result in malfunction.**

5. Cleaning of the outside
When the impact wrench is stained, wipe with a soft dry cloth or a cloth moistened with soapy water. Do not use chloric solvents, gasoline or paint thinner, as they melt plastics.
6. Storage
Store the impact wrench in a place in which the temperature is less than 40°C, and out of reach of children.

NOTE

Storing Lithium-ion Batteries

Make sure the batteries have been fully charged before storing them.

Prolonged storage (3 months or more) of batteries with a low charge may result in performance deterioration, significantly reducing battery usage time or rendering the batteries incapable of holding a charge.

However, significantly reduced battery usage time may be recovered by repeatedly charging and using the batteries two to five times.

If the battery usage time is extremely short despite repeated charging and use, consider the batteries dead and purchase new batteries.

CAUTION

In the operation and maintenance of power tools, the safety regulations and standards prescribed in each country must be observed.

Important notice on the batteries for the HiKOKI cordless power tools

Please always use one of our designated genuine batteries. We cannot guarantee the safety and performance of our cordless power tool when used with batteries other than these designated by us, or when the battery is disassembled and modified (such as disassembly and replacement of cells or other internal parts).

SELECTING ACCESSORIES

Select accessories that are suited to a specific task.
For details contact HiKOKI Authorized Service Center.

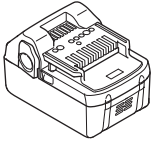

18 V (Li-ion)
Battery

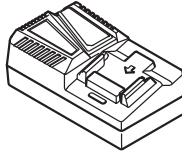

UC18YFSL (14.4 V-18 V)
Charger

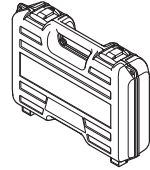

Part Number: 336642
Case

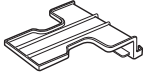

Part Number: 329897
Battery cover

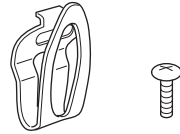

Part Number: 375800
Hook set

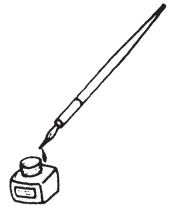

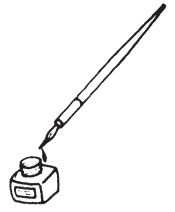

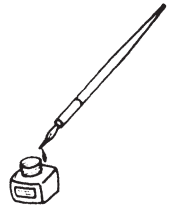

服务中心
高壹工机商业(上海)有限公司
上海市闵行区浦江工业园区三鲁路3585号7幢3楼

制造商
广东高壹工机有限公司
广东省广州市番禺区化龙镇工业路富裕围工业村

Koki Holdings Co., Ltd.

112
编号: C99743721 G
发行日期: 2021年 12月
中国印刷