

HiKOKI

充电式电圆锯
Cordless Circular Saw

中文
English

C 1807DA

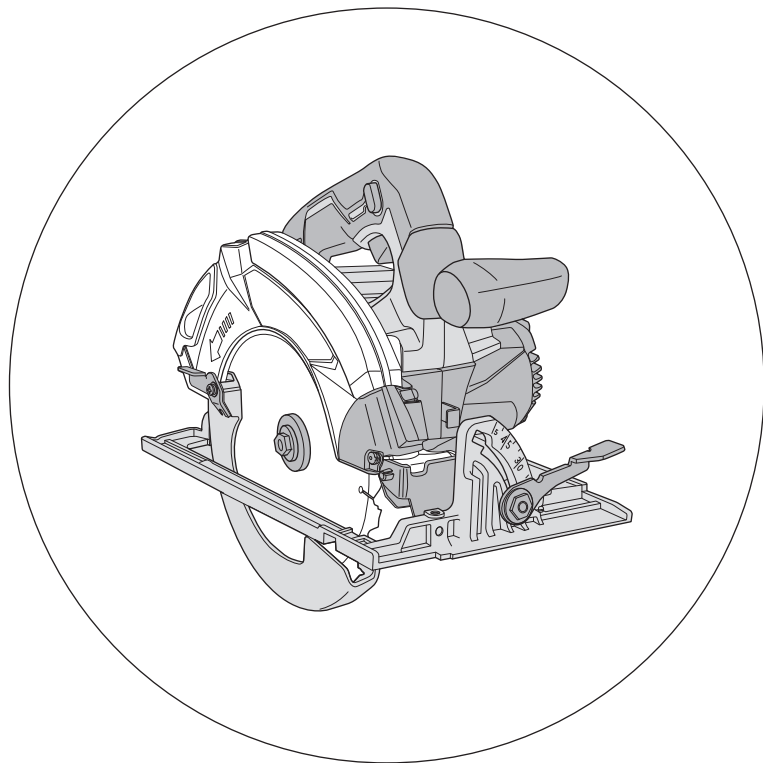

保留备用
Keep for future reference



使用说明书
Handling instructions

目次

电动工具通用安全警告.....	2	用途.....	13
所有圆锯的安全说明.....	4	电池的拆卸 / 安装法.....	13
对各种圆锯的进一步安全说明.....	5	充电.....	14
带摆动式内护罩的圆锯的安全说明.....	6	作业之前.....	16
使用电圆锯时的注意事项.....	6	使用前调整电圆锯.....	18
锂离子电池使用注意事项.....	8	操作.....	20
锂离子电池运输.....	10	LED 灯警示信号 (图 34).....	25
符号.....	10	维护和检查.....	25
零件名称.....	11	故障排除.....	28
规格.....	12	选择附件.....	29
标准附件.....	13		

电动工具通用安全警告

警告！

阅读所有警告和所有说明。

不遵照以下警告和说明会导致电击、着火和 / 或严重伤害。

保存所有警告和说明书以备查阅。

在所有下列的警告中术语“电动工具”指市电驱动（有线）电动工具或电池驱动（无线）电动工具。

1) 工作场地的安全

- a) 保持工作场地清洁和明亮。
混乱和黑暗的场地会引发事故。
- b) 不要在易爆环境，如有易燃液体、气体或粉尘的环境下操作电动工具。
电动工具产生的火花会点燃粉尘或气体。
- c) 让儿童和旁观者离开后操作电动工具。
注意力不集中会使操作者失去对工具的控制。

2) 电气安全

- a) 电动工具插头必须与插座相配。绝不能以任何方式改装插头。需接地的电动工具不能使用任何转换插头。
未经改装的插头和相配的插座将减少电击危险。
- b) 避免人体接触接地表面，如管道、散热片和冰箱。
如果你身体接地会增加电击危险。

- c) 不得将电动工具暴露在雨中或潮湿环境中。
水进入电动工具将增加电击危险。
- d) 不得滥用电线。绝不能用电线搬运、拉动电动工具或拔出其插头。使电线远离热源、油、锐边或运动部件。
受损或缠绕的软线会增加电击危险。
- e) 当在户外使用电动工具时，使用适合户外使用的外接软线。
适合户外使用的软线将减少电击危险。
- f) 如果在潮湿环境下操作电动工具是不可避免的，应使用剩余电流动作保护装置（RCD）。
使用RCD可减小电击危险。

3) 人身安全

- a) 保持警觉，当操作电动工具时关注所从事的操作并保持清醒。
当你感到疲倦，或在有药物、酒精或治疗反应时，不要操作电动工具。
在操作电动工具时瞬间的疏忽会导致严重人身伤害。
- b) 使用个人防护装置。始终佩戴护目镜。
安全装置，诸如适当条件下使用防尘面具、防滑安全鞋、安全帽、听力防护等装置能减少人身伤害。
- c) 防止意外起动。确保开关在连接电源和 / 或电池盒、拿起或搬运工具时处于关断位置。
手指放在已接通电源的开关上或开关处于接通时插入插头可能会导致危险。
- d) 在电动工具接通之前，拿掉所有调节钥匙或扳手。
遗留在电动工具旋转零件上的扳手或钥匙会导致人身伤害。
- e) 手不要伸展得太长。时刻注意立足点和身体平衡。
这样在意外情况下能很好地控制电动工具。
- f) 着装适当。不要穿宽松衣服或佩戴饰品。让衣服、手套和头发远离运动部件。
宽松衣服、佩饰或长发可能会卷入运动部件中。
- g) 如果提供了与排屑、集尘设备连接用的装置，要确保它们连接完好且使用得当。
使用这些装置可减少尘屑引起的危险。

4) 电动工具使用和注意事项

- a) 不要滥用电动工具，根据用途使用适当的电动工具。
选用适当设计的电动工具会使你工作更有效、更安全。
- b) 如果开关不能接通或关断工具电源，则不能使用该电动工具。
不能用开关来控制的电动工具是危险的且必须进行修理。
- c) 在进行任何调节、更换附件或贮存电动工具之前，必须从电源上拔掉插头和 / 或使电池盒与工具脱离。
这种防护性措施将减少工具意外起动的危险。

中文

- d) 将闲置不用的电动工具贮存在儿童所及范围之外，并且不要让不熟悉电动工具或对这些说明不了解的人操作电动工具。
电动工具在未经培训的用户手中是危险的。
- e) 保养电动工具。检查运动件是否调整到位或卡住，检查零件破损情况和影响电动工具运行的其他状况。如有损坏，电动工具应在使用前修理好。许多事故由维护不良的电动工具引发。
- f) 保持切削刀具锋利和清洁。
保养良好的有锋利切削刃的刀具不易卡住而且容易控制。
- g) 按照使用说明书，考虑作业条件和进行的作业来使用电动工具、附件和工具的刀头等。
将电动工具用于那些与其用途不符的操作可能会导致危险。

5) 电池式工具使用和注意事项

- a) 只用制造商规定的充电器充电。
将适用于某种电池盒的充电器用到其他电池盒时会发生着火危险。
- b) 只使用配有特制电池盒的电动工具。
使用其他电池盒会发生损坏和着火危险。
- c) 当电池盒不用时，将它远离其他金属物体，例如回形针、硬币、钥匙、钉子、螺钉或其他小金属物体，以防一端与另一端连接。
电池端部短路会引起燃烧或火灾。
- d) 在滥用条件下，液体会从电池中溅出；避免接触。如果无意间碰到了，用水冲洗。如果液体碰到了眼睛，还要寻求医疗帮助。
从电池中溅出的液体会发生腐蚀或燃烧。

6) 维修

- a) 将你的电动工具送交专业维修人员，使用同样的备件进行修理。
这样将确保所维修的电动工具的安全性。

注意！

不可让儿童和体弱人士靠近工作场所。

应将不使用的工具存放在儿童和体弱人士接触不到的地方。

所有圆锯的安全说明

危险！

- a) 让手始终远离锯割区域和锯片。你的另一只手始终握住辅助手柄或电动机机壳。
如果双手都握住圆锯，就不会被锯片伤害。
- b) 不得接触工件的下面。
护罩不能防止工件下方锯片的危险。
- c) 将锯割深度调至工件的厚度。
能看到在工件下露出的锯齿应不到一个齿高。

- d) 不得手持工件或将工件架在腿上进行锯割，应将工件夹紧在一个稳定的平台上。
适当支撑工件对减少人身伤害、锯片卡住或操作失控是至关重要的。
- e) 在锯割工具进行操作时有可能碰到暗线或自身电线的场合，须通过绝缘握持面来握住电动工具。
碰到“带电”电线也会使工具的裸露金属部分带电，从而使操作者触电。
- f) 当作劈锯时，始终使用劈锯护栏和直边导向器。
这样改善了锯割精度并减小了锯片卡住的几率。
- g) 始终使用尺寸和轴心形状（菱形或圆形）得当的锯片。
如果锯片与圆锯夹装部件不符将引起偏心运转而导致失控。
- h) 不得使用损坏的和尺寸不符的垫圈和螺栓。
为改善作业和安全运行，锯片垫圈及螺栓是为圆锯专门设计的。

对各种圆锯的进一步安全说明

回弹的原因和操作者防护：

- 回弹是当锯片受挤压、被卡住或偏离中心时的突然反作用，使圆锯不受控制地抬起并脱离工件冲向操作者。
- 当锯片受挤压或被收拢的切口紧紧卡住时，锯片堵转且电动机反作用力驱使整机朝操作者快速弹回。
- 如果锯片发生扭曲或偏离锯割面，锯片后边缘上的锯齿会挖入木材上表面从而引起锯片爬出切口并朝操作者回弹。

回弹是误用圆锯和/或不正确操作程序或条件导致的结果，采取以下适当预防措施可避免回弹。

- a) 双手紧握圆锯上的把手，双臂放置得能抵住回弹力。身体处于圆锯的任意一侧而不对准锯片。
回弹会导致圆锯的向后弹起，但如果采取了适当的防备措施，回弹力可以受操作者的控制。
- b) 当锯片卡住，或因任何原因导致的锯割中断时，释放开关扳机并握持圆锯在材料中不移动，直到锯片完全停止。不得在锯片处于运转或可能发生回弹情况下尝试将圆锯从工件中拿走或向后拉动圆锯。
调查并采取正确的措施以消除锯片卡住的原因。
- c) 当在工件中重新起动圆锯时，将锯片对准切口并检查锯齿是否插入材料。
如果锯片卡住了，工具重新起动时，锯片会爬出工件或从工件上回弹。
- d) 支撑大型板料以减少锯片受挤压和回弹的危害。
大型板料因自重向下垂，支撑物必须放置在板料下面的两侧，靠近切割线和板料边缘都要放置。
- e) 不得使用钝的或破损的锯片。
没有开锋的或安装不当的锯片会形成窄小的锯痕，从而导致剧烈摩擦、锯片卡住和回弹。

中文

- f) 锯割之前，锯割深度和倾角调节锁定钮必须旋紧和紧固。
如果锯割时锯片调节器发生移动，可能会引起锯片卡住和回弹。
- g) 当对现存墙体或其他盲区进行“插入式锯割”时要格外小心。
伸出锯片可能会锯割到引起回弹的物体。

带摆动式内护罩的圆锯的安全说明

- a) 每次使用前，检查下护罩闭合是否自如。如果下护罩不能迅速回复，则不得操作圆锯。不得将下护罩夹住或系绑在开启位置。
如果圆锯突然跌落，下护罩可能会弯曲变形，用回缩手柄抬起下护罩，确信在任何锯割角度和深度下护罩回缩自如，且不会触及锯片和任何其它零件。
- b) 检查下护罩弹簧的工作情况，如果护罩及弹簧不能正常工作，必须在使用前对其进行维修。
下护罩可能因零件损害、胶质沉积或废屑堆积而运动迟缓。
- c) 仅当特殊锯割，例如“插入式锯割”和“组合式锯割”，才应用手动方式抬起下护罩。用回缩手柄抬起下护罩，锯片刚一进入到锯割材料就必须释放下护罩。
对所有其他锯割作业，下护罩应自动回复。
- d) 在把圆锯放置在工作台或地上之前始终能看到下护罩是遮住锯片的。
未经防护的、有惯性的锯片引起圆锯后退，锯割到其行程上的物体，要考虑到开关释放后锯片停下来的时间。

使用电圆锯时的注意事项

- 1. 调整。在锯割之前，确认已调整锯割深度和倾斜角度。
- 2. 避免割到铁钉。在锯割前检查并拆下所有的铁钉。
- 3. 操作锯片时，将电线从锯割区域移开并固定住，以防在锯割作业时刮到工件上的电线。
作业时适当地用手部支撑和工件支撑，并将电线从作业区域移开。

警告！

适当支撑工件对减少人身伤害、锯片卡住或操作失控是至关重要的。常见的手部支撑锯片方法如图 1 所示。

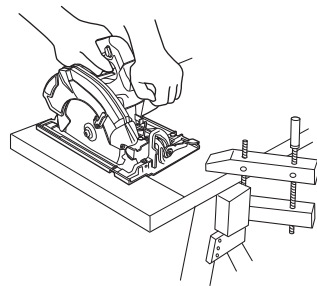

手部支撑、工件支撑和布线图示。

图 1

4. 将锯座的大部分放在工件有坚固支撑的部分，而非锯割后将会掉落的部分。例如，图 2 所示为锯割木板末端的方法，图 3 为错误方法。如果工件过于短小，请将其固定。请勿手握较短的部分！



图 2



图 3

5. 请勿用被虎钳颠倒夹住的电圆锯进行锯割。这种做法非常危险，会造成严重事故。（图 4）
6. 在完成锯割作业，放下工具前，务必确保下（可伸缩）护罩已关闭，刀刃已完全停止。

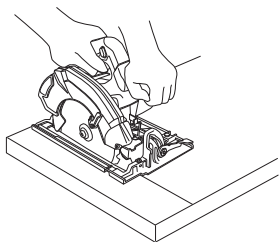

图 4

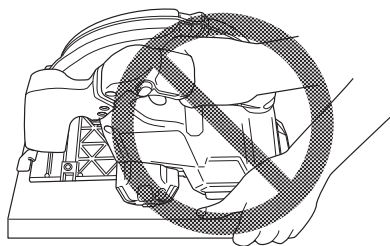
7. 请勿仅使用工具的鼓风机功能。（图 5）
8. 请按规定方式使用电动工具，切勿移作他用。请按使用说明书中记载的规定方式使用电动工具，切勿移作他用。

9. 请勿在锯片贴近身旁时运转锯片。
10. 请勿使用破损或无法正常运转的工具。如果工具无法正常操作，发出奇怪响声或发生破损，请立即停止使用，并联系 HiKOKI 授权服务中心进行维修。

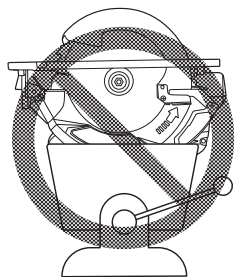

图 5

11. 请勿穿戴使用易卷起材料制成的手套，如棉布、毛线、布料或线等。
12. 请勿触碰移动的部件。请勿将手、手指或身体的其他部位靠近工具的移动部件。
13. 请勿在未安装护罩的情况下进行操作。请勿在没有护罩、安全装置，或作业顺序错误的情况下进行操作。如果需要取下护罩或安全装置进行维护或维修，请更换护罩或安全装置后再操作该工具。

中文

14. 请正确使用工具。
请勿将小型工具或附件强行用作重型工具。
请勿将工具用于其他目的，例如，请勿使用电圆锯来锯割树枝或木头。
15. 请正确操作工具。
请按照使用说明书中记载的内容操作工具。请勿掉落或扔掷工具。请勿让儿童、不熟悉操作步骤或未授权的人员操作该工具。
16. 符号定义。
V..... 伏特
---..... 直流电流
no..... 空载速度
---/min..... 每分钟转数或往复移动
Hz..... 赫兹
A..... 安培
17. 将所有螺钉、螺栓和盖子紧固在正确的位置。
将所有螺钉、螺栓和盖子安装牢靠。并定期检查其紧固状况。
18. 请勿在塑料外壳或手柄破裂的情况下使用电动工具。
如果工具外壳或手柄破裂，可能会导致触电。需修理后再使用。
19. 请务必将刀刃和附件牢固安装到工具上。
防止自己或他人受伤。刀刃、锯割工具和配件必须安全牢靠地安装到工具上。
20. 请小心操作电动工具。
如果电动工具无意间掉落或撞到坚硬的金属，则可能变形、破裂或损坏。
21. 请勿使用溶剂擦拭塑料部件。
汽油、稀释剂、四氯化碳和酒精等溶剂可能会造成塑料部件损坏或破裂。请勿使用上述溶剂进行擦拭。
请用沾有肥皂水的软布擦拭塑料部件，并将其完全晾干。
22. 请保持电机排气孔清洁。
请务必使该工具的电机排气孔保持清洁，确保空气可以自由流动。经常检查是否堆积灰尘。
23. 请勿使工具在无人值守的状态下运转。关闭电源。
请勿在工具完全停止前离开。
24. 请勿在操作后直接用手触摸刀刃。
25. 由于充电式电圆锯是电池供电的，因此请注意工具可能会随时开始运转。
26. 在较高的位置作业时，请确保下方没有人，并注意下方的情况。
27. 请勿强烈撞击或破坏开关面板。否则可能会导致故障。

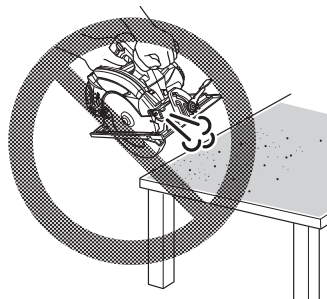
锂离子电池使用注意事项

为延长使用期限，锂离子电池备配停止输出的保护功能。
若是在使用本产品时发生下列 1 至 3 的情况，即使按下开关，马达也可能停止。这并非故障，而是启动保护功能的结果。

1. 在残留的电池电力即将耗尽时，马达会停止。
在这种情况下，请立即予以充电。
 2. 若工具超过负荷，马达亦可能停止。在这种情况下，请松开工具的开关，试着消除超过负荷的原因。之后您就可以再度使用。
 3. 若电池在过载工作情况下过热，电池电力可能会中止。
在这种情况下，请停止使用电池，让电池冷却。之后您就可以再度使用。
- 此外，请留心下列的警告及注意事项。

警告！

为防止发生电池漏电、发热、冒烟、爆炸及提前点燃，请确保留意下列事项。

1. 确保电池上没有堆积削屑及灰尘。
 - 在工作时确定削屑及灰尘没有掉落在电池上。
 - 确定所有工作时掉落在电动工具上的削屑和灰尘没有堆积在电池上。
 - 请勿将未使用的电池存放在曝露于削屑和灰尘的位置。
 - 在存放电池之前，请清除任何可能附着在上面的削屑和灰尘，并请切勿将它与金属零件（螺丝、钉子等）存放在一起。
2. 请勿以钉子等利器刺穿电池、以铁锤敲打、踩踏、丢掷电池，或将其剧烈撞击。
3. 切勿使用明显损坏或变形的电池。
4. 使用电池时请勿颠倒电极。
5. 请勿直接连接电源插座或汽车点烟器孔座。
6. 请依规定方式使用电池，切勿移作他用。
7. 如果已过了再充电时间，电池仍无法完成充电，请立即停止继续再充电。
8. 请勿将电池放置于高温或高压处，例如微波炉、烘干机或高压容器内。
9. 在发觉有渗漏或异味时，请勿接近远离火源。
10. 请勿在会产生强烈静电的地方使用。
11. 如有电池渗漏、异味、发热、褪色或变形，或在使用、充电或存放时出现任何异常，请立即将它从装备或电池充电器拆下，并停止使用。
12. 请勿浸泡电池或让任何液体流入电池内部。导电液体进入（如水），可能造成电池损坏，甚至可导致火灾或爆炸。将电池存放在阴凉、干燥的地方，远离易燃物品。必须避免将电池置于腐蚀性气体环境中。

注意！

1. 若电池渗漏出的液体进入您的眼睛，请勿搓揉眼睛，并以自来水等干净清水充分冲洗，立刻送医。
若不加以处理，液体可能会导致眼睛不适。
2. 若液体渗漏至您的皮肤或衣物，请立即以自来水等清水冲洗。
上述情况可能会使皮肤受到刺激。
3. 若初次使用电池时发现生锈、异味、过热、褪色、变形及 / 或其它异常情况时，请勿使用并将该电池退还给供货商或厂商。

中文

警告！

如果导电异物接触到锂离子电池的端子，电池可能短路，并导致火灾。

存放锂离子电池时，请务必遵循下列注意事项。

- 切勿在存放盒中放置导电的残片，钉子，以及导线，如铁线和铜线。
- 或者将电池装在电动工具中，或者在牢固按入电池盖并挡住通风孔后再存放，以防止短路。（参照图 6）



图 6

锂离子电池运输

当运输一个锂离子电池，请注意以下预防措施。

警告！

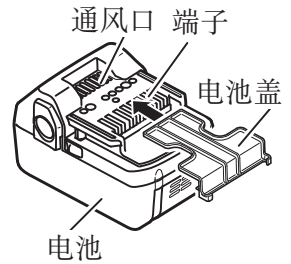
告知运输公司，包装内包含一个锂离子电池，告知该公司其功率输出并且要按照运输公司的指引安排运输。

- 功率输出超过 100Wh 的锂离子电池被视作危险物品运输分类并且需要特别申请程序。
- 对于境外运输，您必须遵守国际法以及输入国的规章和条例。
- 如果电动工具中装有 BSL36B18（另售），功率输出将超过 100 Wh，装置将被归类为危险物品。



图 7

符号

警告！

如下所示的符号用于本机。使用前请务必理解其含意。

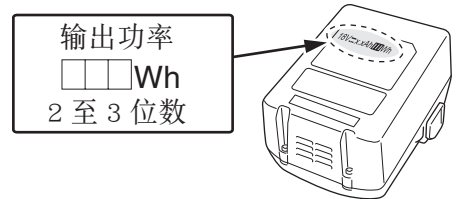
	为降低伤害风险，用户必须阅读使用说明书	n_0	空载转速
	直流电	/min	每分钟的振动次数
V	额定电压		警告

零件名称

1. 电动工具



图 8

2. 电池 (选购附件)

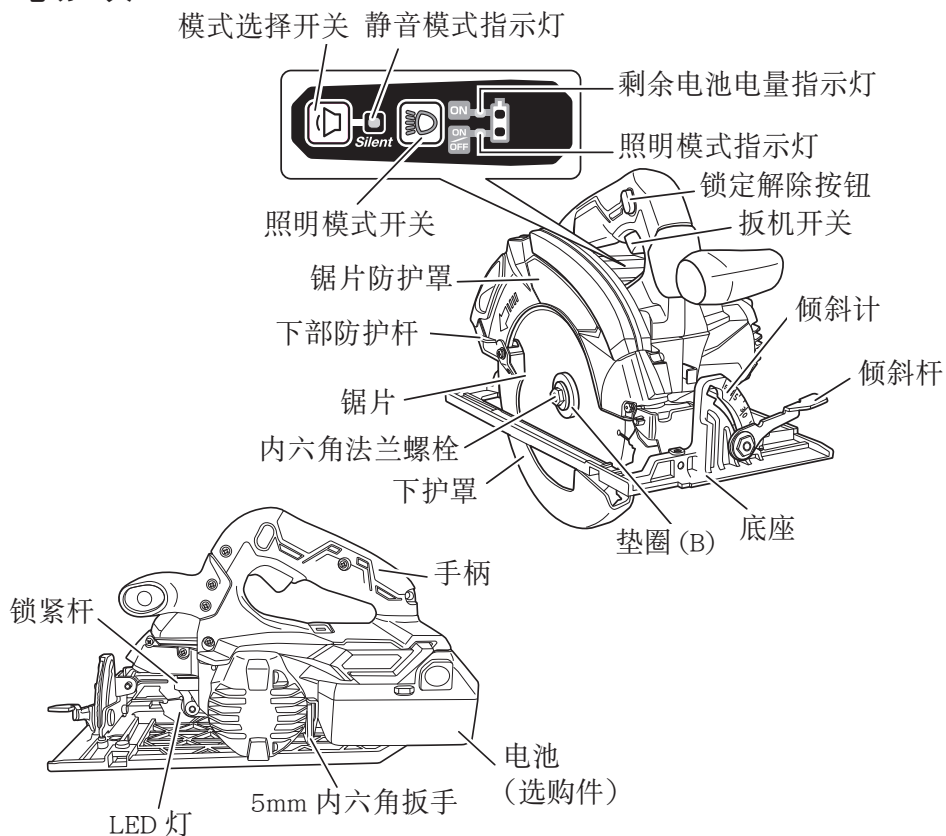
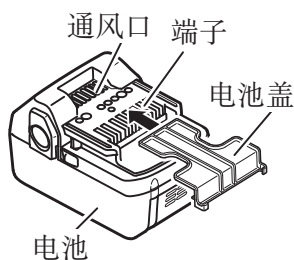

<BSL1850>

图 9

3. 电池充电器 (选购附件)

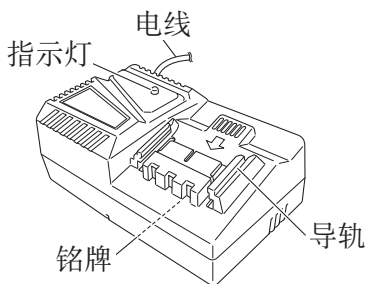

<UC18YFSL>

图 10

规格

电动工具

型式	C1807DA		
电压	18V		
空载转速	强力模式	3800/min	
	静音模式	2000/min	
能力	锯切深度	90度	64.5mm
		45度	69mm
重量	3.9kg (安装 BS1850)		

电子控制

- 软启动
- 过载保护

在操作过程中,如果电机过载,此保护功能可以断开电机电源,明显降低转速。过载保护功能被激活时,电机会停止。

在这种情况下,请松开工具的开关,试着消除过载的原因。

然后再重新使用。

- 过热保护

在操作过程中,如果电机过热,此保护功能可以断开电机电源,使电动工具停止运行。

过热保护功能被激活时,电机会停止。

在这种情况下,请松开工具的开关,冷却数分钟。

然后再重新使用。

- 转速切换功能 (强力模式 / 静音模式)
(强力模式 / 静音模式切换功能)

每按一下模式选择开关,都可改变操作模式。(图 11)

在静音模式下,电机的最大 RPM 降低,可以在减少噪音的情况下进行高效作业。

在静音模式下,静音模式指示灯亮起。

静音模式下的负载增加时,工具将自动切换到强力模式,并在负载减少时恢复至静音模式。

在电源模式下,即使负载降低,也不会对静音模式作出改变。

模式选择开关

静音模式指示灯



图 11



注

- 如要启用模式变更，请在安装电池后立即拉动开关。
- 请勿强烈撞击或破坏开关面板。否则可能会导致故障。

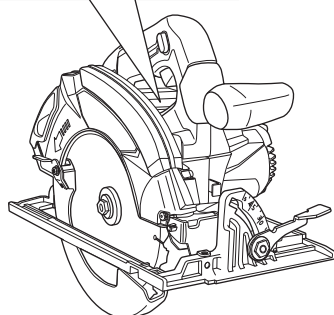
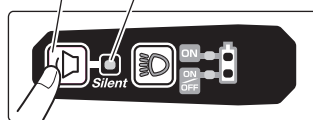
标准附件

除了主机（1 台）外，产品包中还包括表中所列的附件。

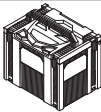
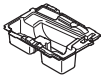
表 1

		C1807DA (NNP)
塑料盒		1
内托盘		1
六角条形扳手		1
集尘器装置		1

用途

锯割各种木材。

电池的拆卸 / 安装法

1. 电池的拆卸法

请先紧抓住把手，然后再推压电池插销以拆下电池（参照图 12）。

注意！

切勿使电池短路。

2. 电池的安装法

插入电池时请注意极性（参照图 12）。



图 12

充电

使用电动工具之前，按下述方法将电池进行充电。

1. 将充电器的电源线连接到插座。

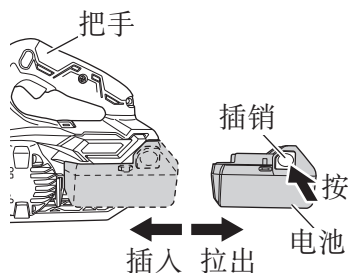
将充电器插头连接到插座时，指示灯闪烁红色（间隔为 1 秒）。

2. 将电池插入充电器。

如图 13 所示，将电池紧紧地插入充电器。

3. 充电

将电池插入充电器后，将开始充电，指示灯会持续点亮呈红色。

电池完全充电后，指示灯将闪烁呈红色（以 1 秒的间隔）（参照如表 2）。

● 指示灯显示

根据充电器或充电式电池的情况，指示灯的显示如表 2 所示。



图 13

表 2

指示灯的显示			
指示灯 (红色)	充电前	闪烁 点亮0.5秒钟，不点亮0.5秒钟 (熄灭 0.5秒钟)	
	充电时	点亮 连续点亮	
	充电完成	闪烁 点亮0.5秒钟，不点亮0.5秒钟 (熄灭0.5秒钟)	
	过热而等待	闪烁 点亮1秒钟，不点亮0.5秒钟 (熄灭0.5秒钟)	电池过热。无法 充电（电池冷却后 开始进行充电）。
	无法充电	闪动 点亮0.1秒钟，不点亮0.1秒钟 (熄灭0.1秒钟)	电池或充电器有 问题。

- 电池温度和充电时间相关资料。
温度和充电时间如表 3 所示

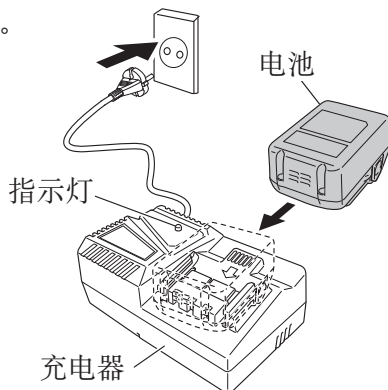
表 3

电池		充电器	UC18YFSL
充电电压		V	14.4—18
重量		kg	0.5
电池可充电温度			0°C—50°C
电池容量的大致充电时间 (20°C 下)			
1.5Ah	分钟		22
2.0Ah	分钟		30
2.5Ah	分钟		35
3.0Ah	分钟		45
4.0Ah	分钟		60
5.0Ah	分钟		75
6.0Ah	分钟		90
8.0Ah	分钟		120
电池数			4—10

注：

充电时间可能根据环境温度和电压而有变化。

注意！

连续使用时，电池充电器温度将提升，因此会导致出现故障。完成充电后，下次充电前，请让电池充电器休息15分钟。

4. 从电源插座拔下充电器的电源线。
5. 握紧充电器并取出电池。

注：

充电后，先将电池从充电器中取出，然后妥善保存。

关于新电池的放电。

新电池内部的化学物质未被激活或电池长时间不使用时，初次或第二次使用时需要将其放电至较低电量。这只是暂时现象，将电池充电2—3次即可恢复为充电所需的正常时间。

较长时间保持电池性能的方法

- (1) 在电池电力完全耗尽之前进行充电。

感到电动工具的能力变弱时，请停止使用并给电池充电。若您继续使用电动工具并耗尽电力，电池可能会损坏或其使用寿命缩短。

中文

(2) 避免在高温环境中充电。

使用后可充电电池的温度将迅速升高。若使用后立即对这种电池进行充电，其内部化学物质会劣化，电池使用寿命将缩短。请稍等片刻，待电池冷却后再进行充电。

注意！

○ 如果电池长时间放置在阳光直接照射的地方或者刚刚使用完毕时，电池会变热。如果此时对电池充电，充电器上的指示灯会点亮1秒钟，不点亮0.5秒钟（熄灭0.5秒钟）。

在此情况下，先让电池冷却下来，然后再充电。

○ 指示灯闪动时（以0.2秒钟的间隔），请检查并取出充电器电池接口处的任何异物。若无异物，则可能电池或充电器发生故障。请带去经授权的维修中心检查。

○ 由于内置的微型计算机需要大约3秒钟来确认使用充电器充电的电池已取出，所以请等待至少3秒钟后再将电池重新插入继续充电。如果电池在3秒内重新插入，电池可能无法正常充电。

○ 如果指示灯未以红色闪烁（每秒一次），但充电池电源线已连接至电源，表明充电器的保护电路可能已激活。

拔下电源线或插座，然后等待30秒左右再次连接。如果指示灯仍未以红色闪烁（每秒一次），请将充电器送还至HiKOKI授权服务中心。

作业之前

注意！

为避免发生严重事故，请确保开关处于关断位置，并取出电池。

1. 检查工作区域环境。

检查工作区域，确保没有杂物且不杂乱。

请勿使无关人员靠近。确保照明和通风充足。

2. 安装锯片（图 14）

警告！

如果使用随附的六角扳手以外的工具对内六角法兰螺栓进行操作，将导致旋扭过紧或无法充分拧紧，造成人员受伤。

(1) 将主轴、螺栓以及垫圈周围堆积的切屑完全清除干净。

(2) 安装锯片时，垫圈(A)和(B)的凹入侧必须和锯片侧一致。将锯片安装到主轴上，最后固定垫圈(B)（参见图 14）



图 14

- (3) 为确保锯片转动方向正确，锯片上的箭头方向必须与锯盖上的箭头方向一致。
- (4) 用手指尽量将固定锯片的内六角螺栓拧紧。然后压下锁紧杆，锁住主轴，并拧紧螺栓。
- (5) 确保锁紧杆仍在原来的位置。

注意！

安装锯片后，请再次确认锁定按钮已牢固固定在指定位置。

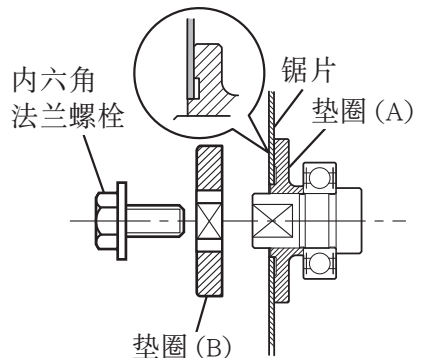
3. 拆下锯片

注意！

请勿在使用后立即触摸锯片。金属仍处于高温状态，易灼伤皮肤。

- (1) 将锯割量调到最大，将电圆锯如图 15 所示放置。
- (2) 压住锁紧杆，锁住主轴，然后用 5mm 内六角扳手拆下内六角法兰螺栓和垫圈 (B)。
- (3) 握住下部防护杆以使下部防护罩完全缩回到锯盖内，拆下锯片 (图 16)。

5mm 内六角扳手



图 15



图 16

4. 检查下护罩的性能

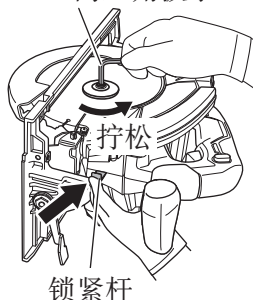
警告！

请务必确保下护罩未被固定。此外，请检查其是否可以顺滑移动。如果锯片露出，可能会造成人员受伤。

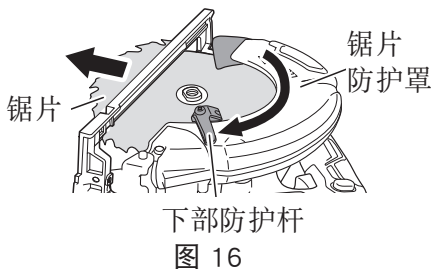
下护罩（参见第 11 页的图 8）可保护作业人员的身体不接触到锯片。请务必确保防护罩能顺滑地覆盖住锯片。如果下护罩无法顺畅移动，请在维修后使用。

此种情况下，请联系您购买电圆锯的店铺或 HiKOKI 授权服务中心进行维修。

5. 检查制动器是否正常

此款电圆锯配备了电力制动器，可以在松开开关时发挥作用。使用电圆锯前，请确保电力制动器功能正常。如功能不正常，请将工具带到 HiKOKI 授权服务中心进行维修。

中文

6. 制备木质工作台（图 17）

锯片将露出锯木下面，因此锯割时应将锯木放在工作台上。若用方木块作为工作台，则应选择平坦地面，以保持稳定。使用不平稳的工作台，则可能会导致危险。



图 17

注意！

为避免可能发生的事故，请将锯割后的锯木剩余部分拴住放妥。

7. 检查电池的插入

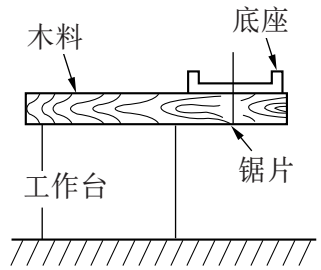
警告！

若电源开关接通，则插入电池后，电动工具将出其不意地立刻转动，从而导致严重事故。

注意！

请确保电池装入正确的位置，直至发出喀嗒声，否则可能会使电池突然掉落，导致使用者或周围人员受伤。

使用前调整电圆锯

注意！

请先取下电池再进行调整。

1. 调整锯割深度

警告！

如果控制杆(A)松动，将造成人员受伤。请在调整后将其紧固。

如要调整锯割深度，请用一只手握住底座，另一只手松动控制杆(A)，上下移动机身以达到指定的锯割深度。调整至指定的锯割深度后，牢牢紧固控制杆(A)。



图 18

2. 调整倾斜角度

警告！

如果倾斜杆松动，将造成人员受伤。请在调整后将其紧固。

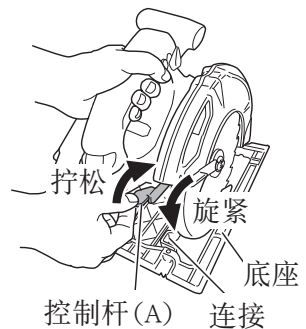
可以倾斜锯片，使之与底座间形成 0° 到最大 55° 的角度。

如图 19 所示，松开斜尺上的倾斜杆，锯片与底座间将形成 45° 角。

如果所用的倾斜角超过 45° ，如图 20 所示将倾斜杆外移，锯片与底座间可形成最大 55° 角。

请务必确保在作出适当的调整后，牢牢紧固倾斜杆。



图 19



图 20

3. 调整导轨 (纵剖薄板) (图 21、22) 选购件
将翼形螺栓 (B) 和锁簧安装到底座上。将导轨插入底座并左右移动，调整锯割位置。拧紧翼形螺栓 (B)，并固定导轨。将导轨安装在主体的左侧或右侧均可。

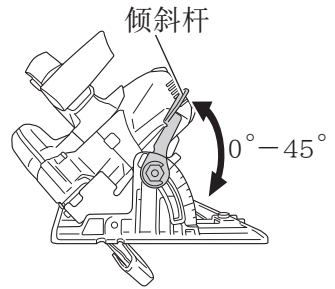

图 21

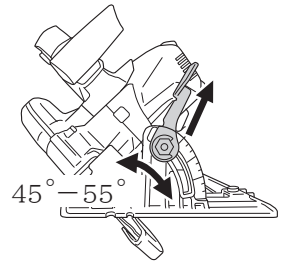

图 22

(纵剖薄板)

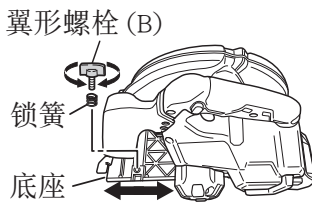
4. 使用集尘器装置

如要使用真空集尘器收集锯屑，请使用 M4 螺丝将吸水管连接到与主机相连的集尘器装置。(图 23)。

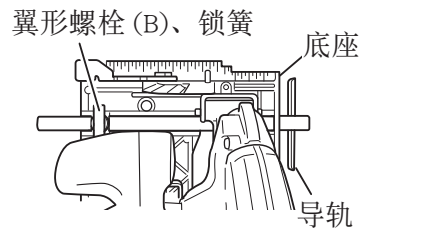

图 23

操作

警告！

- 请勿触碰移动的部件。
- 请勿在锯片朝上或朝侧面的情况下操作电圆锯。
- 请勿固定锁定解除按钮。此外，携带电圆锯时，让手指远离扳机开关。否则可能会在不经意间按下机身，导致意外事故。
- 仅在锯割作业时亮灯。如果在其他情况下亮起，机身开关将在不经意间开启，导致意外事故。
- 请勿使用砂轮。
- 请勿使用产品铭牌规定的锯片直径以外的锯片。
- 移动刀刃进行切锯时，请勿将电圆锯从工件上移开。

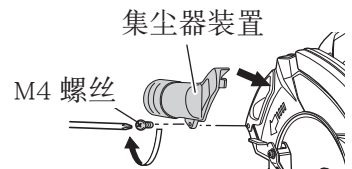
注意！

- 完成作业后，取出电池。
- 请勿直视 LED 灯光。持续或直接暴露在 LED 灯光下可能会导致视力受损。
- 为延长使用期限，锂离子电池配备了停止输出的保护功能。因此，若工具超过负荷，电机也会停止。然而，这并非故障问题，而是保护功能起作用的结果。在这种情况下，请松开工具的开关，试着消除超过负荷的原因。
- 在使用前，请检查锁定解除按钮是否能平滑移动。

注：

请勿锁住电机。如果电机锁住，请立即断开开关。如果电机已被锁住一段时间，可能会使电机或电池烧损。

1. 检查锯片是否紧固

在工厂组装时，会紧固锯片以便于立即使用，但为慎重起见，请再次检查。将螺栓顺时针旋转，可以将其拧紧。使用随附的 5mm 内六角扳手进行检查。有关详细信息，请参见 16 页记载的 [作业之前]。

2. 检查控制杆是否紧固

如果调整锯割深度的控制杆（第 18 页的图 18）松动，可能会造成人员受伤。请确保已牢牢拧紧。

3. 开关操作（图 24）

（扳机开关和指示灯开关）

手柄侧面设有“锁定解除按钮”以保证安全操作机器。



图 24

如果在依照箭头方向按下“锁定解除按钮”的情况下拉动“扳机开关”，则可以打开总开关。

开关处于开启（ON）位置后，只要扳动扳机开关，即使松开锁定解除按钮，锯片也会继续作业。此外，LED 灯将在常亮模式和 SW 互锁模式下持续亮灯。

4. 关于模式选择功能

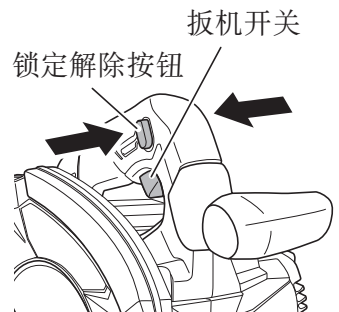
按下模式选择开关，操作模式将会变化。

选择静音模式时，静音模式指示灯亮起。

在静音模式下，电机的最大 RPM 降低，可以在减少噪音的情况下进行高效作业。

如果在电机以静音模式运行时负载增加，将自动切换到强力模式。

此外，如果负载再次降低，将自动恢复至静音模式。

在电源模式下，即使负载降低，也不会对静音模式作出改变。

模式	空载速度
强力	3800/min
静音	2000/min

注：

○ 只有在安装电池和拉动开关后，模式才会改变。



○ 即使开关处于 ON/OFF 位置，也可保持当前模式，或取下 / 插入电池。

5. 关于剩余电池电量指示灯

可以拉动开关，使剩余电池电量指示灯亮红灯，以查看剩余电量。（图 24）

释放开关 10 秒后，指示灯将变为照明模式指示灯（绿色）。表 4 显示的是剩余电池电量指示灯的状态和电池剩余电量。

表 4

指示灯状态	电池剩余电量
	电池剩余电量充足。
	电池剩余一半电量。
	电池剩余电量即将耗尽。 请尽快对电池进行充电。

环境温度和电池特性不同，则所显示的电池剩余电量也会有些许不同，以上内容仅供参考。

6. LED 灯的使用方法

按下照明模式开关，LED 灯模式的变化如 表 5 所示。指示绿色灯。(图 25) 请经常关灯以防消耗电池电量。

表 5

	常亮模式	SW 互锁模式	省电模式
面板显示			
状态	常亮模式 (2 分钟后 关闭)	仅在软件 运行时亮 灯 (松开 开关约 10 秒钟后 自动熄灭)	常灭



图 25

注意！

○ 请不要直视灯光，避免眼睛直接受灯光照射。

如果眼睛持续受灯光照射，会伤害眼睛。

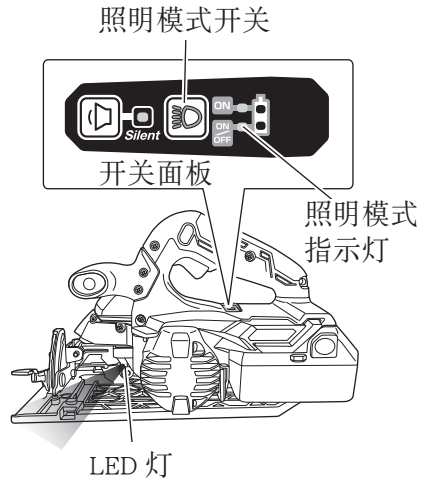
○ 用软布仔细擦拭附着在 LED 灯镜片上的灰尘或污垢，小心不要划伤镜片。如果划伤 LED 灯的镜片，可能会导致亮度减弱。

注：

如果忘记关闭 LED 灯，LED 灯将自动熄灭 2 分钟以防消耗电池电量。

7. 固定导轨 (另售)

将翼形螺栓 (B) 和锁簧安装到底座上。将导轨插入底座并左右移动，调整锯割位置。拧紧翼形螺栓 (B)，并固定导轨。将导轨安装在主体的左侧或右侧均可。



图 26



图 27

警告！

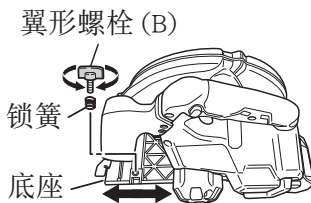
在使用导轨时，避免斜向锯割，这可能会导致锯割材料夹在锯片和导轨之间。否则可能造成人员受伤。

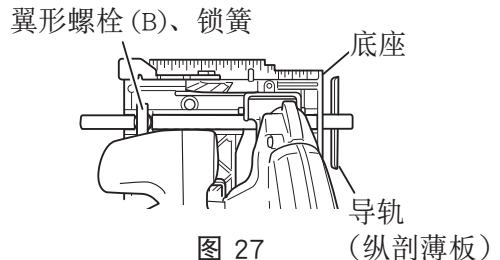

图 28

8. 锯割步骤

注意！

- 重新检查锯片是否已牢固夹紧。
- 确认调整槽深的控制杆和倾斜角度。

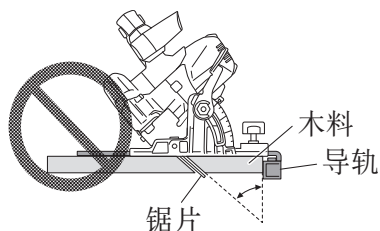
(1) 将底座置于材料上，然后将记号线和锯片对准底座前面的凹槽（图 29）。

(2) 底座无倾斜角度时，使用凹槽右侧（图 29、图 30）。

如果底座有倾斜角度（45 度），使用凹槽左侧（图 29、图 31）。



图 29 < 俯视图 >



图 30

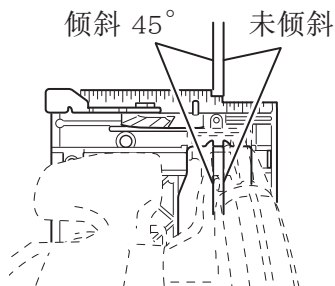

图 31

注：

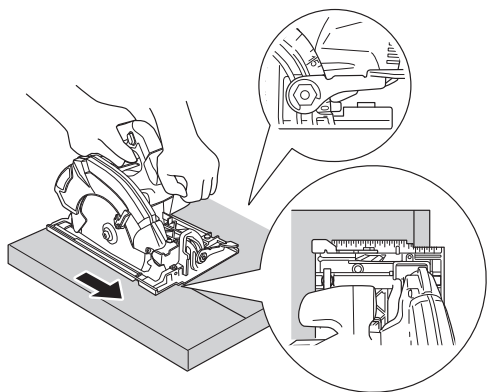
以 45 度倾斜角使用电锯时，可根据斜板上的标记和底座倾斜计上的 [45] 进行操作（图 32）。

另外，如果需要以精确的角度使用电锯，请用量角器等进行调整。

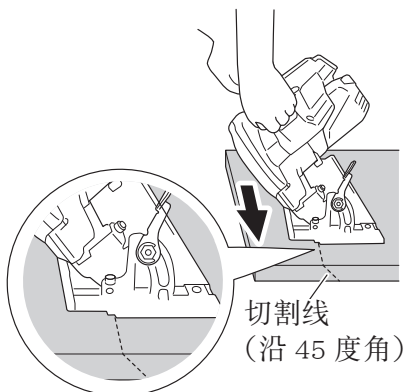
- (3) 锯片在开始进行锯切材料之前，务必先将开关切换至开启（ON）的位置。扳动扳机时即可将开关切换至开启（ON），而松开扳机时便可将开关切换至关闭（OFF）。以定速笔直移动电圆锯可进行最佳锯割。

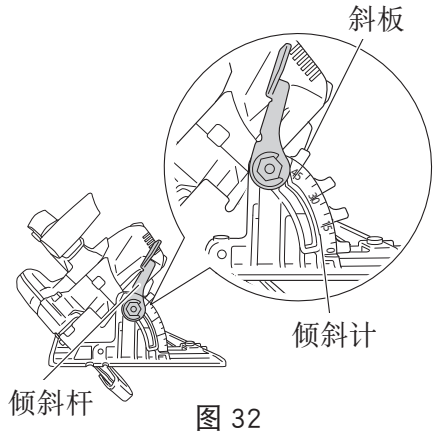

注意！

- 在开始锯割之前，先确认锯片以达到全速转速。
- 作业完成后，将电池从机身取下。
- 为避免刀刃尖端过热或锯片损坏，请勿在锯割时弯曲切割，或对锯片过于用力。请确保刀刃平稳地向前移动。
- 如果用储存的备用电池来更换电池，电圆锯连续作业，将造成电机过热。因此，如果外壳过热，请将电锯搁置一段时间。
- 如果底座从要锯割的材料上翘起，请勿锯割。 否则将导致电机锁住。

9. 凹槽剪切

警告！

- 为了避免发生严重事故，务必将开关置于关闭（OFF）位置，并在调整前取出电池。
- 请勿将下护罩固定或卡在较高的位置。

- (1) 用线在各面清楚地标记出锯割部分。（参见图 33）。
- (2) 根据要锯割的材料调整深度。
- (3) 如图 33 所示，一直向后推动控制杆，使刀刃露出。
- (4) 将电锯向前倾斜，并将凹槽（第 23 页的图 29）对准预先标记的基准线。
- (5) 松开控制杆。下护罩与工件表面接触时，将处于适当位置以便于在开始锯割时自由打开。
- (6) 使电锯处于适当位置，确保刀刃未接触工件表面，拉动扳机。
- (7) 电锯达到全速模式后，逐渐放下电锯后部，直至底座接触工作台表面。



图 33

- (8) 沿切割线将电锯移动至边角。
- (9) 松开扳机，待刀刃完全停止，再从工件将刀刃取下。
- 请勿在刀刃移动时向后拉动电锯，否则可能导致反弹。
- (10) 用曲线锯或手锯将边角锯割干净。
- (11) 新开始锯割时，重复上述操作。

LED 灯警示信号 (图 34)

该产品设计出具有保护该工具以及电池的功能。如表 6 所示，拉动开关后，如果在操作过程中触发任意保护功能，LED 灯将闪烁。当启动任何保护功能，立即将您的手指从开关上移开并按照正确步骤所描述的指引进行操作。

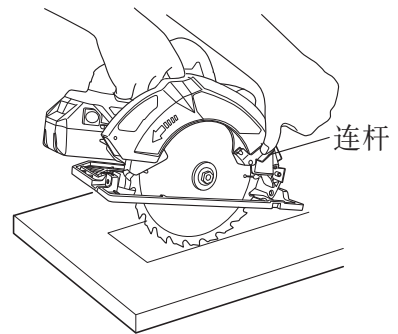

图 34

表 6

保护功能	LED 灯显示	正确步骤
负重过度保护	开启 0.1 秒 / 关闭 0.1 秒 ■ ■ ■ ■ ■ ■ ■ ■ ■ ■ ■ ■ ■ ■ ■ ■	解除负担过重原因。
温度保护	开启 0.5 秒 / 关闭 0.5 秒 ■■■■ ■■■■ ■■■■	让该工具和电池得到充分冷却。

维护和检查

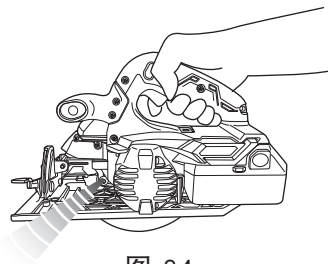
警告！

检查或维护前，请务必关闭开关并取出电池。

1. 检查锯片

如果继续使用较钝或损坏的刀刃，将降低锯割效率，并可能导致电机过载。查出锯片有磨损时，请立即更换新的刀刃。

注意！

若使用较钝的刀刃作业，则切锯时产生的反作用力会增加。请避免使用未经维修的较钝刀刃。

2. 检查螺钉

松动的螺钉会导致危险。请经常检查螺钉是否已拧紧。

注意！

使用螺钉松动的电动工具会导致危险。

中文

3. 电动机的维护

电动机绕线此电动工具的重要部件。应避免损伤，注意不要被油液或水沾湿。

使用 50 小时后，请用空气枪或其他工具向电动机的通风孔内吹入干燥的空气，仔细清洁电动机（图 35）。

电动机中灰尘或杂质颗粒堆积可能会导致故障。

4. 检查和维护下护罩

确保下护罩能平滑移动。

如果发生故障，请立即修理下护罩。

清洁和维护下护罩时，请使用空气枪或其他工具吹送干燥的空气，吹净下护罩与齿轮罩之间的部位，以及下护罩的转动部位（图 35）。

可以有效去除碎屑或其他杂质颗粒。

下护罩周围堆积碎屑或其他杂质颗粒，可能会导致故障或损伤。

警告！

如要防止灰尘吸入或眼睛刺痛，请在使用空气枪或其他工具清洁下护罩、通风孔或产品的其他部分时，仔细佩戴好护目镜和防尘口罩。

5. 清洁锯片防护罩内部

定期检查并清洁锯片防护罩，确保未堆积碎屑或其他杂质颗粒。

6. 调整底座和锯片以保持垂直（图 36）

底座和锯片之间的角度已被调整为 90 度，但是，这一垂直角度可能会由于某些原因而改变，请按以下方式调整。

7. 检查端子（工具和电池）

确保端子上没有堆积削屑和灰尘。

在操作前、操作时和操作后需要时常检查。

注意！

请清除端子上的削屑或灰尘。

否则可能导致故障。



图 35



图 36

8. 清理外部

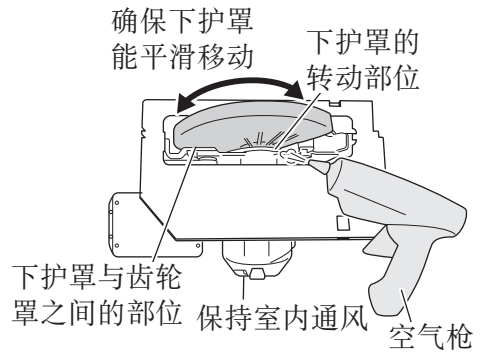
冲击起子机沾污时，用干软布或沾肥皂水的布擦拭。切勿使用氯溶液、汽油或稀释剂，以免塑胶部分溶化。

9. 润滑

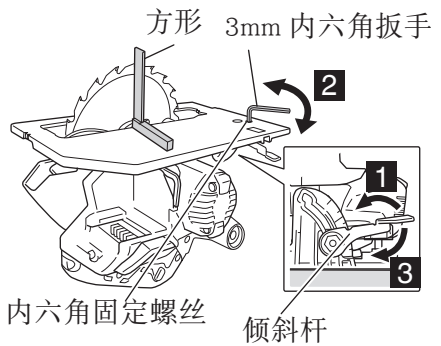
考虑到该工具在正常作业条件下的预期使用寿命，轴承已经过优质润滑油的充分润滑。因此，无需进一步润滑。

10. 电力耗尽的电池的处理方法

警告！

请勿将电力耗尽的电池丢弃。如果焚烧电池，可能会引起爆炸。该电池可回收利用。根据各国家和地区的法令法规，将电力耗尽的电池丢弃到城市垃圾中属于违法行为。请向当地的固体废弃物负责人员咨询具体回收事宜或妥善的处理方法。

11. 收藏

冲击起子机应收藏于温度低于 40°C 和小孩拿不到的地方。

注：

存放锂离子电池

在存放前请确保电池已完全充电。

电池在低电量的状态下长时间存放（3 个月或更长），可能会导致电池性能劣化，使用时间明显减少或无法进行充电。

但是，即使是使用时间明显减少的电池，通过反复充电和使用 2 ~ 5 次，有时也可恢复使用时间。

若反复充电和使用后电池的使用时间仍非常短，请认作为电池已达到了使用寿命并更换新的电池。

注意！

在操作和维修电动工具时，必须遵守贵国制定的安全的有关规则和标准。

关于 HiKOKI 牌无线电动工具的重要通知：

请确保始终使用我们指定的正版电池。如果使用我们指定以外的电池，或对电池进行拆卸和改动（例如拆卸和更换电池组件或其他内部部件），那么我们无法保证我们无线电动工具的安全性和使用性能。

故障排除

如果工具操作不正常，请使用下表中的检查步骤。如果未能解决问题，请向经销商或 HIKOKI 公司授权服务中心咨询。

1. 电动工具

现象	可能的原因	解决办法
工具无法运行	没有剩余电池电量	为电池充电
	插入电池时，扳机开关为按下状态。	安全功能被激活。 一旦松开扳机开关，然后重新拉动，工具将开始运转。
工具突然停止	工具过度负重	避免因负载过重而引发的问题。
	电池过热。	让电池冷却。
	按下扳机开关 5 分钟或更久。	这种情况不属于故障。 电机已自动停止以防止工具发生故障。
无法倾斜	未松开倾斜杆。	松开倾斜杆，然后试着倾斜。 进行必要的调整操作后，紧固松动的部分。
锯割效果不佳	锯片磨损或缺齿。	更换新的锯片。
	螺栓松动。	拧紧螺栓。
	锯片装反。	按正确的方向安装锯片。
无法拉动开关	前向 / 反向选择器按钮位于中间位置	将按钮牢牢按压在适当位置以旋转至理想的方向。
无法将锯屑清除干净	锯屑堆积在锯片防护罩内。	清除锯片防护罩内部的锯屑。
机器上的剩余电池电量指示灯与多电压电池不匹配。	—	参见电池上的指示灯。

选择附件

根据特定作业选择适合的附件。
有关详细信息请联系 HiKOKI 授权服务中心。

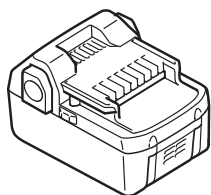

BSL18..
电池

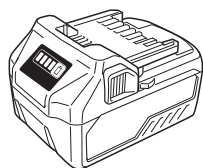

BSL36..18
电池

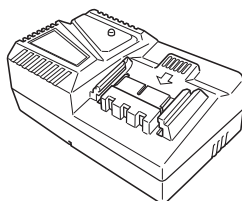

UC18YFSL
(14.4V-18V)
充电器

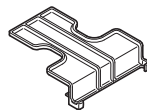

产品编号: 329897
电池盖



321639

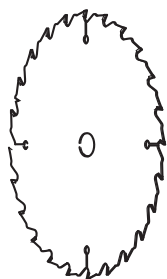

330888



333555



338917

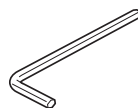

944459

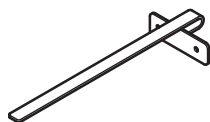

302691



377954

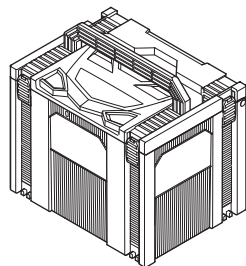

337528

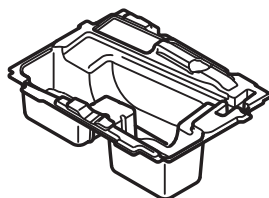

373646

CONTENTS

GENERAL POWER TOOL SAFETY WARNINGS	30
SAFETY INSTRUCTIONS FOR ALL SAWS	33
FURTHER SAFETY INSTRUCTIONS FOR ALL SAWS	33
SAFETY INSTRUCTIONS FOR SAWS WITH INNER PENDULUM GUARD ...	34
PRECAUTIONS ON USING CIRCULAR SAW	35
CAUTION ON LITHIUM-ION BATTERY	38
REGARDING LITHIUM-ION BATTERY TRANSPORTATION	39
SYMBOLS	40
NAME OF PARTS.....	40
SPECIFICATIONS	41
STANDARD ACCESSORIES	42
APPLICATIONS.....	42
BATTERY REMOVAL / INSTALLATION	43
CHARGING	43
PRIOR TO OPERATION.....	46
ADJUSTING THE SAW PRIOR TO USE	48
OPERATION.....	50
LED LIGHT WARNING SIGNALS.....	56
MAINTENANCE AND INSPECTION	56
TROUBLESHOOTING.....	59
SELECTING ACCESSORIES.....	60

GENERAL POWER TOOL SAFETY WARNINGS

WARNING

Read all safety warnings and all instructions.

Failure to follow the warnings and instructions may result in electric shock, fire and/or serious injury.

Save all warnings and instructions for future reference.

The term “power tool” in the warnings refers to your mains-operated (corded) power tool or battery-operated (cordless) power tool.

- 1) **Work area safety**
 - a) **Keep work area clean and well lit.**
Cluttered or dark areas invite accidents.
 - b) **Do not operate power tools in explosive atmospheres, such as in the presence of flammable liquids, gases or dust.**
Power tools create sparks which may ignite the dust or fumes.
 - c) **Keep children and bystanders away while operating a power tool.**
Distractions can cause you to lose control.

2) **Electrical safety**

- a) **Power tool plugs must match the outlet.**
Never modify the plug in any way.
Do not use any adapter plugs with earthed (grounded) power tools.
Unmodified plugs and matching outlets will reduce risk of electric shock.
- b) **Avoid body contact with earthed or grounded surfaces, such as pipes, radiators, ranges and refrigerators.**
There is an increased risk of electric shock if your body is earthed or grounded.
- c) **Do not expose power tools to rain or wet conditions.**
Water entering a power tool will increase the risk of electric shock.
- d) **Do not abuse the cord. Never use the cord for carrying, pulling or unplugging the power tool.**
Keep cord away from heat, oil, sharp edges or moving parts.
Damaged or entangled cords increase the risk of electric shock.
- e) **When operating a power tool outdoors, use an extension cord suitable for outdoor use.**
Use of a cord suitable for outdoor use reduces the risk of electric shock.
- f) **If operating a power tool in a damp location is unavoidable, use a residual current device (RCD) protected supply.**
Use of an RCD reduces the risk of electric shock.

3) **Personal safety**

- a) **Stay alert, watch what you are doing and use common sense when operating a power tool.**
Do not use a power tool while you are tired or under the influence of drugs, alcohol or medication.
A moment of inattention while operating power tools may result in serious personal injury.
- b) **Use personal protective equipment. Always wear eye protection.**
Protective equipment such as dust mask, non-skid safety shoes, hard hat, or hearing protection used for appropriate conditions will reduce personal injuries.
- c) **Prevent unintentional starting. Ensure the switch is in the off position before connecting to power source and/or battery pack, picking up or carrying the tool.**
Carrying power tools with your finger on the switch or energising power tools that have the switch on invites accidents.
- d) **Remove any adjusting key or wrench before turning the power tool on.**
A wrench or a key left attached to a rotating part of the power tool may result in personal injury.
- e) **Do not overreach. Keep proper footing and balance at all times.**
This enables better control of the power tool in unexpected situations.
- f) **Dress properly. Do not wear loose clothing or jewellery. Keep your hair, clothing and gloves away from moving parts.**
Loose clothes, jewellery or long hair can be caught in moving parts.
- g) **If devices are provided for the connection of dust extraction and collection facilities, ensure these are connected and properly used.**
Use of dust collection can reduce dust-related hazards.

English

4) Power tool use and care

- a) **Do not force the power tool. Use the correct power tool for your application.**
The correct power tool will do the job better and safer at the rate for which it was designed.
- b) **Do not use the power tool if the switch does not turn it on and off.**
Any power tool that cannot be controlled with the switch is dangerous and must be repaired.
- c) **Disconnect the plug from the power source and/or the battery pack from the power tool before making any adjustments, changing accessories, or storing power tools.**
Such preventive safety measures reduce the risk of starting the power tool accidentally.
- d) **Store idle power tools out of the reach of children and do not allow persons unfamiliar with the power tool or these instructions to operate the power tool.**
Power tools are dangerous in the hands of untrained users.
- e) **Maintain power tools. Check for misalignment or binding of moving parts, breakage of parts and any other condition that may affect the power tool's operation.**
If damaged, have the power tool repaired before use.
Many accidents are caused by poorly maintained power tools.
- f) **Keep cutting tools sharp and clean.**
Properly maintained cutting tools with sharp cutting edges are less likely to bind and are easier to control.
- g) **Use the power tool, accessories and tool bits etc. in accordance with these instructions, taking into account the working conditions and the work to be performed.**
Use of the power tool for operations different from those intended could result in a hazardous situation.

5) Battery tool use and care

- a) **Recharge only with the charger specified by the manufacturer.**
A charger that is suitable for one type of battery pack may create a risk of fire when used with another battery pack.
- b) **Use power tools only with specifically designated battery packs.**
Use of any other battery packs may create a risk of injury and fire.
- c) **When battery pack is not in use, keep it away from other metal objects, like paper clips, coins, keys, nails, screws or other small metal objects, that can make a connection from one terminal to another.**
Shorting the battery terminals together may cause burns or a fire.
- d) **Under abusive conditions, liquid may be ejected from the battery; avoid contact. If contact accidentally occurs, flush with water. If liquid contacts eyes, additionally seek medical help.**
Liquid ejected from the battery may cause irritation or burns.

6) Service

- a) Have your power tool serviced by a qualified repair person using only identical replacement parts.

This will ensure that the safety of the power tool is maintained.

CAUTION

Keep children and infirm persons away.

When not in use, tools should be stored out of reach of children and infirm persons.

SAFETY INSTRUCTIONS FOR ALL SAWS**DANGER**

- a) **Keep hands away from cutting area and the blade. Keep your second hand on auxiliary handle, or motor housing.**
If both hands are holding the saw, they cannot be cut by the blade.
- b) **Do not reach underneath the workpiece.**
The guard cannot protect you from the blade below the workpiece.
- c) **Adjust the cutting depth to the thickness of the workpiece.**
Less than a full tooth of the blade teeth should be visible below the workpiece.
- d) **Never hold piece being cut in your hands or across your leg. Secure the workpiece to a stable platform.**
It is important to support the work properly to minimize body exposure, blade binding, or loss of control.
- e) **Hold power tool by insulated gripping surfaces when performing an operation where the cutting tool may contact hidden wiring or its own cord.**
Contact with a "live" wire will also make exposed metal parts of the power tool "live" and shock the operator.
- f) **When ripping always use a rip fence or straight edge guide.**
This improves the accuracy of cut and reduces the chance of blade binding.
- g) **Always use blades with correct size and shape (diamond versus round) of arbour holes.**
Blades that do not match the mounting hardware of the saw will run eccentrically, causing loss of control.
- h) **Never use damaged or incorrect blade washers or bolt.**
The blade washers and bolt were specially designed for your saw, for optimum performance and safety of operation.

FURTHER SAFETY INSTRUCTIONS FOR ALL SAWS

Causes and operator prevention of kickback:

- kickback is a sudden reaction to a pinched, bound or misaligned saw blade, causing an uncontrolled saw to lift up and out of the workpiece toward the operator;
- when the blade is pinched or bound tightly by the kerf closing down, the blade stalls and the motor reaction drives the unit rapidly back toward the operator;

English

- if the blade becomes twisted or misaligned in the cut, the teeth at the back edge of the blade can dig into the top surface of the wood causing the blade to climb out of the kerf and jump back toward the operator.

Kickback is the result of saw misuse and/or incorrect operating procedures or conditions and can be avoided by taking proper precautions as given below.

- Maintain a firm grip with both hands on the saw and position your arms to resist kickback forces.**
Position your body either side of the blade, but not in line with the blade.
Kickback could cause the saw to jump backwards, but kickback forces can be controlled by the operator, if proper precautions are taken.
- When blade is binding, or when interrupting a cut for any reason, release the trigger and hold the saw motionless in the material until the blade comes to a complete stop.**
Never attempt to remove the saw from the work or pull the saw backward while the blade is in motion or kickback may occur.
Investigate and take corrective actions to eliminate the cause of blade binding.
- When restarting a saw in the workpiece, centre the saw blade in the kerf and check that saw teeth are not engaged into the material.**
If saw blade is binding, it may walk up or kickback from the workpiece as the saw is restarted.
- Support large panels to minimize the risk of blade pinching and kickback.**
Large panels tend to sag under their own weight. Supports must be placed under the panel on both sides, near the line of cut and near the edge of the panel.
- Do not use dull or damaged blades.**
Unsharpened or improperly set blades produce narrow kerf causing excessive friction, blade binding and kickback.
- Blade depth and bevel adjusting locking levers must be tight and secure before making cut.**
If blade adjustment shifts while cutting, it may cause binding and kickback.
- Use extra caution when making a “plunge cut” into existing walls or other blind areas.**
The protruding blade may cut objects that can cause kickback.

SAFETY INSTRUCTIONS FOR SAWS WITH INNER PENDULUM GUARD

- Check lower guard for proper closing before each use. Do not operate the saw if lower guard does not move freely and close instantly. Never clamp or tie the lower guard into the open position.**
If saw is accidentally dropped, lower guard may be bent. Raise the lower guard with the retracting handle and make sure it moves freely and does not touch the blade or any other part, in all angles and depth of cut.

- b) **Check the operation of the lower guard spring. If the guard and the spring are not operating properly, they must be serviced before use.**

Lower guard may operate sluggishly due to damaged parts, gummy deposits, or build-up of debris.

- c) **Lower guard should be retracted manually only for special cuts such as “plunge cuts” and “compound cuts”. Raise lower guard by retracting handle and as soon as blade enters the material, the lower guard must be released.**

For all other sawing, the lower guard should operate automatically.

- d) **Always observe that the lower guard is covering the blade before placing saw down on bench or floor.**

An unprotected, coasting blade will cause the saw to walk backwards, cutting whatever is in its path.

Be aware of the time it takes for the blade to stop after switch is released.

PRECAUTIONS ON USING CIRCULAR SAW

1. **Adjustments. Before cutting be sure depth and bevel adjustments are tight.**
2. **Avoid cutting nails. Inspect for and remove all nails from work piece before cutting.**
3. **When operating the saw, keep the cord away from the cutting area and position it so that it will not be caught on the workpiece during the cutting operation. Operate with proper hand support, proper workpiece support, and supply cord routing away from the work area.**

WARNING

It is important to support the work piece properly and to hold the saw firmly to prevent loss of control which could cause personal injury. Fig. 1 illustrates typical hand support of the saw.

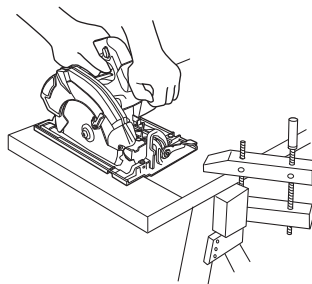

A TYPICAL ILLUSTRATION OF PROPER HAND SUPPORT WORKPIECE SUPPORT, AND SUPPLY CORD ROUTING.

Fig. 1

English

4. Place the wider portion of the saw base on that part of the work piece which is solidly supported, not on the section that will fall off when the cut is made. As examples, Fig. 2 illustrates the RIGHT way to cut off the end of board, and Fig. 3 the WRONG way. If the work piece is short or small, clamp it down. **DON'T TRY TO HOLD SHORT PLACES BY HAND!**

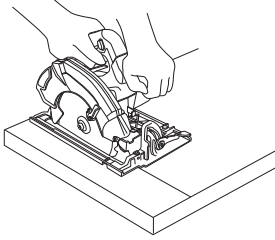

Fig. 2

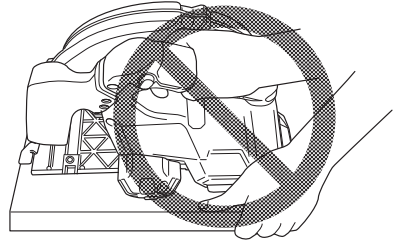

Fig. 3

5. Never attempt to saw with the circular saw held upside down in a vise. This is extremely dangerous and can lead to serious accidents. (Fig. 4)

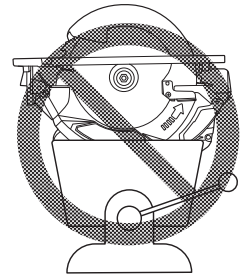

Fig. 4

6. Before setting the tool down after completing a cut, be sure that the lower (telescoping) guard has closed and the blade has come to a complete stop.

7. Do not use the tool with only the blower function. (Fig. 5)

8. Never use a power tool for applications other than those specified.

Never use a power tool for applications other than those specified in the Instruction Manual.

9. Do not run the saw while carrying it at your side.

10. Never use a tool which is defective or operating abnormally.

If the tool appears to be operating unusually, making strange noises, or otherwise appears defective, stop using it immediately and arrange for repairs by a HiKOKI authorized service center.

11. Never wear gloves made of material liable to roll up such as cotton, wool, cloth or string, etc.

12. Never touch moving parts.

Never place your hands, fingers or other body parts near the tool's moving parts.

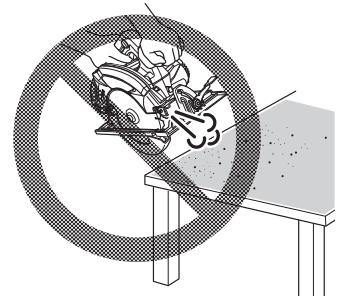

Fig. 5

13. **Never operate without all guards in place.**
Never operate this tool without all guards or safety features in place and in proper working order. If maintenance or servicing requires the removal of a guard or safety feature, be sure to replace the guard or safety feature before resuming operation of the tool.
14. **Use right tool.**
Don't force small tool or attachment to do the job of a heavy-duty tool.
Don't use tool for purpose not intended—for example— don't use circular saw for cutting tree limbs or logs.
15. **Handle tool correctly.**
Operate the tool according to the instructions provided herein. Do not drop or throw the tool. Never allow the tool to be operated by children, individuals unfamiliar with its operation or unauthorized personnel.
16. **Definitions for symbols.**
V.....volts
===.....direct current
no.....no load speed
---/min.....revolutions or reciprocation per minute
Hz.....hertz
A.....amperes
17. **Keep all screws, bolts and covers tightly in place.**
Keep all screws, bolts, and plates tightly mounted. Check their condition periodically.
18. **Do not use power tools if the plastic housing or handle is cracked.**
Cracks in the tool's housing or handle can lead to electric shock. Such tools should not be used until repaired.
19. **Blades and accessories must be securely mounted to the tool.**
Prevent potential injuries to yourself or others. Blades, cutting implements and accessories which have been mounted to the tool should be secure and tight.
20. **Carefully handle power tools.**
Should a power tool be dropped or struck against hard materials inadvertently, it may be deformed, cracked, or damaged.
21. **Do not wipe plastic parts with solvent.**
Solvents such as gasoline, thinner benzine, carbon tetrachloride, and alcohol may damage and crack plastic parts. Do not wipe them with such solvents.
Wipe plastic parts with a soft cloth lightly dampened with soapy water and dried thoroughly.
22. **Keep motor air vent clean.**
The tool's motor air vent must be kept clean so that air can freely flow at all times. Check for dust build-up frequently.
23. **NEVER leave tool running unattended. Turn power off.**
Don't leave tool until it comes to a complete stop.
24. **NEVER touch the blade with bare hands after operation.**
25. **Because the cordless circular saw operates by battery power, be aware of the fact that it can begin to operate at any time.**

English

26. When working at elevated locations, clear the area of other people and aware of conditions below you.
27. Do not give a strong shock to the switch panel or break it. It may lead to a trouble.

CAUTION ON LITHIUM-ION BATTERY

To extend the lifetime, the lithium-ion battery equips with the protection function to stop the output.

In the cases of 1 to 3 described below, when using this product, even if you are pulling the switch, the motor may stop. This is not the trouble but the result of protection function.

1. When the battery power remaining runs out, the motor stops.
In such case, charge it up immediately.
2. If the tool is overloaded, the motor may stop. In this case, release the switch of tool and eliminate causes of overloading. After that, you can use it again.
3. If the battery is overheated under overload work, the battery power may stop. In this case, stop using the battery and let the battery cool. After that, you can use it again.

Furthermore, please heed the following warning and caution.

WARNING

In order to prevent any battery leakage, heat generation, smoke emission, explosion and ignition beforehand, please be sure to heed the following precautions.

1. Make sure that swarf and dust do not collect on the battery.
 - During work make sure that swarf and dust do not fall on the battery.
 - Make sure that any swarf and dust falling on the power tool during work do not collect on the battery.
 - Do not store an unused battery in a location exposed to swarf and dust.
 - Before storing a battery, remove any swarf and dust that may adhere to it and do not store it together with metal parts (screws, nails, etc.).
2. Do not pierce battery with a sharp object such as a nail, strike with a hammer, step on, throw or subject the battery to severe physical shock.
3. Do not use an apparently damaged or deformed battery.
4. Do not use the battery in reverse polarity.
5. Do not connect directly to an electrical outlets or car cigarette lighter sockets.
6. Do not use the battery for a purpose other than those specified.
7. If the battery charging fails to complete even when a specified recharging time has elapsed, immediately stop further recharging.
8. Do not put or subject the battery to high temperatures or high pressure such as into a microwave oven, dryer, or high pressure container.
9. Keep away from fire immediately when leakage or foul odor are detected.
10. Do not use in a location where strong static electricity generates.
11. If there is battery leakage, foul odor, heat generated, discolored or deformed, or in any way appears abnormal during use, recharging or storage, immediately remove it from the equipment or battery charger, and stop use.

- Do not immerse the battery or allow any fluids to flow inside. Conductive liquid ingress, such as water, can cause damage resulting in fire or explosion. Store your battery in a cool, dry place, away from combustible and flammable items. Corrosive gas atmospheres must be avoided.

CAUTION

- If liquid leaking from the battery gets into your eyes, do not rub your eyes and wash them well with fresh clean water such as tap water and contact a doctor immediately. If left untreated, the liquid may cause eye-problems.
- If liquid leaks onto your skin or clothes, wash well with clean water such as tap water immediately.
There is a possibility that this can cause skin irritation.
- If you find rust, foul odor, overheating, discolor, deformation, and/or other irregularities when using the battery for the first time, do not use and return it to your supplier or vendor.

WARNING

If a conductive foreign matter enters in the terminal of lithium ion battery, the battery may be shorted, causing fire. When storing the lithium ion battery, obey surely the rules of following contents.

- Do not place conductive debris, nail and wires such as iron wire and copper wire in the storage case.
- Either install the battery in the power tool or store by securely pressing into the battery cover until the ventilation holes are concealed to prevent short-circuits (See Fig. 6).

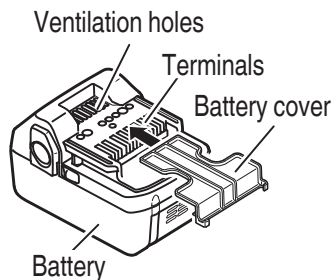

Fig. 6

REGARDING LITHIUM-ION BATTERY TRANSPORTATION

When transporting a lithium-ion battery, please observe the following precautions.

WARNING

Notify the transporting company that a package contains a lithium-ion battery, inform the company of its power output and follow the instructions of the transportation company when arranging transport.

- Lithium-ion batteries that exceed a power output of 100 Wh are considered to be in the freight classification of Dangerous Goods and will require special application procedures.
- For transportation abroad, you must comply with international law and the rules and regulations of the destination country.
- If the BSL36B18 (sold separately) is installed in the power tool, the power output will exceed 100 Wh and the unit will be classified as Dangerous Goods for freight classification.

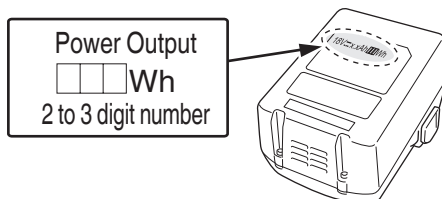





Fig. 7

SYMBOLS

WARNING

The following show symbols used for the machine. Be sure that you understand their meaning before use.

	To reduce the risk of injury, user must read instruction manual.	n_0	No-load speed
	Direct current	/min	Oscillation per minute
V	Rated voltage		Warning

NAME OF PARTS

1. POWER TOOL

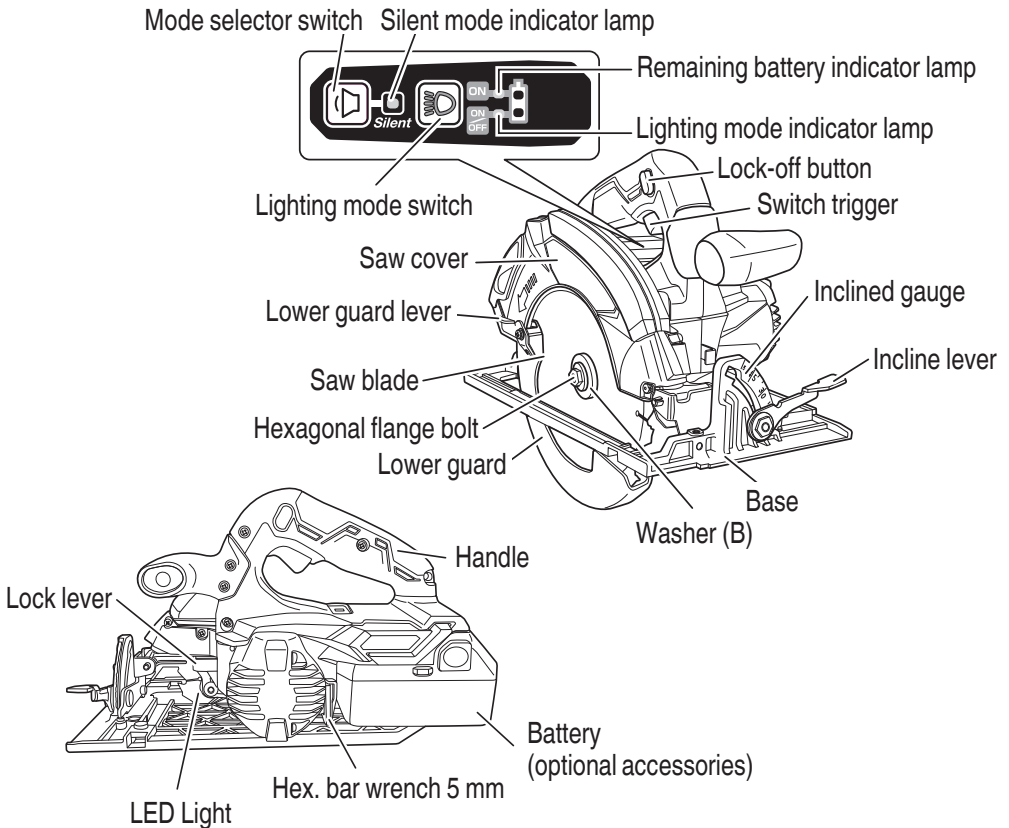

Fig. 8

2. Battery (optional accessory)

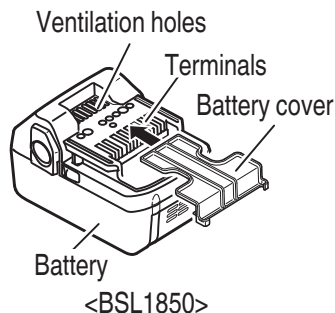

Fig. 9

3. Battery Charger (optional accessory)

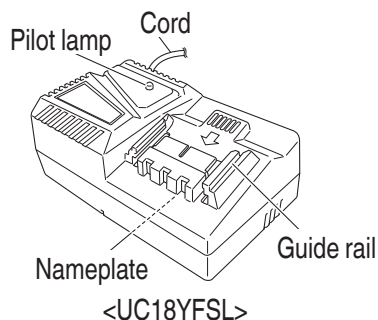

Fig. 10

SPECIFICATIONS

POWER TOOL

Model			C1807DA
Voltage			18 V
No-load speed	Power mode		3800 /min
	Silent mode		2000 /min
Capacity	Cutting depth	90°	64.5 mm
		45°	69 mm
Weight			3.9 kg (BSL1850 attached)

Electronic control

- Soft-start
- Overload protection
This protection feature cuts off the power to the motor in the event of overloading of motor or a conspicuous reduction in rotational speed during operation.
When the overload protection feature has been activated, the motor may stop.
In this case, release the tool switch and eliminate causes of overloading.
After that you can use it again.
- Overheat protection
This protection feature cuts off the power to the motor and stops the power tool in the event of overheating of motor during operation.
When the overheat protection feature has been activated, the motor may stop.
In this case, release the tool switch and cool it down in a few minutes.
After that you can use it again.

English

- Rotation speed changeover function (Power mode / Silent mode)

(Power mode / Silent mode switch function)

Each press of the Mode Selector Switch changes the operating mode. (Fig. 11)

Silent mode reduces maximum motor RPM enabling efficient work with less noise.

The Silent Mode Indicator Lamp lights in Silent mode.

When the load increases during Silent mode, the tool will automatically switch to Power mode and revert back to Silent mode when the load decreases.

In Power mode, no change is made to Silent mode even when the load decreases.

Mode selector switch
Silent mode indicator lamp

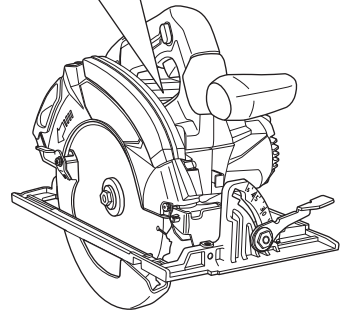
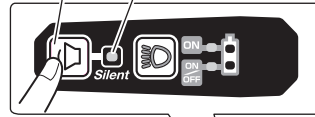

Fig. 11



NOTE

- To enable mode changes, pull the switch once after installing the battery.
- Do not give a strong shock to the switch panel or break it. It may lead to a trouble.

STANDARD ACCESSORIES

In addition to the main unit (1 unit), the package contains the accessories listed in the below.

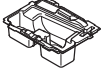
Table 1

		C1807DA (NNP)
Plastic case		1
Inner tray		1
Hex. bar wrench		1
Dust collector		1

APPLICATIONS

Cutting various types of wood.

BATTERY REMOVAL/INSTALLATION

1. Battery removal
Hold the handle tightly and push the battery latches to remove the battery (see Fig. 12).

CAUTION

Never short-circuit the battery.

2. Battery installation
Insert the battery while observing its polarities (see Fig. 12).

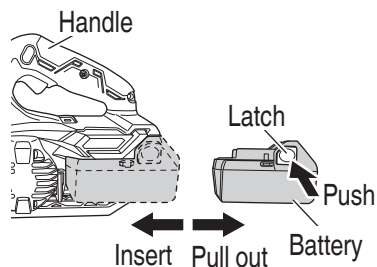

Fig. 12

CHARGING

Before using the power tool, charge the battery as follows.

1. Connect the charger's power cord to the receptacle.
When connecting the plug of the charger to a receptacle, the pilot lamp will blink in red (At 1- second intervals).
2. Insert the battery into the charger.
Firmly insert the battery into the charger as shown in Fig. 13.
3. Charging
When inserting a battery in the charger, charging will commence and the pilot lamp will light continuously in red.
When the battery becomes fully recharged, the pilot lamp will blink in red. (At 1-second intervals)
(See Table 2 on page 44)

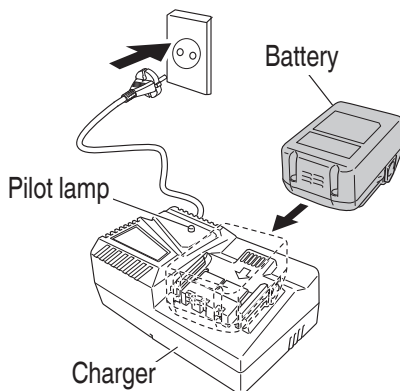







Fig. 13

English

- Pilot lamp indication

The indications of the pilot lamp will be as shown in **Table 2**, according to the condition of the charger or the rechargeable battery.

Table 2

Indications of the pilot lamp			
Pilot lamp (red)	Before charging	Blinks	Lights for 0.5 seconds. Does not light for 0.5 seconds. (off for 0.5 seconds) 
	While charging	Lights	Lights continuously 
	Charging complete	Blinks	Lights for 0.5 seconds. Does not light for 0.5 seconds. (off for 0.5 seconds) 
	Overheat standby	Blinks	Lights for 1 second. Does not light for 0.5 seconds. (off for 0.5 seconds) 
	Charging impossible	Flickers	Lights for 0.1 seconds. Does not light for 0.1 seconds. (off for 0.1 seconds) 
			Battery overheated. Unable to charge. (Charging will commence when battery cools)
			Malfunction in the battery or the charger

- Regarding the temperatures and charging time of the battery.

The temperatures and charging time will become as shown in **Table 3**.

Table 3

Battery	Charger	UC18YFSL
Charging voltage	V	14.4–18
Weight	kg	0.5
Temperatures at which the battery can be recharged		0°C–50°C
Charging time for battery capacity, approx. (At 20°C)		
1.5 Ah	min	22
2.0 Ah	min	30
2.5 Ah	min	35
3.0 Ah	min	45
4.0 Ah	min	60
5.0 Ah	min	75
6.0 Ah	min	90
8.0 Ah	min	120
Number of battery cells		4–10

NOTE

The recharging time may vary according to temperature and power source voltage.

CAUTION

When the battery charger has been continuously used, the battery charger will be heated, thus constituting the cause of the failures. Once the charging has been completed, give 15 minutes rest until the next charging.

4. Disconnect the charger's power cord from the receptacle.
5. Hold the charger firmly and pull out the battery.

NOTE

Be sure to pull out the battery from the charger after use, and then keep it.

Regarding electric discharge in case of new batteries, etc.

As the internal chemical substance of new batteries and batteries that have not been used for an extended period is not activated, the electric discharge might be low when using them the first and second time. This is a temporary phenomenon, and normal time required for recharging will be restored by recharging the batteries 2-3 times.

How to make the batteries perform longer.

- (1) Recharge the batteries before they become completely exhausted.
When you feel that the power of the tool becomes weaker, stop using the tool and recharge its battery. If you continue to use the tool and exhaust the electric current, the battery may be damaged and its life will become shorter.
- (2) Avoid recharging at high temperatures.
A rechargeable battery will be hot immediately after use. If such a battery is recharged immediately after use, its internal chemical substance will deteriorate, and the battery life will be shortened. Leave the battery and recharge it after it has cooled for a while.

CAUTION

- If the battery is charged while it is heated because it has been left for a long time in a location subject to direct sunlight or because the battery has just been used, the pilot lamp of the charger lights for 1 second, does not light for 0.5 seconds (off for 0.5 seconds). In such a case, first let the battery cool, then start charging.
- When the pilot lamp flickers (at 0.2-second intervals), check for and take out any foreign objects in the charger's battery connector. If there are no foreign objects, it is probable that the battery or charger is malfunctioning. Take it to your authorized Service Center.
- Since the built-in micro computer takes about 3 seconds to confirm that the battery being charged with charger is taken out, wait for a minimum of 3 seconds before reinserting it to continue charging. If the battery is reinserted within 3 seconds, the battery may not be properly charged.
- If the pilot lamp does not blink in red (every second) even though the charger cord is connected to the power, it indicates that the protection circuit of the charger may be activated.

Remove the cord or plug from the power and then connect it again after 30 seconds or so. If this does not cause the pilot lamp to blink in red (every second), please take the charger to the HiKOKI Authorized Service Center.

PRIOR TO OPERATION

CAUTION

To avoid serious accident, ensure the switch is in the OFF position, and pull out the battery.

1. Check the work area environment
Check the work area to make sure that it is clear of debris and clutter.
Clear the area of unnecessary personnel. Ensure that lighting and ventilation is adequate.
2. Mounting the Saw Blade (Fig. 14)

WARNING

If the hexagonal flange bolt is worked using other tools than the provided hex. wrench, excessive tightening and insufficient tightening may take place, resulting in injury.

- (1) Thoroughly remove any sawdust which has accumulated on the spindle, bolt and washers.
- (2) For mounting saw blade, the concave sides of both washers (A) and (B) must be fitted to the saw blade sides. Mount the saw blade on the spindle, and finally affix washer (B) (See Fig. 14)
- (3) To assure proper rotation direction of the saw blade, the arrow direction on the saw blade must coincide with the arrow direction on the blade cover.
- (4) Using the fingers, tighten the hexagonal bolt retaining the saw blade as much as possible. Then depress the lock lever, lock the spindle, and thoroughly tighten the bolt.
- (5) Confirm that the lock lever is in the original position.

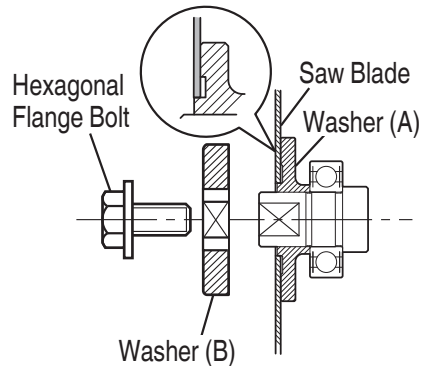

Fig. 14

CAUTION

After mounting the saw blade, reconfirm that the lock button is firmly secured in the prescribed position.

3. Dismounting the saw blade

CAUTION

Never touch the saw blade immediately after use. The metal is hot and can easily burn your skin.

- (1) Set the cutting volume at maximum, and place the Circular Saw as shown in **Fig. 15**.
- (2) Depress the lock lever, lock the spindle, and remove the hexagonal flange bolt and washer (B) with the hex. bar wrench 5 mm.
- (3) While holding the lower guard lever to keep the lower guard fully retracted into the saw cover, remove the saw blade (**Fig. 16**).

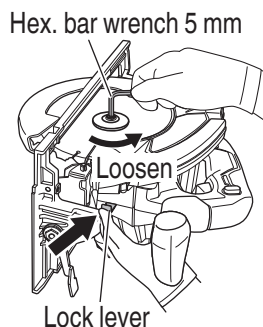
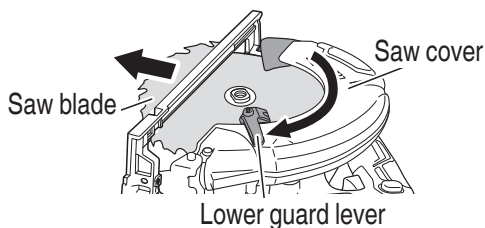
**Fig. 15****Fig. 16**

4. Check performance of lower guard

WARNING

Make absolutely sure that the lower guard is not fixed. Also, check and see if it can move smoothly. If the saw blade is kept exposed, injury can result.

The lower guard (refer to **Fig. 8 on page 40**) serves to protect your body from coming into contact with the saw blade. Make absolutely certain that the cover smoothly performs to cover the saw blade. If the lower guard should not move smoothly, never use it without repairing it.

In such a case, get in touch with the store where you bought the circular saw or the HIKOKI AUTHORIZED SERVICE CENTER for necessary repair.

5. Check for proper operation of the brake

This circular saw features an electric brake that functions when the switch is released. Before using the circular saw, ensure that the electric brake functions properly. If it does not, bring the tool to a HIKOKI AUTHORIZED SERVICE CENTER.

English

6. Prepare a wooden work bench (**Fig. 17**)
Since the saw blade will extend beyond the lower surface of the lumber, place the lumber on a work bench when cutting. If a square block is utilized as a work bench, select level ground to ensure it is properly stabilized. An unstable work bench will result in hazardous operation.

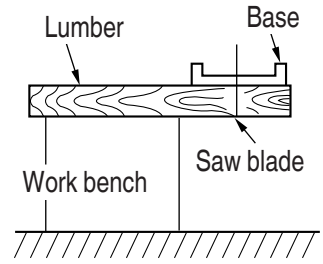

Fig. 17

CAUTION

To avoid possible accident, always ensure that the portion of lumber remaining after cutting is securely anchored or held in position.

7. Check battery insertion

WARNING

If the battery is inserted while the power switch is in the ON position, the power tool will start operating immediately, inviting serious accident.

CAUTION

Until the battery locks in place with a little click, if not, it may accidentally fall out of the tool causing injury to you or someone around you.

ADJUSTING THE SAW PRIOR TO USE

CAUTION

Pull out battery before doing any adjusting.

1. Adjusting the cutting depth

WARNING

If the lever (A) is loose, injury can result. Tighten it securely after adjustment.

To adjust cutting depth, loosen the lever (A) and, while holding the base with one hand, move the main body up and down to obtain the prescribed cutting depth. After adjusting to the prescribed cutting depth, tighten the lever (A) securely.

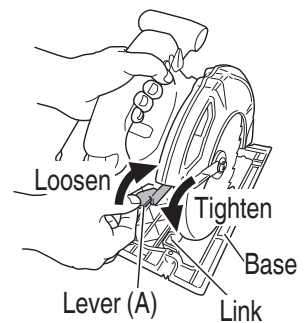

Fig. 18

2. Adjusting the angle of inclination

WARNING

If the incline lever is loose, injury can result. Tighten it securely after adjustment.

You can incline saw blade from 0° to a maximum angle of 55° in relation to the base.

As shown in **Fig. 19** by loosening the incline lever on the bevel scale, the saw blade may be inclined to an angle of 45° in relation to the base.

If you use inclination angle of over 45°, as shown in **Fig. 20** move the incline lever to outside, the saw blade may be inclined to a maximum angle of 55° in relation to the base. Always ensure that the incline lever is thoroughly tightened after making the desired adjustment.

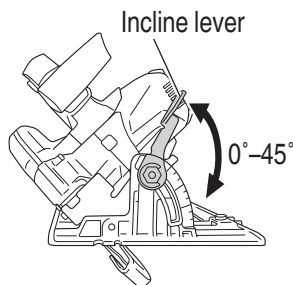

Fig. 19

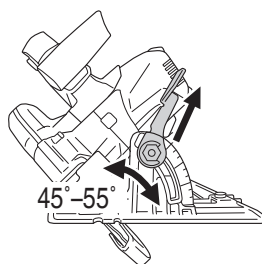

Fig. 20

3. Regulating the guide (Rip fence) (**Fig. 21, 22**)
..... Optional Accessory

Install the wing bolt (B) and lock spring on the base. Insert the guide into the base, move it left and right and adjust the cutting position. Tighten the wing bolt (B) and fix the guide. The guide can be installed either from the left or the right side of the main body.

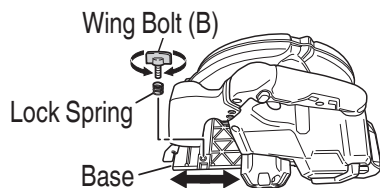

Fig. 21

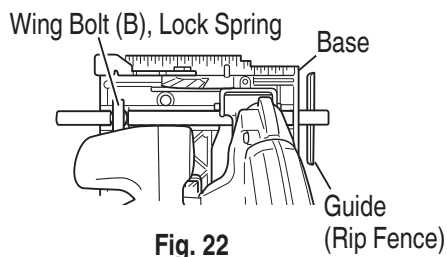

Fig. 22

4. Using the dust collector

To use the vacuum cleaner to gather up saw dust, attach the suction hose to the dust collector which is attached to the main unit by M4 screw. (**Fig. 23**).

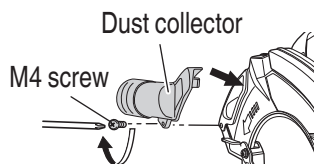

Fig. 23

OPERATION

WARNING

- Never touch the moving parts.
- Never operate the circular saw with the saw blade turned upward or to the side.
- Do not fix and secure the lock-off button. Besides, keep your finger off the switch trigger when the circular saw is being carried around. Otherwise, the main body switch can be inadvertently turned ON, resulting in unexpected accidents.
- Keep the light ON during cutting operation only. If it is lit ON in other cases, the main body switch can be inadvertently turned ON, resulting in unexpected accidents.
- Do not use any abrasive wheels.
- Use only blade diameter specified on the product nameplate.
- Don't remove circular saw from work piece during a cut while the saw blade is moving.

CAUTION

- Pull out the battery after completing operation.
- Do not look directly into the light from the LED light. Continuous and direct exposure to the light from the LED light can injure your eyes.
- To extend the lifetime, the lithium-ion battery equips with the protection function to stop the output. Therefore, if the tool is overloaded, the motor may stop. However, this is not the trouble but the result of protection function. In this case, release the switch of tool and eliminate the causes of overloading.
- Before use, check to see if the lock-off button moves smoothly.

NOTE

Take care not to lock the motor. If the motor is locked, immediately turn the power off. If the motor is locked for a while, the motor or battery may be burnt.

1. Check if saw blade is tightened
While the saw blade is tightened securely for immediate use when it is assembled at the factory, be sure to check it out again for caution's sake. A bolt can be tightened when it is turned clockwise. Use the provided hex. bar wrench 5 mm to check it out. For further details, refer to the item of [PRIOR TO OPERATION] on Page 46.
2. Check if the lever is tightened
If the lever to adjust cutting depth (**Fig. 18 on page 48**) is loose, injury can result. Make sure that it is tightened securely.

3. Operation of switch (Fig. 24)

(switch trigger and light switch)

For safe operation of the machine, a “lock-off button” is provided on the side of a handle.

If the “switch trigger” is pulled in a state where “lock-off button” is pressed in the direction of the arrow mark, the main switch can be turned ON.

After the switch is on, the saw blade will continue to operate as long as you pull on the switch trigger, even if you release the lock-off button. Also, the LED light will remain lit for Always-ON mode as well as during SW interlocked mode.

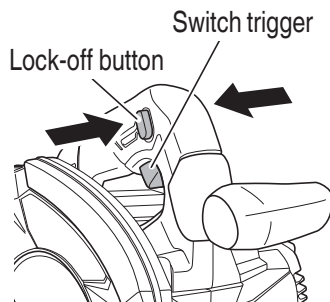

Fig. 24

4. About the mode select function

Each time the mode selector switch is pushed, the operation mode changes.

When Silent mode is selected, the Silent mode indicator lamp lights up.

Silent mode reduces maximum motor RPM enabling efficient work with less noise.

If the load increases while the motor is operating in Silent mode, it automatically changes to Power mode.

Additionally, if the load decreases again, it automatically returns to Silent mode.

In Power mode, no change is made to Silent mode even when the load decreases.

Mode	No-load speed
Power	3800 /min
Silent	2000 /min

NOTE

- The mode will only change after a battery is installed and the switch is pulled once.
- The current mode will be maintained even if the switch is on/off, or the battery is removed/reinserted.



English

5. About Remaining Battery Indicator

Remaining battery power can be verified by pulling on the switch to make the remaining battery indicator lamp light up red. **(Fig. 24 on page 51)**

The indicator lamp will change to the lighting mode indicator lamp (green) 10 seconds after the switch is released. The **Table 4** shows the state of remaining battery indicator lamp and the battery remaining power.

Table 4

State of lamp	Battery Remaining Power
	The battery remaining power is enough.
	The battery remaining power is a half.
	The battery remaining power is nearly empty. Re-charge the battery soonest possible.



As the remaining battery indicator shows somewhat differently depending on ambient temperature and battery characteristics, read it as a reference.

6. How to use the LED light

By pressing the lighting mode switch on the switch panel, the LED light mode changes as **Table 5**. It is indicated by green lamp. **(Fig. 25)**

To prevent the battery power consumption, turn off the LED light frequently.

Table 5

	Always-ON mode	SW interlocked mode	Always-OFF mode
Panel display			
State	Always ON (turn off after 2 minutes)	Light only SW-ON (Automatically goes out approximately 10 seconds after the switch is released)	Always OFF

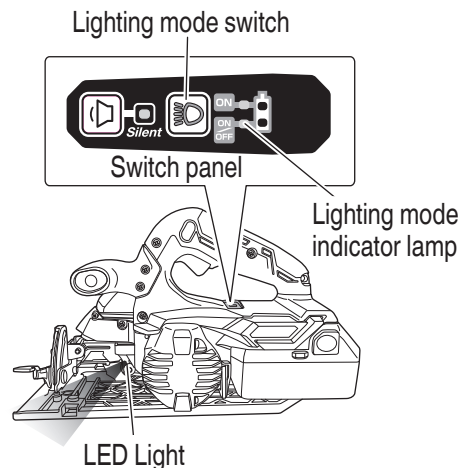

Fig. 25

CAUTION

- Do not expose directly your eye to the light by looking into the light. If your eye is continuously exposed to the light, your eye will be hurt.
- Wipe off any dirt or grime attached to the lens of the LED light with a soft cloth, being careful not to scratch the lens. Scratches on the lens of the LED light can result in decreased brightness.

NOTE

To prevent the battery power consumption caused by forgetting to turn off the LED light, the light goes off automatically in about 2 minutes.

7. Attaching the guide (sold separately)

Install the wing bolt (B) and lock spring on the base. Insert the guide into the base, move it left and right and adjust the cutting position. Tighten the wing bolt (B) and fix the guide. The guide can be installed either from the left or the right side of the main body.

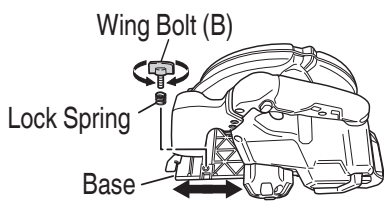
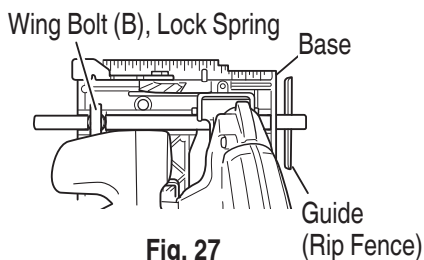
**Fig. 26****Fig. 27****WARNING**

When using the guide, avoid inclined cutting that will allow the cut material to be caught between the saw blade and the guide. Doing so may result in injury.

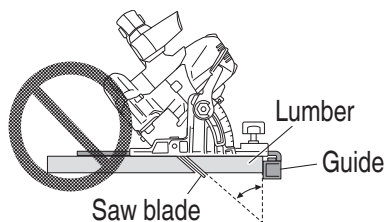
**Fig. 28**

English

8. Cutting procedures

CAUTION

- Recheck that the saw blade is securely clamped.
- Confirm that the lever for adjusting the slot depth, and the angle of inclination.

- (1) Place the base on the material, then align the premarked line and the saw blade with the notch at the front of the base (**Fig. 29**).
- (2) When the base is not inclined, use the right side of the notch (**Fig. 29, Fig. 30**).
If the base is inclined (45 degrees), use the left side of the notch (**Fig. 29, Fig. 31**).

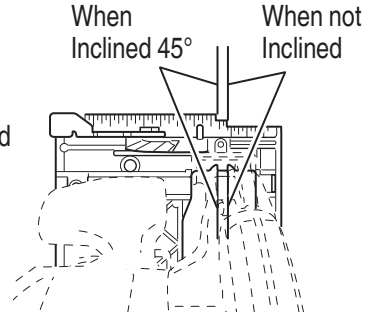

Fig. 29 <Top View>

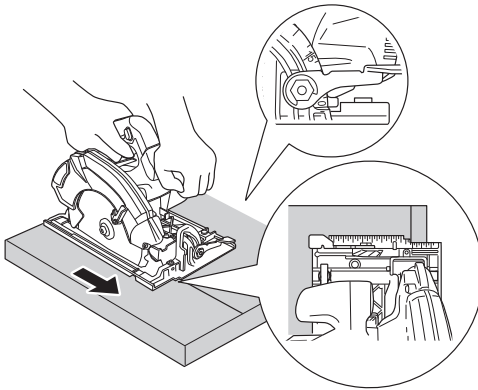

Fig. 30

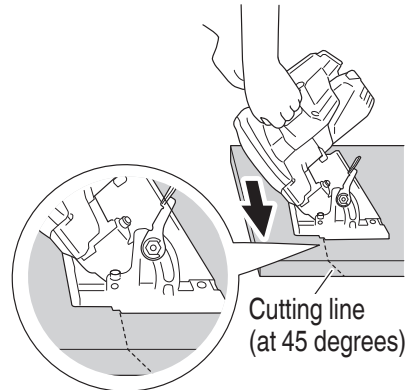

Fig. 31

NOTE

When using the saw at the inclination of 45 degrees, use both the marks of on the bevel plate and [45] on the inclined gauge of the base (**Fig. 32**).

What's more, if it is absolutely essential to use the saw at a precise angle, make adjustment using a protractor, etc.

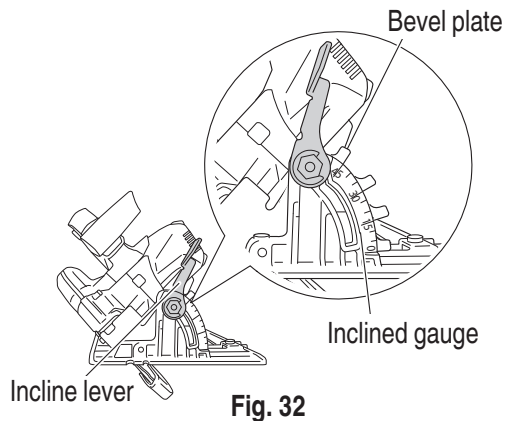

Fig. 32

- (3) Ensure that the switch is turned to the ON position before the saw blade comes in contact with the lumber. The switch is turned ON when the switch trigger is squeezed; and OFF when the switch trigger is released. Moving the saw straight at a constant speed will produce optimum cutting.

CAUTION

- Before starting to saw, ensure that the saw blade has reached full speed revolution.
- When finished with a job, pull out the battery from the main body.
- To avoid abnormal heating of the blade tip or damage to the saw blade, do not twist or apply excessive force to the saw blade when cutting. Let the blade move forward smoothly.
- In the situation where the circular saw is continuously operated while replacing the battery with stocked spare batteries one after another, the motor tends to overheat. Therefore, whenever the housing becomes hot, give the saw a break for a while.
- Avoid cutting operation in a state where the base bottom is afloat from the material being cut. Otherwise, the motor can get locked.

9. Pocket cutting

WARNING

- To avoid serious accident, ensure the switch is OFF position, and pull out battery before any adjustment.
- Never tie or wedge the lower guard in a raised position.

- (1) Mark the desired cutting area clearly with lines all side. (See Fig. 33)
- (2) Set depth adjustment according to material to be cut.
- (3) Push the lever all the way back so the blade is exposed as shown in Fig. 33.
- (4) Tilt saw forward and align the notch (Fig. 29) with the pre-marked guide line.
- (5) Release the lever. When the lower guard contacts the work piece surface, it will be in proper position to open freely when cutting is commenced.
- (6) Holding the saw in position, with the blade not contacting the work piece surface, pull the trigger.
- (7) After the saw has reached full speed, gradually lower rear end of the saw until its base rests on the work surface.
- (8) Advance saw along the cutting line up to the corner.
- (9) Release trigger and allow blade to stop completely before withdrawing the blade from the work piece.
- Never under any circumstances pull the saw backwards while the blade is in motion, as kickback may result.
- (10) Use a jig saw or hand saw to cut the corners out clean.
- (11) When starting each new cut, repeat as above.

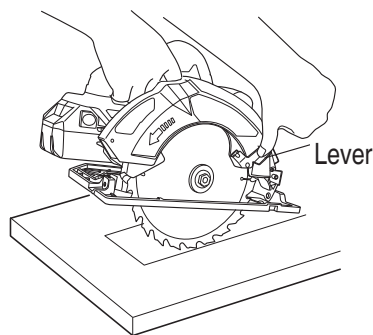

Fig. 33

LED LIGHT WARNING SIGNALS (Fig. 34)

This product features functions that are designed to protect the tool itself as well as the battery. While the switch is pulled, if any of the safeguard functions are triggered during operation, the LED light will blink as described in **Table 6**. When any of the safeguard functions are triggered, immediately remove your finger from the switch and follow the instructions described under corrective action.

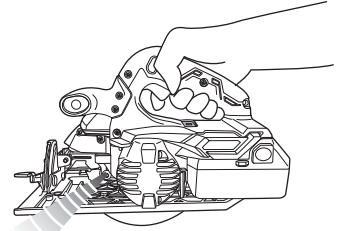

Fig. 34

Table 6

Safeguard Function	LED Light Display	Corrective Action
Overburden Protection	On 0.1 second/off 0.1 second ■ ■ ■ ■ ■ ■ ■ ■ ■ ■ ■ ■ ■ ■ ■ ■	Remove the cause of the overburdening.
Temperature Protection	On 0.5 second/off 0.5 second ■■■■ ■■■■ ■■■■	Allow the tool and battery to thoroughly cool.

MAINTENANCE AND INSPECTION

WARNING

Be sure to turn off the switch and pull out the battery before doing any inspection or maintenance.

- Inspecting the saw blade
 Continued use of a dull or damaged blade will result in reduced cutting efficiency and may cause overloading of the motor. Replace the blade with a new one as soon as excessive abrasion is noted.

CAUTION

If a dull saw blade is used, reactive force is increased during cutting operation. Avoid the use of the dull saw blade without repair.

- Check the Screws
 Loose screws are dangerous. Regularly inspect them and make sure they are tight.

CAUTION

Using this power tool with loosen, screws is extremely dangerous.

3. Motor unit maintenance

The motor winding is an important part of this tool. Avoid damaging and be careful to avoid contact with cleaning oil or water.

After 50 hours of use, clean the motor by blowing into the ventilation holes of the motor housing with dry air from an air gun or other tool (**Fig. 35**).

Dust or particle accumulation in the motor can result in damage.

4. Inspecting and maintaining the lower guard

Always make sure that the lower guard moves smoothly.

In the event of any malfunction, immediately repair the lower guard.

For cleaning and maintenance, use an air gun or other tool to blow clean the space between the lower guard and gear cover as well as the rotation part of the lower guard with dry air (**Fig. 35**).

Doing so is effective for the emission of chips or other particles.

Accumulation of chips or other particles around the lower guard may result in malfunction or damage.

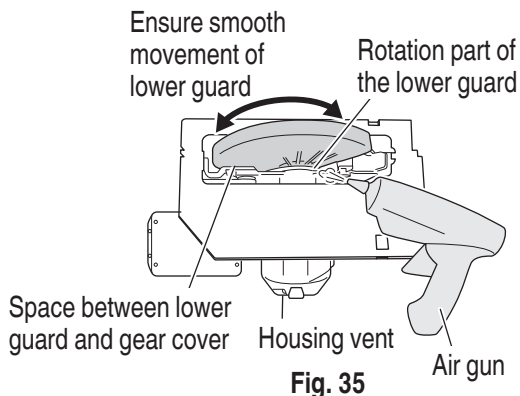
**WARNING**

To prevent dust inhalation or eye irritation, wear protective safety goggles and a dust mask when using an air gun or other tool to clean the lower guard, ventilation holes or other parts of the product.

5. Clean inside the saw cover

Periodically inspect and clean the saw cover to ensure that there is no accumulation of chips or other particles.

6. Adjusting the base and saw blade to maintain perpendicularity (**Fig. 36**)

The angle between the base and the saw blade has been adjusted to 90°, however should this perpendicularity be lost for some reason, adjust in the following manner.

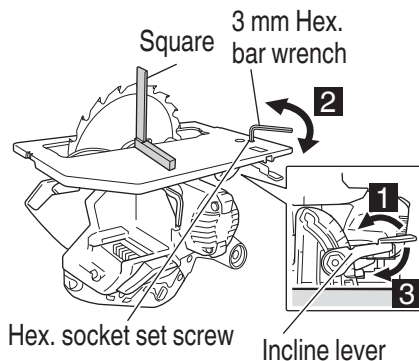

English

7. Inspection of terminals (tool and battery)
Check to make sure that swarf and dust have not collected on the terminals.
On occasion check prior, during and after operation.

CAUTION

**Remove any swarf or dust which may have collected on the terminals.
Failure to do so may result in malfunction.**

8. Cleaning of the outside
When the impact driver is stained, wipe with a soft dry cloth or a cloth moistened with soapy water. Do not use chloric solvents, gasoline or paint thinner, as they melt plastics.
9. Lubrication
The bearings in this tool have been sufficiently lubricated with quality lubricating oil, taking into account the expected life of this tool under normal operating conditions. As a result, no further lubrication is necessary.
10. Disposal of the exhausted battery

WARNING

Do not dispose of the exhausted battery. The battery may explode if it is incinerated. The battery is recyclable. At the end of its useful life, under various state and local laws, it may be illegal to dispose of this battery into the municipal waste stream. Check with your local solid waste officials for details in your area for recycling options or proper disposal.

11. Storage
Store the impact driver in a place in which the temperature is less than 40°C, and out of reach of children.

NOTE

Storing Lithium-ion Batteries

Make sure the batteries have been fully charged before storing them.

Prolonged storage (3 months or more) of batteries with a low charge may result in performance deterioration, significantly reducing battery usage time or rendering the batteries incapable of holding a charge.

However, significantly reduced battery usage time may be recovered by repeatedly charging and using the batteries two to five times.

If the battery usage time is extremely short despite repeated charging and use, consider the batteries dead and purchase new batteries.

CAUTION

In the operation and maintenance of power tools, the safety regulations and standards prescribed in each country must be observed.

Important notice on the batteries for the HiKOKI cordless power tools

Please always use one of our designated genuine batteries. We cannot guarantee the safety and performance of our cordless power tool when used with batteries other than these designated by us, or when the battery is disassembled and modified (such as disassembly and replacement of cells or other internal parts).

TROUBLESHOOTING

Use the inspections in the table below if the tool does not operate normally. If this does not remedy the problem, consult your dealer or the HIKOKI Authorized Service Center.

1. Power tool

Symptom	Possible cause	Remedy
Tool doesn't run	No remaining battery power	Charge the battery.
	The trigger switch was held down while the battery was inserted.	The safety function was activated. If the trigger switch is released once and then pulled again, the tool will run.
Tool suddenly stopped	Tool was overburdened	Get rid of the problem causing the overburden.
	The battery is overheated.	Let the battery cool down.
	The trigger switch was held down for 5 minutes or more.	This is not a malfunction. The motor was automatically stopped to prevent failure of the tool.
Cannot be inclined	The incline lever is not loosened.	Try inclining after loosening the incline lever. Tighten the loosened parts after making the necessary adjustments.
Doesn't cut well	The saw blade is worn or missing teeth.	Replace with a new saw blade.
	The bolt is loose.	Firmly tighten the bolt.
	The saw blade is installed backwards.	Install the saw blade in the proper direction.
Switch can't be pulled	Forward/reverse selector button is positioned halfway	Press the button firmly into position for the desired direction of rotation.
Sawdust discharge is poor	Sawdust has accumulated in the saw cover.	Remove the sawdust inside the saw cover.
Remaining battery indicator on the machine doesn't match to Multi volt battery	—	Refer to the indicator lamp on the battery.

SELECTING ACCESSORIES

Select accessories that are suited to a specific task.
For details contact HiKOKI Authorized Service Center.

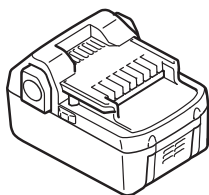

BSL18..
Battery

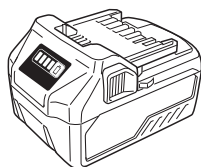

BSL36..18
Battery

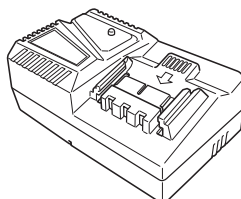

UC18YFSL
(14.4 V-18 V)
Charger

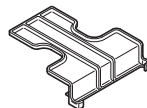

Part Number: 329897
Battery cover



321639

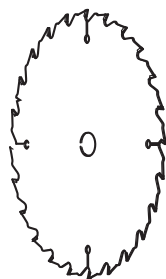

330888



333555



338917

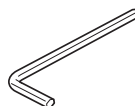

944459

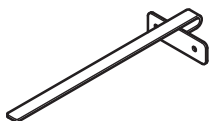

302691



377954

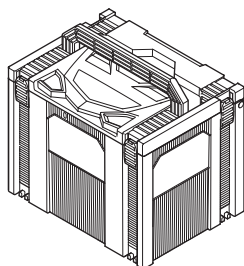

337528

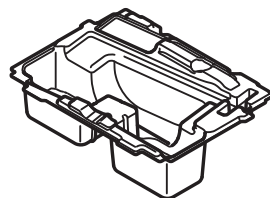

373646

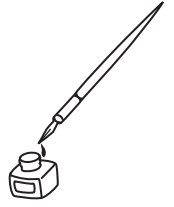

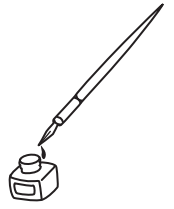

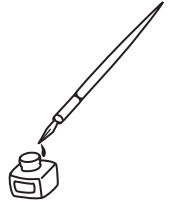

服务中心
高壹工机商业(上海)有限公司
上海市闵行区浦江工业园区三鲁路3585号7幢3楼

制造商
广东高壹工机有限公司
广东省广州市番禺区化龙镇工业路富裕围工业村

Koki Holdings Co., Ltd.

106

编号: C99741821 G
发行日期: 2021年 6月
中国印刷