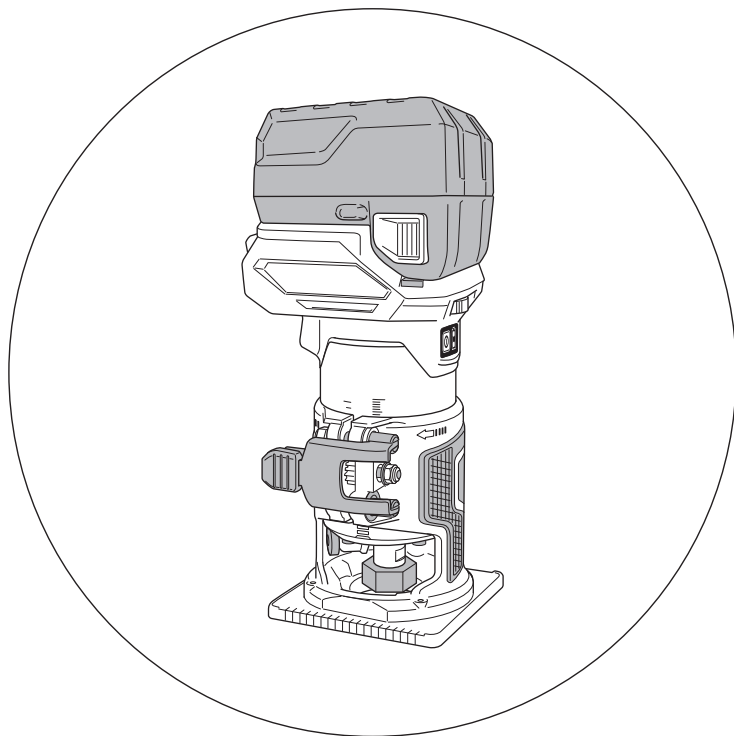


# HiKOKI

充电式木工修边机  
Cordless trimmer

中文  
English

## M 1808DA



保留备用  
Keep for future reference



使用说明书  
Handling instructions

## 目次

电动工具通用安全警告.....	2	电池的拆卸 / 安装法.....	11
充电式木工修边机安全警告.....	4	充电.....	11
其他安全警告.....	5	USB 设备的充电方法.....	14
锂离子电池使用注意事项.....	6	使用前.....	15
锂离子电池运输.....	7	安装和拆卸钻头.....	15
USB 设备连接器使用注意事项.....	8	作业之前.....	16
符号.....	8	操作.....	21
零件名称.....	8	操作注意事项.....	26
规格.....	9	维护和检查.....	27
标准附件.....	10	故障排除.....	29
用途.....	10	选择附件.....	32

## 电动工具通用安全警告

### 警告！

阅读所有警告和所有说明。

不遵照以下警告和说明会导致电击、着火和 / 或严重伤害。

保存所有警告和说明书以备查阅。

在所有下列的警告中术语“电动工具”指市电驱动（有线）电动工具或电池驱动（无线）电动工具。

#### 1) 工作场地的安全

a) 保持工作场地清洁和明亮。

混乱和黑暗的场地会引发事故。

b) 不要在易爆环境，如有易燃液体、气体或粉尘的环境下操作电动工具。

电动工具产生的火花会点燃粉尘或气体。

c) 让儿童和旁观者离开后操作电动工具。

注意力不集中会使操作者失去对工具的控制。

#### 2) 电气安全

a) 电动工具插头必须与插座相配。

绝不能以任何方式改装插头。

需接地的电动工具不能使用任何转换插头。

未经改装的插头和相配的插座将减少电击危险。

b) 避免人体接触接地表面，如管道、散热片和冰箱。

如果你身体接地会增加电击危险。

c) 不得将电动工具暴露在雨中或潮湿环境中。

水进入电动工具将增加电击危险。

- d) 不得滥用电线。绝不能用电线搬运、拉动电动工具或拔出其插头。  
使电线远离热源、油、锐边或运动部件。  
受损或缠绕的软线会增加电击危险。
- e) 当在户外使用电动工具时，使用适合户外使用的外接软线。  
适合户外使用的软线将减少电击危险。
- f) 如果在潮湿环境下操作电动工具是不可避免的，应使用剩余电流动作保护器（RCD）。  
使用RCD可减小电击危险。

### 3) 人身安全

- a) 保持警觉，当操作电动工具时关注所从事的操作并保持清醒。  
当你感到疲倦，或在有药物、酒精或治疗反应时，不要操作电动工具。  
在操作电动工具时瞬间的疏忽会导致严重人身伤害。
- b) 使用个人防护装置。始终佩戴护目镜。  
安全装置，诸如适当条件下使用防尘面具、防滑安全鞋、安全帽、听力防护等装置能减少人身伤害。
- c) 防止意外起动。确保开关在连接电源和 / 或电池盒、拿起或搬运工具时处于关断位置。  
手指放在已接通电源的开关上或开关处于接通时插入插头可能会导致危险。
- d) 在电动工具接通之前，拿掉所有调节钥匙或扳手。  
遗留在电动工具旋转零件上的扳手或钥匙会导致人身伤害。
- e) 手不要伸展得太长。时刻注意立足点和身体平衡。  
这样在意外情况下能很好地控制电动工具。
- f) 着装适当。不要穿宽松衣服或佩戴饰品。让衣服、手套和头发远离运动部件。  
宽松衣服、佩饰或长发可能会卷入运动部件中。
- g) 如果提供了与排屑、集尘设备连接用的装置，要确保它们连接完好且使用得当。  
使用这些装置可减少尘屑引起的危险。

### 4) 电动工具使用和注意事项

- a) 不要滥用电动工具，根据用途使用适当的电动工具。  
选用适当设计的电动工具会使你工作更有效、更安全。
- b) 如果开关不能接通或关断工具电源，则不能使用该电动工具。  
不能用开关来控制的电动工具是危险的且必须进行修理。
- c) 在进行任何调节、更换附件或贮存电动工具之前，必须从电源上拔掉插头和 / 或使电池盒与工具脱开。  
这种防护性措施将减少工具意外起动的危险。

## 中文

- d) 将闲置不用的电动工具贮存在儿童所及范围之外，并且不要让不熟悉电动工具或对这些说明不了解的人操作电动工具。  
电动工具在未经培训的用户手中是危险的。
- e) 保养电动工具。检查运动件是否调整到位或卡住，检查零件破损情况和影响电动工具运行的其他状况。如有损坏，电动工具应在使用前修理好。  
许多事故由维护不良的电动工具引发。
- f) 保持切削刀具锋利和清洁。  
保养良好的有锋利切削刃的刀具不易卡住而且容易控制。
- g) 按照使用说明书，考虑作业条件和进行的作业来使用电动工具、附件和工具的刀头等。  
将电动工具用于那些与其用途不符的操作可能会导致危险。

### 5) 电池式工具使用和注意事项

- a) 只用制造商规定的充电器充电。  
将适用于某种电池盒的充电器用到其他电池盒时会发生着火危险。
- b) 只使用配有特制电池盒的电动工具。  
使用其他电池盒会发生损坏和着火危险。
- c) 当电池盒不用时，将它远离其他金属物体，例如回形针、硬币、钥匙、钉子、螺钉或其他小金属物体，以防一端与另一端连接。  
电池端部短路会引起燃烧或火灾。
- d) 在滥用条件下，液体会从电池中溅出；避免接触。如果无意间碰到了，用水冲洗。如果液体碰到了眼睛，还要寻求医疗帮助。  
从电池中溅出的液体会发生腐蚀或燃烧。

### 6) 维修

- a) 将你的电动工具送交专业维修人员，使用同样的备件进行修理。  
这样将确保所维修的电动工具的安全性。

## 注意！

不可让儿童和体弱人士靠近工作场所。

应将不使用的工具存放在儿童和体弱人士接触不到的地方。

## 充电式木工修边机安全警告

1. 在操作过程中，切削工具可能会触碰到隐藏的线缆，因此请仅握住电动工具的绝缘夹持面。  
接触“带电”导线也会使电动工具的裸露金属部件“带电”，并可能造成操作者触电。
2. 请使用夹具或其他实用方法将工件固定并支撑在稳定的平台上。  
用手或身体抓持工件将使工件不稳，并可能导致失控。
3. 长时间使用工具时，请始终佩戴护耳器。  
长时间接触高强度噪音可能导致听力损失。

4. 小心操作钻头。
5. 操作前，请仔细检查钻头是否破裂或损坏。立即更换破裂或损坏的钻头。
6. 避免割到铁钉。操作前，请检查并拆下工作材料上的所有铁钉。
7. 操作时请确保牢牢握住工具。否则可能导致事故或受伤。（第 24 页的图 31）
8. 须将手远离电动工具旋转部分。
9. 打开开关前，确保钻头未接触工作材料。
10. 让工具先运转一会，再将其用于实际工作材料上。振动或摆动可能表明钻头安装不当，请注意。
11. 注意钻头的旋转方向和送入方向。
12. 作业时请勿离开电动工具。该电动工具仅支持手持作业。
13. 从工作材料上移除工具之前，务必先将其关闭并等待钻头完全停止。
14. 操作后切勿立即触摸钻、轴、夹头螺母和夹头锥：可能会因过烫而灼伤皮肤。
15. 更换钻头或进行任何调整后，请确保已牢固旋紧弹性夹头和其他任何调整装置。  
松动的调整装置可能会意外移动，从而导致失控，此时松动的旋转部件会被大力抛出。
16. 保证作业全程佩戴安全护目镜。
17. 由于充电式电动工具是电池供电的，因此请注意工具可能会随时开始运转。
18. 使用柄直径适合工具速率的钻。
19. 操作工具时，请勿佩戴工作手套，因为手套的布料可能会卷入工具中。

## 其他安全警告

1. 务请在 $0^{\circ}\text{C}$ — $40^{\circ}\text{C}$ 的温度下进行充电。温度低于 $0^{\circ}\text{C}$ 将会导致充电过度，极其危险。电池不能在高于 $40^{\circ}\text{C}$ 的温度下充电。  
最适合于充电的温度是 $20$ — $25^{\circ}\text{C}$ 。
2. 不要连续使用充电器。  
一次充电完毕后，在15分钟内不要再次使用该充电器对电池充电。
3. 请勿让杂质进入充电式电池连结口内。
4. 切勿拆卸充电式电池与充电器。
5. 切勿使充电式电池短路。电池短路会引起强电流和过热。从而烧坏电池。
6. 请勿将电池丢入火中。电池受热将会爆炸。
7. 充电后电池寿命太短不够使用时，请尽快将电池送往经销店。请勿将用过的电池乱丢。
8. 请勿将异物插入充电器的通风口。若将金属异物或易燃物插入通风口，将会引起触电事故或使充电器受损。
9. 长时间连续使用本机，可能导致机体过热，对马达及开关造成损害。因此，机壳变热时，请让工具休息一段时间。
10. 请确保蓄电池安装牢固。电池松动后，可能脱落并引起事故。

## 中文

11. 请勿使用工具或电池端子（电池安装部位）明显变形的产品。  
否则，安装电池后可能会短路，造成冒烟或起火。
12. 请清除工具端子（电池安装部位）上的削屑和灰尘。
  - 使用前，请确保电池上没有堆积削屑和灰尘。
  - 在使用过程中，请尽量避免工具上的削屑或灰尘掉落到电池上。
  - 暂停不使用工具时或使用后，应将工具存放在不会掉落削屑或灰尘的地方。  
否则可能短路，造成冒烟或起火。
13. 请在-5—40℃环境下使用本工具及电池。

## 锂离子电池使用注意事项

为延长使用期限，锂离子电池备配停止输出的保护功能。

若是在使用本产品时发生下列 1 和 3 的情况，即使按下开关，马达也可能停止。这并非故障，而是启动保护功能的结果。

1. 在残留的电池电力即将耗尽时，马达会停止。  
在这种情况下，请立即予以充电。
2. 若工具超过负荷，马达亦可能停止。在这种情况下，请松开工具的开关，试着消除超过负荷的原因。之后您就可以再度使用。
3. 若电池在过载工作情况下过热，电池电力可能会中止。  
在这种情况下，请停止使用电池，让电池冷却。之后您就可以再度使用。

此外，请留心下列的警告及注意事项。

### 警告！

为防止发生电池漏电、发热、冒烟、爆炸及提前点燃，请确保留意下列事项。

1. 确保电池上没有堆积削屑及灰尘。
  - 在工作时确定削屑及灰尘没有掉落在电池上。
  - 确定所有工作时掉落在电动工具上的削屑和灰尘没有堆积在电池上。
  - 请勿将未使用的电池存放在曝露于削屑和灰尘的位置。
  - 在存放电池之前，请清除任何可能附着在上面的削屑和灰尘，并请切勿将它与金属零件（螺丝、钉子等）存放在一起。
2. 请勿以钉子等利器刺穿电池、以铁锤敲打、踩踏、丢掷电池，或将其剧烈撞击。
3. 切勿使用明显损坏或变形的电池。
4. 使用电池时请勿颠倒电极。
5. 请勿直接连接电源插座或汽车点烟器孔座。
6. 请依规定方式使用电池，切勿移作他用。
7. 如果已过了再充电时间，电池仍无法完成充电，请立即停止继续再充电。
8. 请勿将电池放置于高温或高压处，例如微波炉、烘干机或高压容器内。
9. 在发觉有渗漏或异味时，请勿接近远离火源。
10. 请勿在会产生强烈静电的地方使用。

11. 如有电池渗漏、异味、发热、褪色或变形，或在使用、充电或存放时出现任何异常，请立即将它从装备或电池充电器拆下，并停止使用。
12. 请勿浸泡电池或让任何液体流入电池内部。导电液体进入（如水），可能造成电池损坏，甚至可导致火灾或爆炸。将电池存放在阴凉、干燥的地方，远离易燃物品。必须避免将电池置于腐蚀性气体环境中。

## 注意！

1. 若电池渗漏出的液体进入您的眼睛，请勿搓揉眼睛，并以自来水等干净清水充分冲洗，立刻送医。  
若不加以处理，液体可能会导致眼睛不适。
2. 若液体渗漏至您的皮肤或衣物，请立即以自来水等清水冲洗。  
上述情况可能会使皮肤受到刺激。
3. 若初次使用电池时发现生锈、异味、过热、褪色、变形及 / 或其它异常情况时，请勿使用并将该电池退还给供货商或厂商。

## 警告！

如果有导电异物进入锂电池，可能发生短路，并有发生火灾危险的可能。请在贮存电池时，遵守如下事项。

- 请不要在电池盒内放置导电物体，如钉子、钢丝、铜丝或其他电线。
- 或者将电池装在电动工具中，或者在牢固按入电池盖并挡住通风孔后再存放，以防止短路（图 1）。

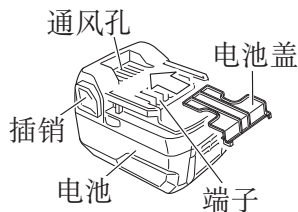


图 1

## 锂离子电池运输

当运输一个锂离子电池，请注意以下预防措施。

## 警告！

告知运输公司，包装内包含一个锂离子电池，告知该公司其功率输出并且要按照运输公司的指引安排运输。

- 功率输出超过 100Wh 的锂离子电池被视作危险物品运输分类并且需要特别申请程序。
- 对于境外运输，您必须遵守国际法以及输入国的规章和条例。

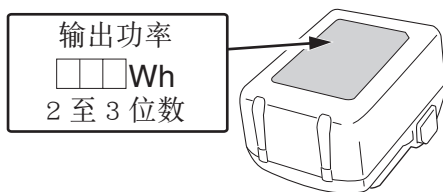


图 2







## 2. 电池 (选购件 ... 单独出售)

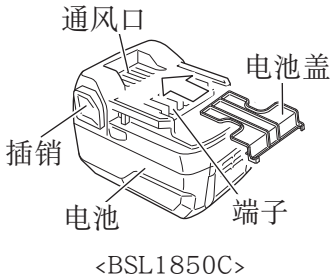


图 4

## 3. 电池充电器 (选购件 ... 单独出售)

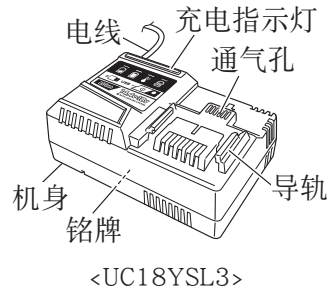


图 5

## 规格

## 电动工具

型式	M1808DA
电压	18V
弹性夹头容量	6.35mm
空载速度	10000 - 30000/min
电池	BSL1850C : 锂离子 18V (5.0Ah, 5 节)
重量	1.7kg (附 BSL1850C 和碎屑收集器)

注：  
可用钻头：直钻头、修边钻头、倒角钻头、圆角钻头、榫口钻头、燕尾钻头。


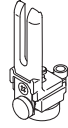
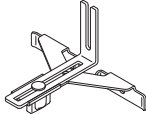



## 充电器 (单独出售)

型式	UC18YSL3
充电电压	14.4V - 18V
重量	0.6kg

## 标准附件

除了主机 (1 台) 外，产品包中还包括表中所列的附件。

表 1

		M1808DA (NN)
1/4" 夹头锥		1
木工修边机导轨		1
直导架		1
模板导架		1
碎屑收集套件		1
23mm 扳手		1

## 用途

○ 木工工作的重点是开槽和斜切。

例如开槽、斜切、切割、仿形切削、雕刻、仿形切割、组合等。

## 电池的拆卸 / 安装法

### 1. 电池的拆卸法

请先紧抓住把手，然后再推压电池插销（2个）以拆下电池（图6）。

### 注意！

切勿使电池短路。

### 2. 电池的安装法

插入电池时请注意极性（图6）

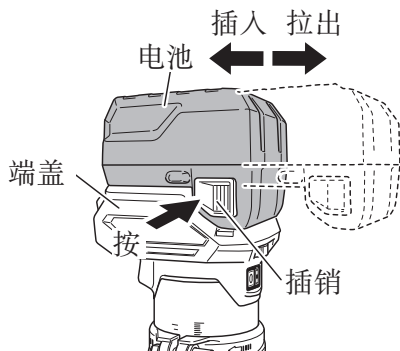


图 6

## 充电

使用电动工具之前，按下述方法将电池进行充电。

### 1. 将充电器的电源线连接到插座。

将充电器插头连接到插座时，指示灯闪烁红色（间隔为1秒）。

### 2. 将电池插入充电器。

如图7所示，将电池紧紧地插入充电器。

### 3. 充电

将电池插入充电器后，充电指示灯将呈蓝色闪烁。

电池完全充电后，充电指示灯将持续点亮呈绿色。

（参照第12页的表2）

#### (1) 充电指示灯的指示状态

根据充电器或可充电电池的情况，充电指示灯的显示如第12页的表2所示。

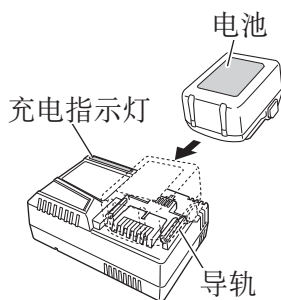





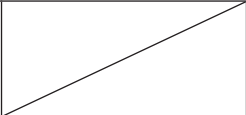




图 7

表 2

充电指示灯的指示状态				
充电指示灯 (红 / 蓝 / 绿 / 紫)	充电前	闪烁 (红)	点亮 0.5 秒钟。不点亮 0.5 秒钟。(熄灭 0.5 秒钟) 	插入电源
	充电时	闪烁 (蓝)	点亮 0.5 秒钟。不点亮 1 秒 钟。(熄灭 1 秒钟) 	电池电量低于 50%
		闪烁 (蓝)	点亮 1 秒钟。不点亮 0.5 秒钟。(熄灭 0.5 秒钟) 	电池电量低于 80%
		点亮 (蓝)	连续点亮 	电池电量高于 80%
	充电 完成	点亮 (绿)	连续点亮  (发出持续蜂鸣声: 约 6 秒)	
	过热 待机	闪烁 (红)	点亮 0.3 秒钟。不点亮 0.3 秒钟。(熄灭 0.3 秒钟) 	电池过热。无法充 电 (电池冷却后将 开始充电)
	无法 充电	闪动 (紫色)	点亮 0.1 秒钟。不点亮 0.1 秒钟。(熄灭 0.1 秒钟)  (发出断续蜂鸣声: 约 2 秒)	电池或充电器故障

- (2) 可充电电池温度和充电时间相关资料  
温度和充电时间如表 3 所示。

表 3

充电器		UC18YSL3					
电池	电池类型	锂离子电池					
	电池可充电温度	0°C – 50°C					
	充电电压	V	14.4		18		
	充电时间 (环境温度 20°C)	分钟	BSL14xx 系列		BSL18xx 系列		多电压系列
			(4 节)	(8 节)	(5 节)	(10 节)	(10 节)
			BSL1415S : 15 BSL1415 : 15 BSL1415X : 15 BSL1420 : 20 BSL1425 : 25 BSL1430C : 30	BSL1430 : 20 BSL1440 : 26 BSL1450 : 32 BSL1460 : 38	BSL1815S : 15 BSL1815 : 15 BSL1815X : 15 BSL1820 : 20 BSL1825 : 25 BSL1830C : 30 BSL1850C : 32	BSL1830 : 20 BSL1840 : 26 BSL1850 : 32 BSL1860 : 38	BSL36A18 : 32 BSL36B18 : 52 BSL36C18 : 20
USB	充电电压	V	5				
	充电电流	A	2				

注：

充电时间可能会因环境温度和电源电压而异。

4. 从电源插座拔下充电器的电源线。
5. 握紧充电器并取出电池。

注：

充电后，先将电池从充电器中取出，然后妥善保管。

#### 关于新电池的放电

新电池内部的化学物质未被激活或电池长时间不使用时，初次或第二次使用时需要将其放电至较低电量。这只是暂时现象，将电池充电 2-3 次即可恢复为充电所需的正常时间。

#### 较长时间保持电池性能的方法

- (1) 在电池电力完全耗尽之前进行充电。

感到电动工具的能力变弱时，请停止使用并给电池充电。若您继续使用电动工具并耗尽电力，电池可能会损坏或其使用寿命缩短。

## 中文

### (2) 避免在高温环境中充电。

使用后可充电电池的温度将迅速升高。若使用后立即对这种电池进行充电，其内部化学物质会劣化，电池使用寿命将缩短。请稍等片刻，待电池冷却后再进行充电。

## 注意！

- 如果电池长时间放置在阳光直射的地方或者刚刚使用完毕时，电池会变热。如果此时对电池充电，充电器的充电指示灯会点亮 0.3 秒钟，然后熄灭 0.3 秒钟（熄灭 0.3 秒钟）。此时请等待电池冷却后再开始充电。
- 充电指示灯闪动（闪动间隔为 0.2 秒钟）时，请检查充电器的电池连接器内是否有异物并加以清除。如没有异物，则可能是电池或充电器发生了故障。请将其送往当地授权服务中心。

## USB 设备的充电方法

### 警告！

- 使用之前请检查 USB 连接线缆是否有破损或损坏。  
使用有破损或损坏的 USB 线缆可能会导致冒烟或着火。
- 不使用产品时，请用橡胶盖封好 USB 端口。  
USB 端口中落入灰尘等可能会导致冒烟或着火。

### 注：

- USB 充电过程中，可能会有偶尔暂停。
- USB 设备未充电时，请将充电器上拔下 USB 设备。  
否则不仅会减少 USB 设备的电池寿命，还会导致意外事故。
- 根据设备类型，可能无法对部分 USB 设备进行充电。

### (1) 选择充电方式

根据所选的充电方式，将电池插入充电器或连接电源线插入插座。

- 将 USB 设备插入插座进行充电（图 8-a）。
- 将 USB 设备和电池插入插座进行充电。（图 8-b）

### (2) 连接 USB 线缆。（图 9）

拨下橡胶盖并将市售的 USB 线缆（匹配充电的设备）紧紧插入 USB 端口。

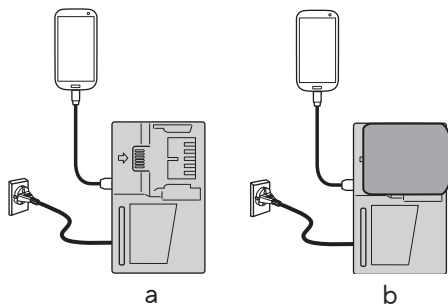


图 8

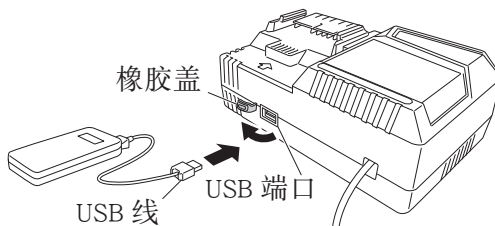


图 9

## (3) 充电完成时

- 检查 USB 设备以检验充电状态。
- 从插座中拔下电源线。(图 10)
- 用橡胶盖盖住 USB 端口。

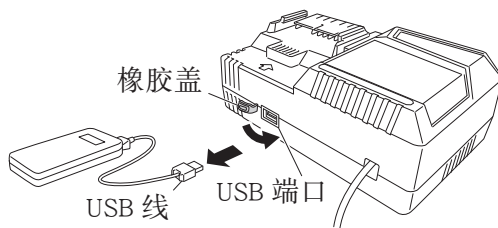


图 10

## 使用前

### 警告！

为避免引发严重事故，请按下位于开关面板上的电源按钮关闭电源，然后取出电池。

检查工作区域环境。

检查工作区域，确保没有杂物且不杂乱。

请勿使无关人员靠近。确保照明和通风充足。

## 安装和拆卸钻头

### 警告！

为避免引发严重事故，请按下位于开关面板上的电源按钮关闭电源，然后取出电池。

使用随附的 23mm 扳手拧紧夹头螺母。

使用非随附的工具可能会导致过紧或过松，从而引发人身伤害。

#### 1. 使用锁销安装

- (1) 从主体上拆下底座组件。
- (2) 将钻头深深地插入夹头锥孔中。(距夹头螺母侧 15mm 以上。)
- (3) 在钻头插入时，按下用于固定轴的固定锁销，使用 23mm 扳手以顺时针方向（从工具下方看）拧紧夹头螺母。(图 11)
- (4) 调整底座组件的小齿轮后，将拆下的底座组件安装到主体外壳的齿条上。然后将固定杆向固定侧倾斜，并牢牢固定底座组件。

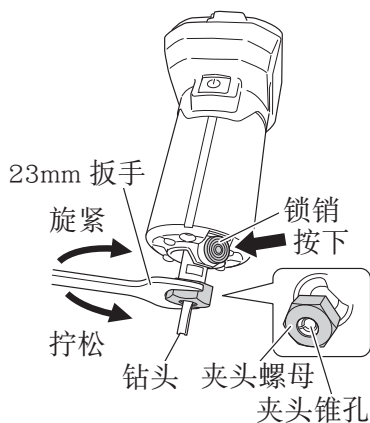


图 11

拆卸钻时，请按照与安装钻相反的步骤操作。



## 中文

### 2. 不使用锁销安装

- (1) 从主体上拆下底座组件。
- (2) 将钻头深深地插入夹头锥孔中。(距夹头螺母侧 15mm 以上。)
- (3) 使用 13mm 扳手固定轴，并用随附的扳手拧紧夹头螺母。(图 12)
- (4) 调整底座组件的小齿轮后，将拆下的底座组件安装到主体外壳上的齿条上。然后将固定杆向固定侧倾斜，并牢牢固定底座组件。

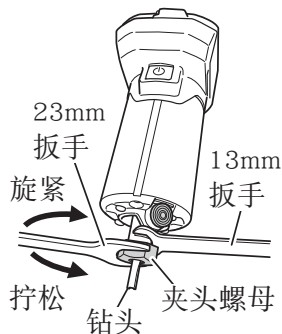


图 12

拆卸钻时，请按照与安装钻相反的步骤操作。

### 注：

- 确保在钻插入时，拧紧夹头螺母。如钻未放置到位就拧紧夹头锥，夹头锥可能会变形。
- 确保在拧紧夹头锥后，锁销没有插入轴中。否则会导致锁销和轴损坏。
- 只使用最大速度超过木工修边机最大速度的钻（钻上标出了该速度）。

### 3. 更换夹头锥

- (1) 固定轴，拆下夹头螺母，更换夹头锥。
- (2) 装上螺母，插入钻，拧紧螺母。(图 13)

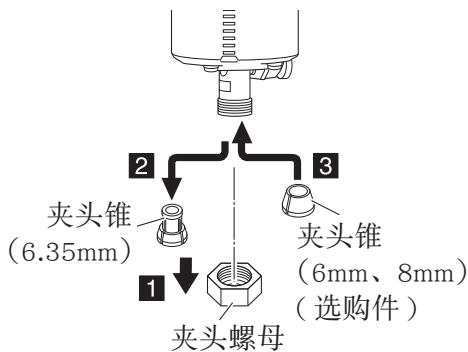


图 13

## 作业之前

### 警告！

为避免引发严重事故，请按下位于开关面板上的电源按钮关闭电源，然后取出电池。

### 1. 底座组件的安装方向

可根据意向，通过反转底座组件的安装方向更改开关位置。

- (1) 将固定杆朝拆卸侧倾斜，然后从主体上拆下底座组件。(图 14-a)
- (2) 旋转 180 度，放回底座组件，然后将固定杆朝固定侧倾斜。(图 14-b)

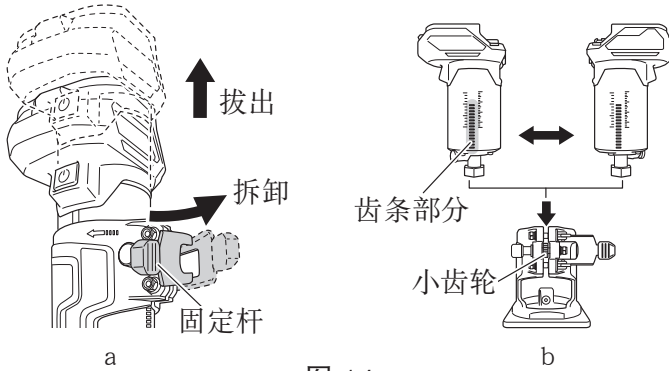


图 14

## 2. 固定强度调整方法

固定强度降低时，调整如下。

将固定杆朝固定侧倾斜，然后使用套筒扳手（8mm）拧紧固定螺母（两处）。（图 15-a）

固定好，使底座组件的上下间隙“A”一致。（图 15-b）

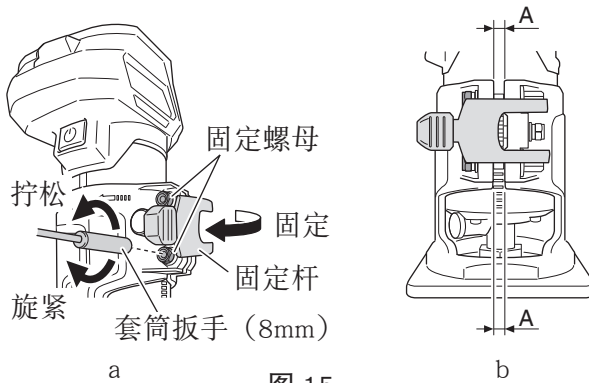


图 15

注：

如果固定杆的操作负荷过重，则固定强度过大。

此时可能会损坏零件，因此请松开每个固定螺母（两处），重新调整固定强度。

# 中文

## 3. 调整切削深度

- (1) 将工具置于平坦的木质表面上。
- (2) 将固定杆朝拆卸侧倾斜，然后转动捏手螺栓(A)降低本装置，直至钻的前端轻抵材料。在该位置处，可读取上端刻度。(图 16)
- (3) 向上转动捏手螺栓(A)，根据读取位置将刻度调整到所需的切割深度。

注：

请将单次的切割深度限制在 5mm 以内。

## 4. 引导木工修边机

### 警告！

为避免引发严重事故，请按下位于开关面板上的电源按钮关闭电源，然后取出电池。

### < 样板导轨 >

对于不同材料的相同形状，使用样板来处理非常便利。

(这时，可使用 6.35×6.35mm 的直钻。)

- (1) 将底座组件从机身上卸下。
- (2) 将样板导轨嵌入底座组件的凹部，并用两颗螺丝固定。(图 17)

注：

适度拧紧两颗螺丝。最佳拧紧力矩为 10 至 15kg·cm。

- (3) 将底座组件安装到机身中。

### 注意！

安装样板导轨时，样板导轨的上部不可接触夹头螺母。

沿样板内平面使用木工修边机时，成品尺寸将比样板尺寸小“B”尺寸的量，即样板导轨半径与钻半径之差。沿样板外部使用木工修边机时，情况相反。(图 18)

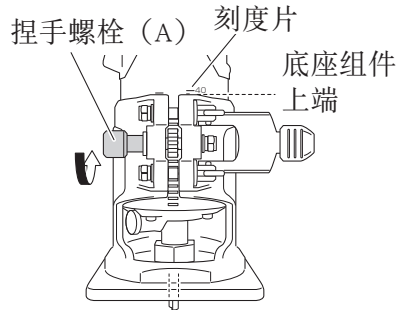
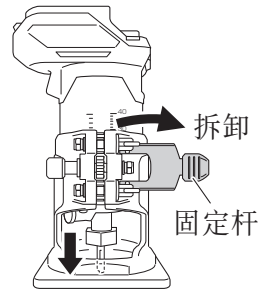
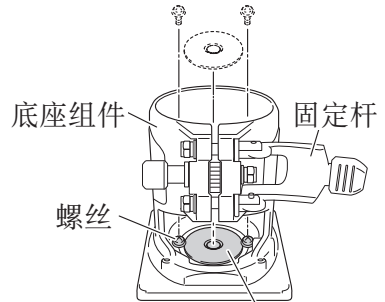


图 16



模板导轨

图 17

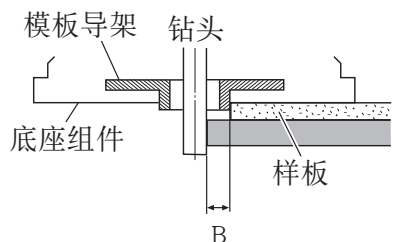


图 18

将样板固定到工件上。以样板导轨沿样板移动的方式送入木工修边机，如图 19 所示。

### <木工修边机导轨>

该导轨十分便于胶合板的修边和做斜边等材料加工。

- (1) 用捏手螺栓(B)将木工修边机导轨安装在底座组件上。
- (2) 松开捏手螺栓(B)以上下移动木工修边机导轨。
- (3) 松开捏手螺栓(C)并转动停止螺钉以移动导销。(图 20)移动导销后，拧紧捏手螺栓(C)，将其固定。
- (4) 如图 21 所示，将底座组件底部牢牢连接到材料的处理表面。将导销与材料一起送入木工修边机。

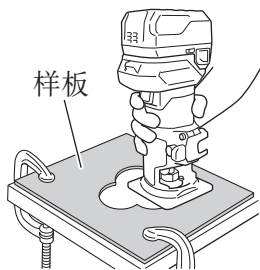


图 19

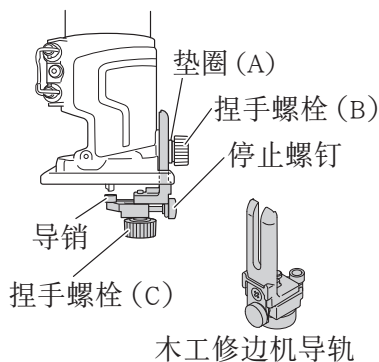


图 20

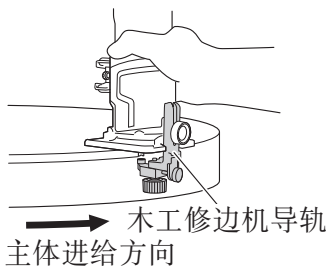


图 21

### <直导架>

○ 用于做斜边、切槽等直线加工作业时，十分便利。

- (1) 将带捏手螺栓(B)的直导轨安装在底座组件上并加以固定。
- (2) 通过松开蝶形螺母并根据需要移动直导轨，调整从钻到直导轨表面的长度“C”。(图 22)

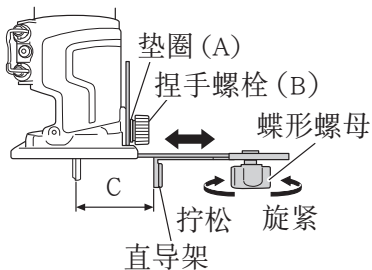
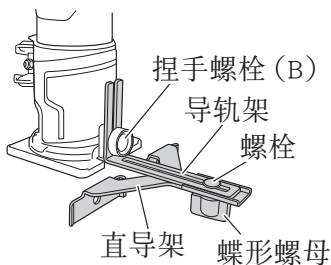


图 22

## 中文

(3) 如图 23 所示, 将底座组件底部牢牢连接到材料的处理表面。送入木工修边机, 同时使导面保持在材料表面上。

注:

使用直导架时, 请务必将其安装在送入方向的右侧。这样有利于和工作材料的侧面保持齐平。

○ 用导轨架更换直导轨后, 该工具可用于圆形切割工作。

[加工范围(旋入口至钻中心的距离)]

最小: 84mm

最大: 182mm

请注意, 无法加工尺寸为 102-124mm 和 143-158mm 的圆。

- (1) 转动蝶形螺母并拆下螺栓和垫圈 (2 片)。
  - (2) 翻转直导轨的顶部和底部并将其安装到导轨架上。(图 24)
- 根据待加工的圆的半径而定, 蝶形螺母和螺栓的孔有所不同。

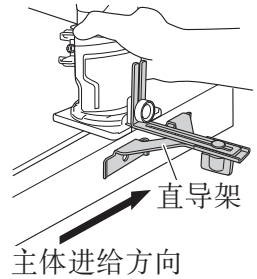


图 23

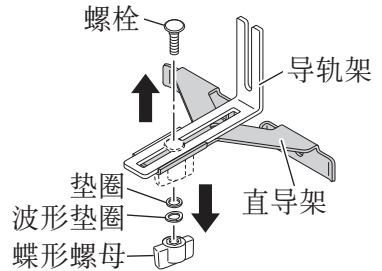
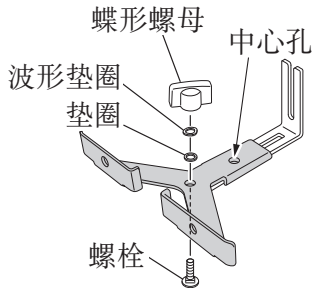


图 24

加工半径为 84-102mm 的圆



加工半径为 124-182mm 的圆

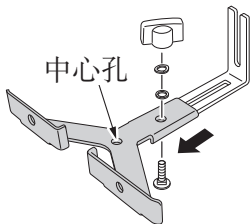


图 25

- (3) 工具安装方式与直线加工相同。
- (4) 将直导轨的孔对准圆形加工的中心位置，并用直径小于 6mm 的铁钉作为旋转轴牢牢固定。将主体向右旋转。(图 26)

#### < 碎屑收集套件 >

连接碎屑收集套件的吸尘器进行除尘。

- (1) 将碎屑收集器内侧的突出部分嵌入底座组件前左下方的定位孔中，并安装好以盖住底座组件的前部。(图 27-a)
- (2) 使用随附的捏手螺栓 (D) 将碎屑收集器孔固定到机身的螺丝孔中。(图 27-b)

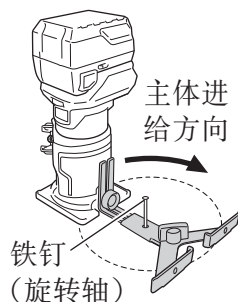


图 26

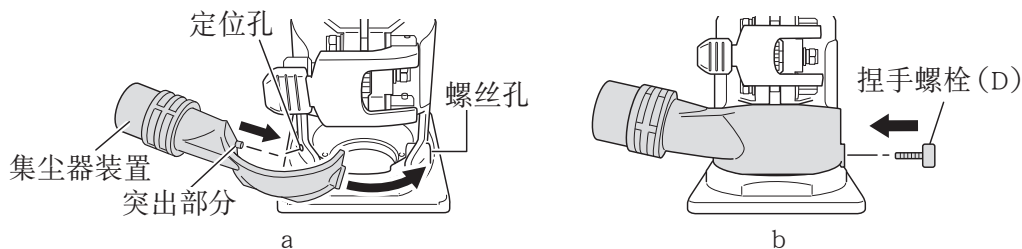


图 27

## 操作

### 警告！

- 为避免引发严重事故，请按下位于开关面板上的电源按钮关闭电源，然后取出电池。
- 操作该工具时，请戴上护目镜。
- 操作工具时，请确保手部、面部和其他身体部位远离钻头和任何其他旋转部位。

### 注意！

- 为延长使用期限，锂离子电池配备了停止输出的保护功能。因此，若工具超过负荷，电机也会停止。然而，这并非故障问题，而是保护功能起作用的结果。在这种情况下，请松开工具的开关，试着消除超过负荷的原因。
- 完成作业后，取出电池。

# 中文

## 1. 开关操作

按下电源按钮后再按下开关按钮，本装置运行。（图 28）

有关按钮控件的规格，请参见图 29。

剩余电池电量指示灯和 LED 灯与电源按钮联动。

如果电源打开且约 10 秒内未操作工具，则电源将自动关闭，剩余电池电量指示灯和 LED 灯也同时关闭。

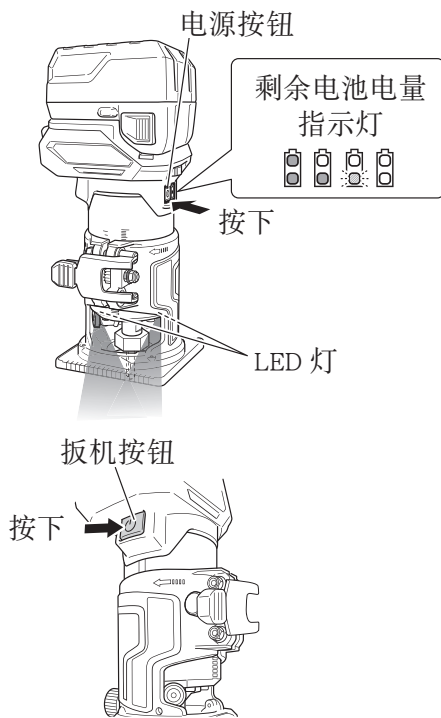


图 28



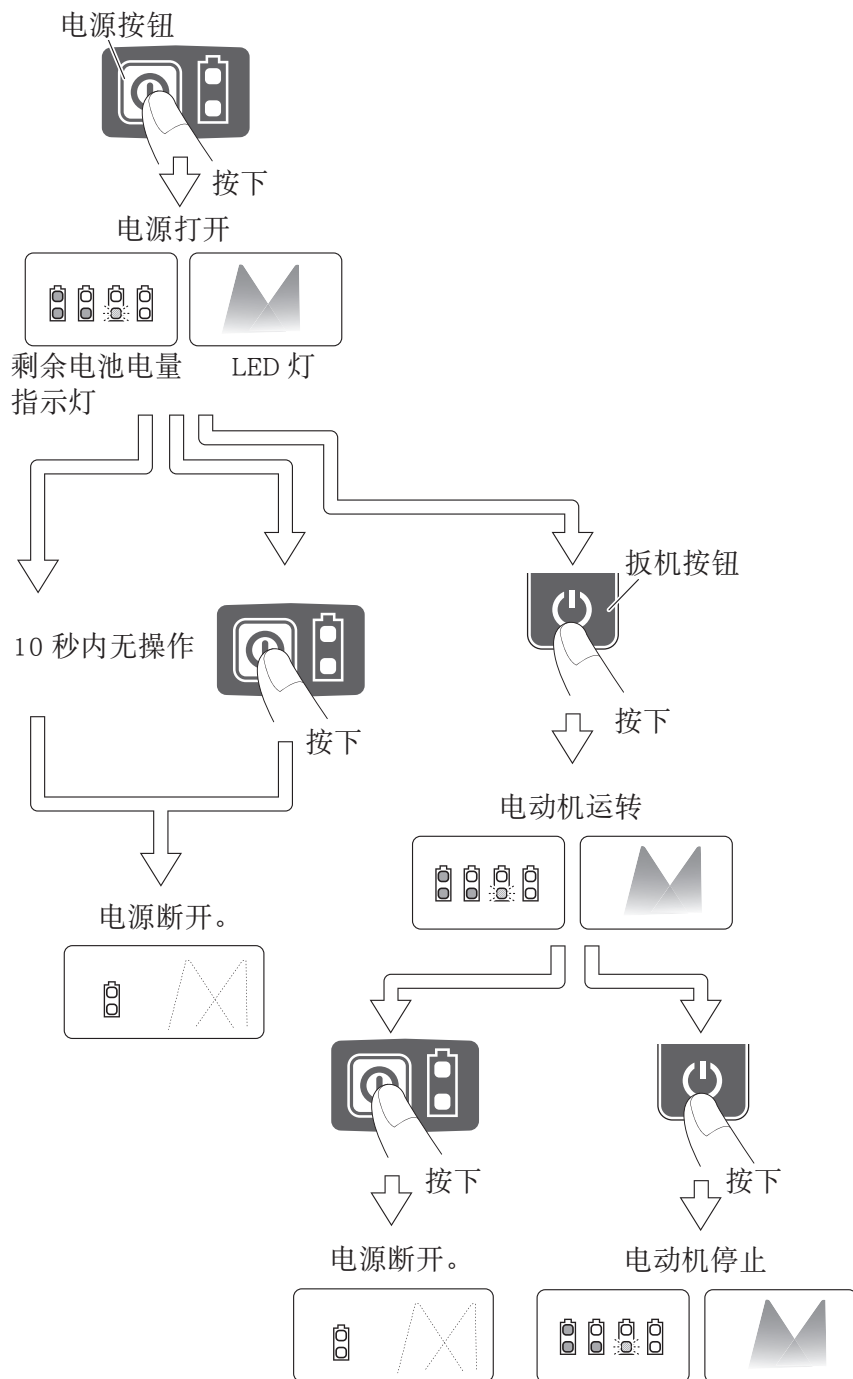


图 29

## 注意！

请勿直视 LED 灯光。持续或直接暴露在 LED 灯光下可能会导致视力受损。

### 2. 调节转速

M1808DA 装有允许转速变化的电子控制系统。如图 30 所示,拨盘位置“1”表示最小速度,位置“6”表示最大速度。

### 3. 切割操作

## 注意！

加工材料的一侧时, 确保待加工侧位于材料送入方向上钻头的左侧。

将待加工侧放在钻头的右侧会与钻头的旋转方向相反, 并可能导致电动机停止。在这种情况下, 负载过高可能会导致故障。

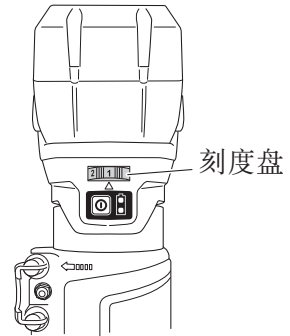


图 30

## 注：

- 请勿在电动机旋转时按下锁销。此外, 请勿在按下锁销的同时打开工具。否则可能会损坏锁销和 / 或电枢轴并导致人身伤害。
- 请将单次切割的切割深度限制在 5mm 以内。
- 切割深槽时, 需重复切割两三次。  
深切操作会使工具难以控制, 并可能使电动机过载, 从而导致故障。
- 快速前移工具可能会导致切割质量不佳, 或导致钻头或电动机损坏。工具前移太慢可能会烧坏切割部分。  
恰当的送入速率取决于钻头尺寸、工作材料种类和切割深度。在开始切割实际工作材料前, 建议在一块废木材上进行试切割。这将准确呈现切割效果, 并可进行尺寸检查。
- 异常和过载会触发过载保护器, 并中止操作。立即移除负载, 关闭电源, 然后再次打开。转速应可恢复正常。

为了将工作做得准确无误, 建议使用适合于工种的适当导轨。

(参看“引导木工修边机”。) 要加工的工件应加以紧固。

(1) 打开开关之前, 使钻与工件分开, 并将主体握紧。

(图 31)

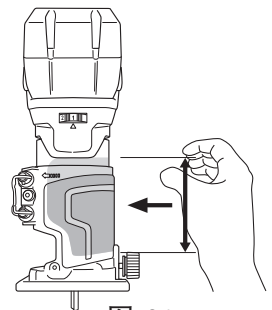






图 31



## 5. 关于剩余电量指示灯

电源打开时，剩余电池电量指示灯亮起，可检查电池的剩余电量。（图 34）  
表 5 显示剩余电池电量指示灯和电池剩余电量的状态。

表 5

指示灯状态	电池剩余电量
	电池剩余电量充足。
	电池剩余一半电量。
	电池剩余电量即将耗尽。 请尽快对电池进行充电。
	剩余电量不足

### 注：

- 如果剩余电池电量指示灯中仅剩一盏闪烁，则表明剩余电池电量很低。电池应尽快充电。
- 请勿强烈撞击或破坏显示面板。否则可能会导致故障。

环境温度和电池特性不同，则所显示的电池剩余电量也会有些许不同，以上内容仅供参考。

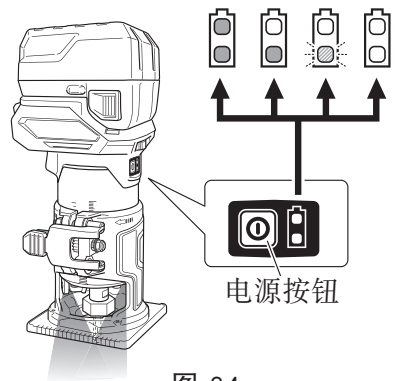


图 34

## 操作注意事项

连续工作后，机器需要静止一段时间

- (1) 电动工具内装有温度保护电路以保护电动机。

长时间连续作业可能会导致机器温度升高、触发温度保护电路并自动停止作业。

在此情况下，请在电动工具冷却后再继续使用。

- (2) 请在长时间连续作业后或更换电池后，使机器静止 15 分钟。如果在更换电池后立刻开始作业，马达和开关等的温度将会升高，结果导致烧毁。

## 维护和检查

### 警告！

检查或维护前，请务必关闭开关并取出电池。

#### 1. 检查钻头

长期使用较钝或损坏的钻头将降低切割效率，且可能导致电动机过载。查出钻头有磨损时，请立即更换新钻头。

### 注意！

若使用较钝的钻头作业，则切割时产生的反作用力会增加。请避免使用未经维修的较钝钻头。

#### 2. 检查螺丝

定期检查所有螺丝，确保螺丝已充分拧紧。如果螺丝松动，请立即重新拧紧。

### 警告！

使用螺丝松动的木工修边机十分危险。

#### 3. 电动机的维护

电动机绕线是电动工具的“心脏部”应仔细检查有无损伤，是否被油液或水沾湿。

#### 4. 查看灰尘

### 警告！

为防止吸入灰尘或刺激眼睛，使用气枪清洁时，请佩戴好安全护目镜和防尘面罩。

使用气枪或其他类似工具清除粘附在机身上的材料、碎屑等（尤其是图 35 所示部位），并用柔软的干布或蘸有肥皂水的布擦拭。

请勿使用漂白剂、氯、汽油或稀释剂，因为可能会损坏塑料。（图 35）

#### 5. 检查端子（工具和电池）

确保端子上没有堆积削屑和灰尘。

在操作前、操作时和操作后需要时常检查。

### 注意！

请清除端子上的削屑或灰尘。

否则可能导致故障。

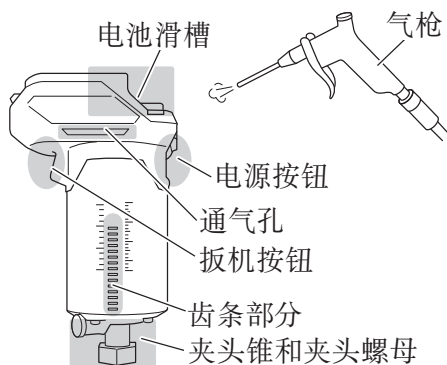


图 35

### 6. 电力耗尽的电池的处理方法

#### 警告！

请勿将电力耗尽的电池丢弃。如果焚烧电池，可能会引起爆炸。该电池可回收利用。根据各国家和地区的法令法规，将电力耗尽的电池丢弃到城市垃圾中属于违法行为。请向当地的固体废弃物负责人员咨询具体回收事宜或妥善的处理方法。

### 7. 收藏

存放在 40 度以下儿童够不到的地方。

#### 注：

存放锂离子电池

存放锂离子电池前，确保其已充满电。

电池在低电量的状态下长时间存放（3 个月或更长），可能会导致电池性能劣化，使用时间明显减少或无法进行充电。

但是，即使是使用时间明显减少的电池，通过反复充电和使用 2 ~ 5 次，有时也可恢复使用时间。

若反复充电和使用后电池的使用时间仍非常短，请认作为电池已达到了使用寿命并更换新的电池。

### 8. 服务与维修

所有优质电动工具都将因正常使用磨损进行维修或更换部件。为确保维修或更换的部件仅为 HiKOKI 授权的更换部件，所有维修及修理工作仅限由 HiKOKI 授权的维修中心进行。

#### 注意！

在操作和维修电动工具时，必须遵守贵国制定的安全的有关规则 and 标准。

#### 关于 HiKOKI 牌无线电动工具的重要通知：

请确保始终使用我们指定的正版电池。如果使用我们指定以外的电池，或对电池进行拆卸和改动（例如拆卸和更换电池组件或其他内部部件），那么我们无法保证我们无线电动工具的安全性和使用性能。

## 故障排除

## 警告！

- 为避免意外启动造成人身伤害，在进行任何调整之前，请关闭开关并从电源上拔下插头或从主体中取出电池。
- 所有电气或机械维修仅可由有资格的维修技术人员进行。联系 HiKOKI 授权服务中心。

## 1. 电动工具

现象	可能的原因	解决办法
工具不运转	电池电量耗尽	给电池充电。
	电池没装好。	将电池推入，直至听到咔嗒声为止。
	电源断开。	按电源按钮打开电源。
工具突然停下来	工具负载过重	解决导致负载过重的问题。 在操作过程中，减轻所施加的压力。
	电池或工具过热	使工具和电池彻底冷却。
	剩余电量不足	为电池充电。
锯割效果不佳	钻头磨损或缺齿。	更换新钻头。
	弹性夹头松动。	拧紧弹性夹头。
剩余电池电量指示灯正在闪烁	表示电池剩余电量很低。	尽快进行充电。
本机的剩余电池电量指示灯与电池的剩余电量指示灯不符	—	请参阅电池上的指示灯。
无法安装电池	请尝试安装该工具指定的其他正版电池。	请安装多伏电池或 BSL18xx 系列电池。



# 中文

## 2. 充电器

现象	可能的原因	解决办法
充电指示灯快速闪烁紫色，电池未开始充电。	电池未完全插入。	请紧紧插入电池。
	电池端部或电池的连接处有异物。	将异物清除。
充电指示灯闪烁红色，电池未开始充电。	电池未完全插入。	请紧紧插入电池。
	电池过热。	如果继续放置，电池将在温度降低后自动开始充电，但此种情况可能会缩短电池使用寿命。建议将电池放置在通风良好的位置，在充电前避免阳光直射。
即使电池完全充电，电池的使用寿命也会逐渐缩短。	电池的使用寿命已耗尽。	请更换新电池。
电池的充电时间较长。	电池、充电器或周围环境的温度过低。	请在室内或温暖的环境中充电。
	充电器的排气孔堵塞，导致其内部部件过热。	请勿堵塞排气孔。
	冷却扇未运转。	请联系 HiKOKI 授权服务中心进行维修。
USB 电源灯熄灭，USB 设备停止充电。	电池剩余电量低。	用电量充足电池替换它。
		将充电器的电源插头插入电插座中。
即使 USB 设备充电完毕，USB 电源灯也不熄灭。	USB 电源灯点亮呈绿色，提示可进行 USB 充电。	这种情况不属于故障。
不清楚 USB 设备的充电状态如何或者是否充电完毕。	即使充电完毕，USB 电源灯也不熄灭。	检查正在充电的 USB 设备以确定其充电状态。

现象	可能的原因	解决办法
USB 设备在中途暂停充电。	使用电池作为电源对 USB 设备进行充电时，充电器插入电插座。	这种情况不属于故障。充电器与电源间存在差异时，USB 将暂停充电约 5 秒钟。
	使用电源插座作为电源对 USB 设备进行充电时，电池插入充电器。	
电池和 USB 设备同时充电时，USB 设备将在中途暂停充电。	电池已完全充电。	这种情况不属于故障。检查电池是否已充电完成时，充电器将暂停 USB 充电约 5 秒钟。
电池和 USB 设备同时充电时，USB 设备将无法开始充电。	电池剩余电量已不足。	这种情况不属于故障。电池电量达到一定程度时，USB 将自动开始充电。

## 选择附件

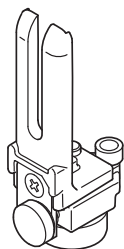
根据特定作业选择适合的附件。  
有关详细信息请联系 HiKOKI 授权服务中心。



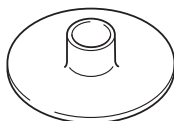
产品编号：377117  
夹头锥 6mm



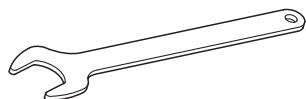
产品编号：377133  
夹头锥 8mm



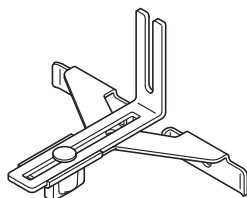
产品编号：377127



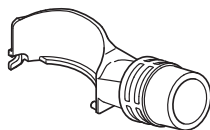
产品编号：377129



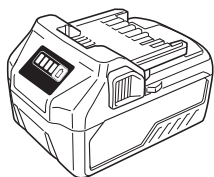
产品编号：377128



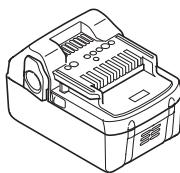
产品编号：377126



产品编号：377131

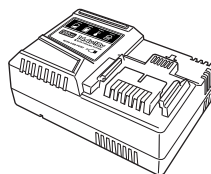


BSL36A18

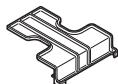


18V (Li-ion)

电池



UC18YSL3  
(14.4V - 18V)  
Charger



产品编号：329897  
电池盖

## CONTENTS

GENERAL POWER TOOL SAFETY WARNINGS .....	33
CORDLESS TRIMMER SAFETY WARNINGS .....	36
ADDITIONAL SAFETY WARNINGS .....	37
CAUTION ON LITHIUM-ION BATTERY .....	38
REGARDING LITHIUM-ION BATTERY TRANSPORTATION .....	40
USB DEVICE CONNECTION PRECAUTIONS .....	40
SYMBOLS .....	40
NAME OF PARTS .....	41
SPECIFICATIONS .....	42
STANDARD ACCESSORIES .....	43
APPLICATIONS .....	43
BATTERY REMOVAL/INSTALLATION .....	44
CHARGING .....	44
HOW TO RECHARGE USB DEVICE .....	47
BEFORE USE .....	48
INSTALLING AND REMOVING BITS .....	48
PRIOR TO OPERATION .....	49
OPERATION .....	54
OPERATIONAL CAUTIONS .....	59
MAINTENANCE AND INSPECTION .....	60
TROUBLESHOOTING GUIDE .....	62
SELECTING ACCESSORIES .....	65

## GENERAL POWER TOOL SAFETY WARNINGS

### WARNING

**Read all safety warnings and all instructions.**

*Failure to follow the warnings and instructions may result in electric shock, fire and/or serious injury.*

**Save all warnings and instructions for future reference.**

*The term “power tool” in the warnings refers to your mains-operated (corded) power tool or battery-operated (cordless) power tool.*

#### 1) Work area safety

##### a) **Keep work area clean and well lit.**

*Cluttered or dark areas invite accidents.*

##### b) **Do not operate power tools in explosive atmospheres, such as in the presence of flammable liquids, gases or dust.**

*Power tools create sparks which may ignite the dust or fumes.*

##### c) **Keep children and bystanders away while operating a power tool.**

*Distractions can cause you to lose control.*

# English

## 2) Electrical safety

- a) **Power tool plugs must match the outlet.**  
**Never modify the plug in any way.**  
**Do not use any adapter plugs with earthed (grounded) power tools.**  
*Unmodified plugs and matching outlets will reduce risk of electric shock.*
- b) **Avoid body contact with earthed or grounded surfaces, such as pipes, radiators, ranges and refrigerators.**  
*There is an increased risk of electric shock if your body is earthed or grounded.*
- c) **Do not expose power tools to rain or wet conditions.**  
*Water entering a power tool will increase the risk of electric shock.*
- d) **Do not abuse the cord. Never use the cord for carrying, pulling or unplugging the power tool.**  
**Keep cord away from heat, oil, sharp edges or moving parts.**  
*Damaged or entangled cords increase the risk of electric shock.*
- e) **When operating a power tool outdoors, use an extension cord suitable for outdoor use.**  
*Use of a cord suitable for outdoor use reduces the risk of electric shock.*
- f) **If operating a power tool in a damp location is unavoidable, use a residual current device (RCD) protected supply.**  
*Use of an RCD reduces the risk of electric shock.*

## 3) Personal safety

- a) **Stay alert, watch what you are doing and use common sense when operating a power tool.**  
**Do not use a power tool while you are tired or under the influence of drugs, alcohol or medication.**  
*A moment of inattention while operating power tools may result in serious personal injury.*
- b) **Use personal protective equipment. Always wear eye protection.**  
*Protective equipment such as dust mask, non-skid safety shoes, hard hat, or hearing protection used for appropriate conditions will reduce personal injuries.*
- c) **Prevent unintentional starting. Ensure the switch is in the off position before connecting to power source and/or battery pack, picking up or carrying the tool.**  
*Carrying power tools with your finger on the switch or energising power tools that have the switch on invites accidents.*
- d) **Remove any adjusting key or wrench before turning the power tool on.**  
*A wrench or a key left attached to a rotating part of the power tool may result in personal injury.*
- e) **Do not overreach. Keep proper footing and balance at all times.**  
*This enables better control of the power tool in unexpected situations.*
- f) **Dress properly. Do not wear loose clothing or jewellery. Keep your hair, clothing and gloves away from moving parts.**  
*Loose clothes, jewellery or long hair can be caught in moving parts.*

- g) **If devices are provided for the connection of dust extraction and collection facilities, ensure these are connected and properly used.**

*Use of dust collection can reduce dust-related hazards.*

4) **Power tool use and care**

- a) **Do not force the power tool. Use the correct power tool for your application.**

*The correct power tool will do the job better and safer at the rate for which it was designed.*

- b) **Do not use the power tool if the switch does not turn it on and off.**

*Any power tool that cannot be controlled with the switch is dangerous and must be repaired.*

- c) **Disconnect the plug from the power source and/or the battery pack from the power tool before making any adjustments, changing accessories, or storing power tools.**

*Such preventive safety measures reduce the risk of starting the power tool accidentally.*

- d) **Store idle power tools out of the reach of children and do not allow persons unfamiliar with the power tool or these instructions to operate the power tool.**

*Power tools are dangerous in the hands of untrained users.*

- e) **Maintain power tools. Check for misalignment or binding of moving parts, breakage of parts and any other condition that may affect the power tool's operation.**

**If damaged, have the power tool repaired before use.**

*Many accidents are caused by poorly maintained power tools.*

- f) **Keep cutting tools sharp and clean.**

*Properly maintained cutting tools with sharp cutting edges are less likely to bind and are easier to control.*

- g) **Use the power tool, accessories and tool bits etc. in accordance with these instructions, taking into account the working conditions and the work to be performed.**

*Use of the power tool for operations different from those intended could result in a hazardous situation.*

5) **Battery tool use and care**

- a) **Recharge only with the charger specified by the manufacturer.**

*A charger that is suitable for one type of battery pack may create a risk of fire when used with another battery pack.*

- b) **Use power tools only with specifically designated battery packs.**

*Use of any other battery packs may create a risk of injury and fire.*

- c) **When battery pack is not in use, keep it away from other metal objects, like paper clips, coins, keys, nails, screws or other small metal objects, that can make a connection from one terminal to another.**

*Shorting the battery terminals together may cause burns or a fire.*

## English

- d) **Under abusive conditions, liquid may be ejected from the battery; avoid contact. If contact accidentally occurs, flush with water. If liquid contacts eyes, additionally seek medical help.**

*Liquid ejected from the battery may cause irritation or burns.*

### 6) Service

- a) **Have your power tool serviced by a qualified repair person using only identical replacement parts.**

*This will ensure that the safety of the power tool is maintained.*

## CAUTION

Keep children and infirm persons away.

When not in use, tools should be stored out of reach of children and infirm persons.

## CORDLESS TRIMMER SAFETY WARNINGS

- 1. Hold the power tool by insulated gripping surfaces only, when performing an operation where the cutting tool may contact hidden wiring.**  
Contact with a "live" wire will also make exposed metal parts of the power tool "live" and could give the operator an electric shock.
- 2. Use clamps or another practical way to secure and support the workpiece to a stable platform.**  
Holding the work by your hand or against the body leaves it unstable and may lead to loss of control.
- 3. Always wear ear protectors when using the tool for extended periods.**  
Prolonged exposure to high intensity noise can cause hearing loss.
- 4. Handle the bits very carefully.**
- 5. Check the bit carefully for cracks or damage before operation. Replace cracked or damaged bit immediately.**
- 6. Avoid cutting nails. Inspect for and remove all nails from the workpiece before operation.**
- 7. Make sure to securely hold the tool during operation. Failure to do so can result in accidents or injuries. (Fig. 31 on page 57)**
- 8. Keep hands away from rotating parts.**
- 9. Make sure the bit is not contacting the workpiece before the switch is turned on.**
- 10. Before using the tool on an actual workpiece, let it run for a while. Watch for vibration or wobbling that could indicate improperly installed bit.**
- 11. Be careful of the bit rotating direction and the feed direction.**
- 12. Do not leave the tool running. Operate the tool only when hand-held.**
- 13. Always switch off and wait for the bit to come to a complete stop before removing the tool from workpiece.**
- 14. Do not touch the bit and shaft, collet nut, collet cone immediately after operation: it may be extremely hot and could burn your skin.**



15. **After changing the bits or making any adjustments, make sure the collet chuck and any other adjustment devices are securely tightened.**  
Loose adjustment device can unexpectedly shift, causing loss of control, loose rotating components will be violently thrown.
16. **Always wear eye protection.**
17. Because the cordless power tool operates by battery power, be aware of the fact that it can begin to operate at any time.
18. Use bits of the correct shank diameter suitable for the speed of the tool.
19. When operating the tool, do not wear work gloves as such cloth wear can get caught in the tool.

## ADDITIONAL SAFETY WARNINGS

1. **Always charge the battery at a temperature of 0–40°C.**  
A temperature of less than 0°C will result in over charging which is dangerous. The battery cannot be charged at a temperature greater than 40°C.  
The most suitable temperature for charging is that of 20–25°C.
2. **Do not use the charger continuously.**  
When one charging is completed, leave the charger for about 15 minutes before the next charging of battery.
3. **Do not allow foreign matter to enter the hole for connecting the rechargeable battery.**
4. **Never disassemble the rechargeable battery and charger.**
5. **Never short-circuit the rechargeable battery.** Shortcircuiting the battery will cause a great electric current and overheat. It results in burn or damage to the battery.
6. **Do not dispose of the battery in fire.** If the battery is burnt, it may explode.
7. **Bring the battery to the shop from which it was purchased as soon as the post-charging battery life becomes too short for practical use.** Do not dispose of the exhausted battery.
8. **Do not insert object into the air ventilation slots of the charger.** Inserting metal objects or inflammables into the charger air ventilation slots will result in electrical shock hazard or damaged charger.
9. **When using this unit continuously, the unit may overheat, leading to damage in the motor and switch.** Therefore, whenever the housing becomes hot, give the tool a break for a while.
10. **Make sure that the battery is installed firmly.** If it is at all loose it could come off and cause an accident.
11. **Do not use the product if the tool or the battery terminals (battery mount) are deformed.**  
Installing the battery could cause a short circuit that could result in smoke emission or ignition.
12. **Keep the tool's terminals (battery mount) free of swarf and dust.**
  - Prior to use, make sure that swarf and dust have not collected in the area of the terminals.
  - During use, try to avoid swarf or dust on the tool from falling on the battery.

## English

- When suspending operation or after use, do not leave the tool in an area where it may be exposed to falling swarf or dust.  
Doing so could cause a short circuit that could result in smoke emission or ignition.
- 13. Always use the tool and battery at temperatures between -5°C and 40°C.

### CAUTION ON LITHIUM-ION BATTERY

To extend the lifetime, the lithium-ion battery equips with the protection function to stop the output.

In the cases of 1 to 3 described below, when using this product, even if you are pulling the switch, the motor may stop. This is not the trouble but the result of protection function.

1. When the battery power remaining runs out, the motor stops.  
In such case, charge it up immediately.
2. If the tool is overloaded, the motor may stop. In this case, release the switch of tool and eliminate causes of overloading. After that, you can use it again.
3. If the battery is overheated under overload work, the battery power may stop.  
In this case, stop using the battery and let the battery cool. After that, you can use it again.

Furthermore, please heed the following warning and caution.

### WARNING

In order to prevent any battery leakage, heat generation, smoke emission, explosion and ignition beforehand, please be sure to heed the following precautions.

1. Make sure that swarf and dust do not collect on the battery.
  - During work make sure that swarf and dust do not fall on the battery.
  - Make sure that any swarf and dust falling on the power tool during work do not collect on the battery.
  - Do not store an unused battery in a location exposed to swarf and dust.
  - Before storing a battery, remove any swarf and dust that may adhere to it and do not store it together with metal parts (screws, nails, etc.).
2. Do not pierce battery with a sharp object such as a nail, strike with a hammer, step on, throw or subject the battery to severe physical shock.
3. Do not use an apparently damaged or deformed battery.
4. Do not use the battery in reverse polarity.
5. Do not connect directly to an electrical outlets or car cigarette lighter sockets.
6. Do not use the battery for a purpose other than those specified.
7. If the battery charging fails to complete even when a specified recharging time has elapsed, immediately stop further recharging.
8. Do not put or subject the battery to high temperatures or high pressure such as into a microwave oven, dryer, or high pressure container.
9. Keep away from fire immediately when leakage or foul odor are detected.
10. Do not use in a location where strong static electricity generates.

11. If there is battery leakage, foul odor, heat generated, discolored or deformed, or in any way appears abnormal during use, recharging or storage, immediately remove it from the equipment or battery charger, and stop use.
12. Do not immerse the battery or allow any fluids to flow inside. Conductive liquid ingress, such as water, can cause damage resulting in fire or explosion. Store your battery in a cool, dry place, away from combustible and flammable items. Corrosive gas atmospheres must be avoided.

## CAUTION

1. If liquid leaking from the battery gets into your eyes, do not rub your eyes and wash them well with fresh clean water such as tap water and contact a doctor immediately.  
If left untreated, the liquid may cause eye-problems.
2. If liquid leaks onto your skin or clothes, wash well with clean water such as tap water immediately.  
There is a possibility that this can cause skin irritation.
3. If you find rust, foul odor, overheating, discolor, deformation, and/or other irregularities when using the battery for the first time, do not use and return it to your supplier or vendor.

## WARNING

If an electrically conductive foreign object enters the terminals of the lithium ion battery, a short-circuit may occur resulting in the risk of fire. Please observe the following matters when storing the battery.

- Do not place electrically conductive cuttings, nails, steel wire, copper wire or other wire in the storage case.
- Either install the battery in the power tool or store by securely pressing into the battery cover until the ventilation holes are concealed to prevent short-circuits (Fig. 1).

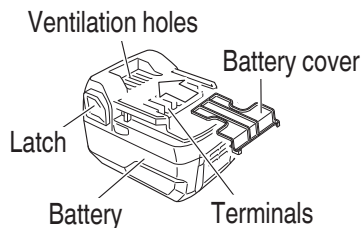


Fig. 1

## REGARDING LITHIUM-ION BATTERY TRANSPORTATION

When transporting a lithium-ion battery, please observe the following precautions.

### WARNING

Notify the transporting company that a package contains a lithium-ion battery, inform the company of its power output and follow the instructions of the transportation company when arranging transport.

- Lithium-ion batteries that exceed a power output of 100 Wh are considered to be in the freight classification of Dangerous Goods and will require special application procedures.
- For transportation abroad, you must comply with international law and the rules and regulations of the destination country.

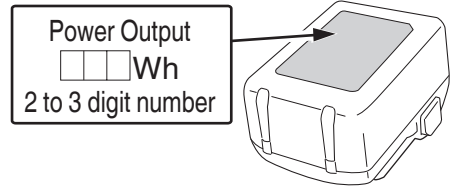


Fig. 2

## USB DEVICE CONNECTION PRECAUTIONS




When an unexpected problem occurs, the data in a USB device connected to this product may be corrupted or lost. Always make sure to back up any data contained in the USB device prior to use with this product.

Please be aware that our company accepts absolutely no responsibility for any data stored in a USB device that is corrupted or lost, nor for any damage that may occur to a connected device.

## SYMBOLS

### WARNING

The following show symbols used for the machine. Be sure that you understand their meaning before use.

	To reduce the risk of injury, user must read instruction manual.	$n_0$	No-load speed
	Direct current	/min	Oscillation per minute
V	Rated voltage		Warning

## NAME OF PARTS

1. Cordless trimmer (M1808DA)

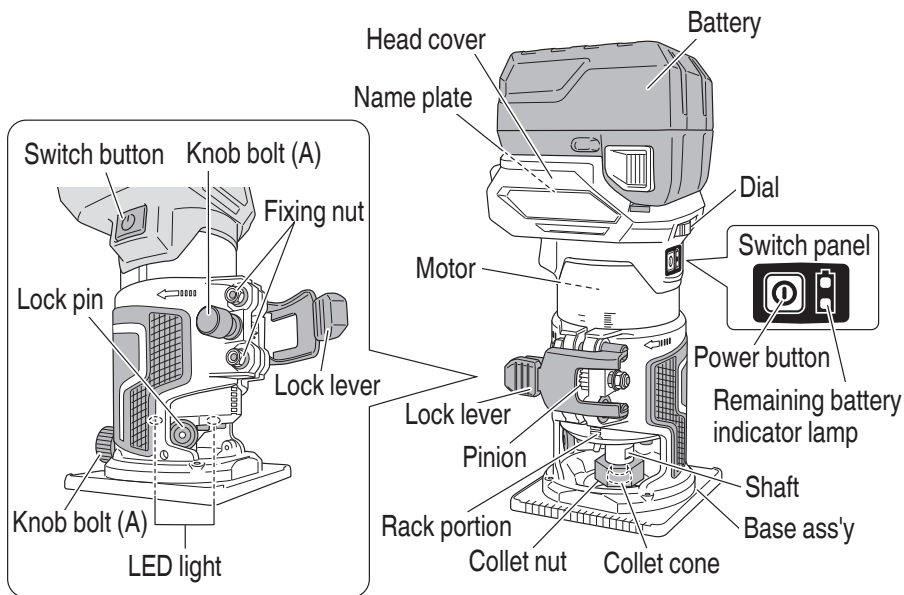
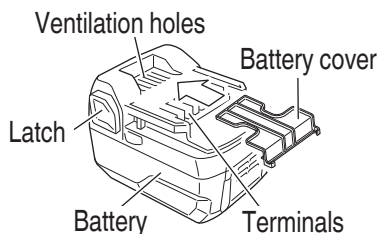


Fig. 3

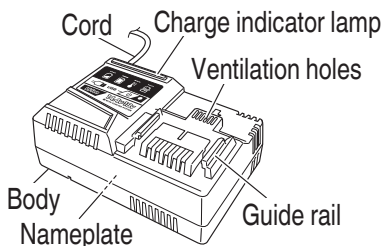
2. Battery  
(optional accessories...sold separately)



<BSL1850C>

Fig. 4

3. Battery Charger  
(optional accessories...sold separately)



<UC18YSL3>

Fig. 5

## SPECIFICATIONS

### POWER TOOL

Model	M1808DA
Voltage	18 V
Collet chuck capacity	6.35 mm
No-load speed	10000–30000 /min
Battery	BSL1850C: Li-ion 18 V (5.0 Ah, 5 cells)
Weight	1.7 kg (BSL1850C and dust collector attached)

### NOTE

Available bit: Straight bits, Flush trimming bits, Chamfering bits, Round-over bits, Rabbeting bits, Dovetail bits.


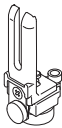




### Charger (Sold separately)

Model	UC18YSL3
Charging voltage	14.4–18 V
Weight	0.6 kg

## STANDARD ACCESSORIES

In addition to the main unit (1 unit), the package contains the accessories listed in the below.

Table 1

		M1808DA (NN)
1/4" Collet cone		1
Trimmer guide		1
Straight guide		1
Template guide		1
Dust collector set		1
23 mm Wrench		1

## APPLICATIONS

- Woodworking jobs centered on grooving and beveling.  
For example, grooving beveling, cutting, copying, engraving, shape cutting, combinations and others.

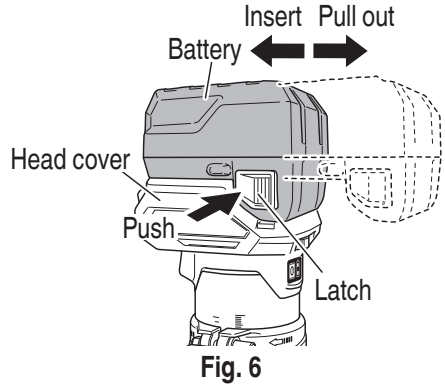
## BATTERY REMOVAL/INSTALLATION

1. **Battery removal**  
Hold the handle tightly and push the battery latches (2 pcs.) to remove the battery (Fig. 6).

### CAUTION

Never short-circuit the battery.

2. **Battery installation**  
Insert the battery while observing its polarities (Fig. 6).



## CHARGING

Before using the power tool, charge the battery as follows.

1. **Connect the charger's power cord to the receptacle.**  
When connecting the plug of the charger to a receptacle, the pilot lamp will blink in red (At 1- second intervals).
  2. **Insert the battery into the charger.**  
Firmly insert the battery into the charger as shown in Fig. 7.
  3. **Charging**  
When inserting a battery in the charger, the charge indicator lamp will blink in blue.  
When the battery becomes fully recharged, the charge indicator lamp will light up in green. (See Table 2)
- (1) Charge indicator lamp indication  
The indications of the charge indicator lamp will be as shown in Table 2, according to the condition of the charger or the rechargeable battery.

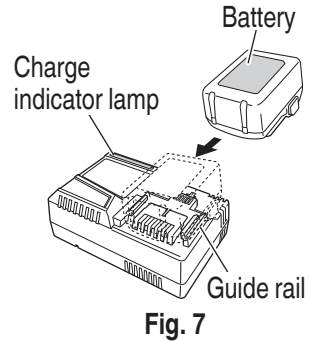











Table 2

Indications of the charge indicator lamp				
Charge indicator lamp (RED / BLUE / GREEN / PURPLE)	Before charging	Blinks (RED)	Lights for 0.5 seconds. Does not light for 0.5 seconds. (off for 0.5 seconds) 	Plugged into power source
	While charging	Blinks (BLUE)	Lights for 0.5 seconds. Does not light for 1 second. (off for 1 second) 	Battery capacity at less than 50%
		Blinks (BLUE)	Lights for 1 second. Does not light for 0.5 seconds. (off for 0.5 seconds) 	Battery capacity at less than 80%
		Lights (BLUE)	Lights continuously 	Battery capacity at more than 80%
	Charging complete	Lights (GREEN)	Lights continuously  (Continuous buzzer sound: about 6 seconds)	
	Overheat standby	Blinks (RED)	Lights for 0.3 seconds. Does not light for 0.3 seconds. (off for 0.3 seconds) 	Battery overheated. Unable to charge. (Charging will commence when battery cools)
	Charging impossible	Flickers (PURPLE)	Lights for 0.1 seconds. Does not light for 0.1 seconds. (off for 0.1 seconds)  (Intermittent buzzer sound: about 2 seconds)	Malfunction in the battery or the charger

# English

- (2) Regarding the temperatures and charging time of the rechargeable battery  
The temperatures and charging time will become as shown in **Table 3**.

**Table 3**

Charger		UC18YSL3					
Battery	Type of battery	Li-ion					
	Temperatures at which the battery can be recharged	0°C–50°C					
	Charging voltage	V	14.4		18		
	Charging time, approx. (At 20°C)	min	BSL14xx series		BSL18xx series		Multi volt series
			(4 cells)	(8 cells)	(5 cells)	(10 cells)	(10 cells)
		BSL1415S: 15 BSL1415 : 15 BSL1415X: 15 BSL1420 : 20 BSL1425 : 25 BSL1430C: 30	BSL1430 : 20 BSL1440 : 26 BSL1450 : 32 BSL1460 : 38	BSL1815S: 15 BSL1815 : 15 BSL1815X: 15 BSL1820 : 20 BSL1825 : 25 BSL1830C: 30 BSL1850C: 32	BSL1830 : 20 BSL1840 : 26 BSL1850 : 32 BSL1860 : 38	BSL36A18: 32 BSL36B18: 52 BSL36C18: 20	
USB	Charging voltage	V	5				
	Charging current	A	2				

## NOTE

The recharging time may vary according to the ambient temperature and power source voltage.

4. Disconnect the charger's power cord from the receptacle.
5. Hold the charger firmly and pull out the battery.

## NOTE

Be sure to pull out the battery from the charger after use, and then keep it.

### Regarding electric discharge in case of new batteries, etc.

As the internal chemical substance of new batteries and batteries that have not been used for an extended period is not activated, the electric discharge might be low when using them the first and second time. This is a temporary phenomenon, and normal time required for recharging will be restored by recharging the batteries 2–3 times.

### How to make the batteries perform longer.

- (1) Recharge the batteries before they become completely exhausted.  
When you feel that the power of the tool becomes weaker, stop using the tool and recharge its battery. If you continue to use the tool and exhaust the electric current, the battery may be damaged and its life will become shorter.
- (2) Avoid recharging at high temperatures.  
A rechargeable battery will be hot immediately after use. If such a battery is recharged immediately after use, its internal chemical substance will deteriorate, and the battery life will be shortened. Leave the battery and recharge it after it has cooled for a while.

### CAUTION

- **If the battery is charged while it is heated because it has been left for a long time in a location subject to direct sunlight or because the battery has just been used, the charge indicator lamp of the charger lights for 0.3 seconds, does not light for 0.3 seconds (off for 0.3 seconds). In such a case, first let the battery cool, then start charging.**
- **When the charge indicator lamp flickers (at 0.2-second intervals), check for and take out any foreign objects in the charger's battery connector. If there are no foreign objects, it is probable that the battery or charger is malfunctioning. Take it to your authorized Service Center.**

## HOW TO RECHARGE USB DEVICE

### WARNING

- **Prior to use, check the connecting USB cable for any defect or damage. Using a defective or damaged USB cable can cause smoke emission or ignition.**
- **When the product is not being used, cover the USB port with the rubber cover. Buildup of dust etc. in the USB port can cause smoke emission or ignition.**

### NOTE

- There may be an occasional pause during USB recharging.
- When a USB device is not being charged, remove the USB device from the charger. Failure to do so may not only reduce the battery life of a USB device, but may also result in unexpected accidents.
- It may not be possible to charge some USB devices, depending on the type of device.
- (1) Select a charging method  
Depending on the charge method selected, either the battery is inserted into the charger or the power cord is plugged into an outlet.
- Charging a USB device from a electrical outlet. (Fig. 8-a)
- Charging a USB device and battery from a electrical outlet. (Fig. 8-b)

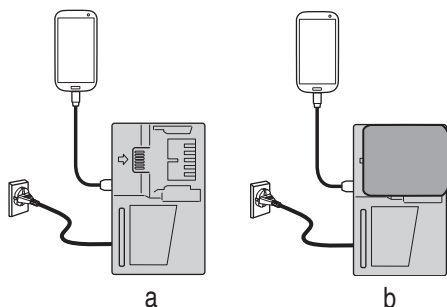


Fig. 8

## English

- (2) Connect the USB cable. (**Fig. 9**)  
Pull back the rubber cover and firmly plug in a commercially available USB cable (appropriate to the device being charged) into the USB port.
- (3) When charging is completed
  - To verify charge status, check the USB device.
  - Unplug the power cord from the electrical outlet. (**Fig. 10**)
  - Place the rubber cover over the USB port.

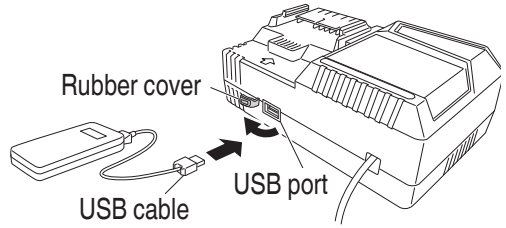


Fig. 9

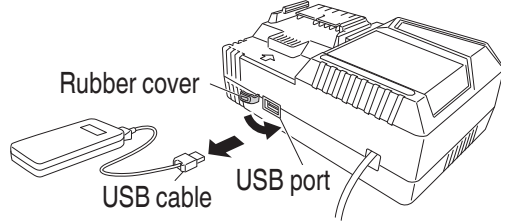


Fig. 10

## BEFORE USE

### WARNING

To avoid a serious accident, press the power button located on the switch panel to turn the power OFF, and pull out the battery.

Check the work area environment

Check the work area to make sure that it is clear of debris and clutter.

Clear the area of unnecessary personnel. Ensure that lighting and ventilation is adequate.

## INSTALLING AND REMOVING BITS

### WARNING

To avoid a serious accident, press the power button located on the switch panel to turn the power OFF, and pull out the battery.

Use the included 23 mm wrench to tighten the collet nut.

Use of tools other than the included can result in over or under-tightening which may cause injury.

1. Installation using the lock pin
  - (1) Remove the base ass'y from the body.
  - (2) Deeply inset the bit into the collet cone hole. (The distance is 15 mm or more from side of collet nut.)
  - (3) With the bit inserted and pressing the lock pin holding the shaft, use the 23 mm wrench to firmly tighten the collet nut in a clockwise direction (viewed from under the tool). (**Fig. 11**)

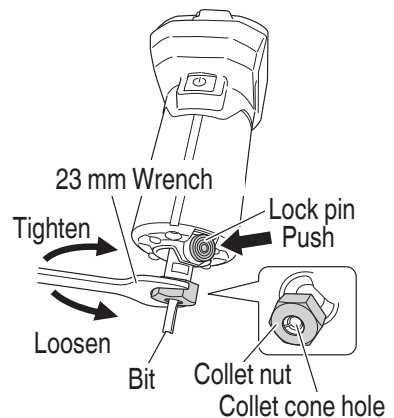
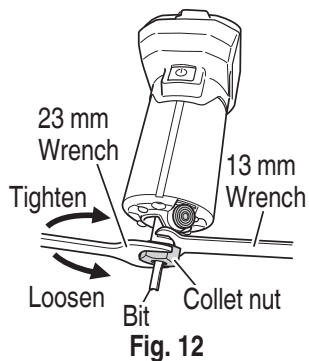


Fig. 11

- (4) Fit the removed base ass'y to the rack provided on the body's outer housing after adjusting the pinion of the base ass'y thereto. Then tilt the lock lever towards the fix side, and fix the base ass'y securely.

When removing the bits, do so by following the steps for installing bits in reverse order.

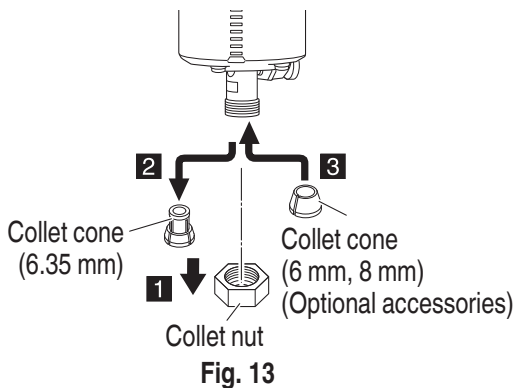
2. Install without using the lock pin
  - (1) Remove the base ass'y from the body.
  - (2) Deeply inset the bit into the collet cone hole. (The distance is 15 mm or more from side of collet nut.)
  - (3) Use a 13 mm Wrench to secure the shaft, and securely tighten the collet nut with the included wrench. (**Fig. 12**)
  - (4) Fit the removed base assembly to the rack provided on the body's outer housing after adjusting the pinion of the base assembly thereto. Then tilt the lock lever towards the fix side, and fix the base ass'y securely.



When removing the bits, do so by following the steps for installing bits in reverse order.

## NOTE

- Ensure that the collet nut is firmly tightened after inserting a bit. The collet cone may become deformed if the collet cone is tightened without a bit set in place.
- Ensure that the lock pin is not inserted into the shaft after tightening the collet cone. Failure to do so will result in damage to the lock pin and shaft.
- Use only trimmer bits of which the maximum speed, as indicated on the bit, does not exceed the maximum speed of the trimmer.



3. Exchanging the collet cone
  - (1) Securing the shaft, remove the collet nut, and exchange the collet cone.
  - (2) Attach the nut, insert the bit, and tighten the nut. (**Fig. 13**)

## PRIOR TO OPERATION

### WARNING

**To avoid a serious accident, press the power button located on the switch panel to turn the power OFF, and pull out the battery.**

1. Installation direction of base ass'y  
The switch position can be changed according to preference by reversing the installation direction of the base ass'y.

# English

- (1) Tilt the lock lever towards the remove side, and remove the base ass'y from the body. (Fig. 14-a)
- (2) Rotate 180 degrees, and place back in the base ass'y, then tilt the lock lever towards the fix side. (Fig. 14-b)

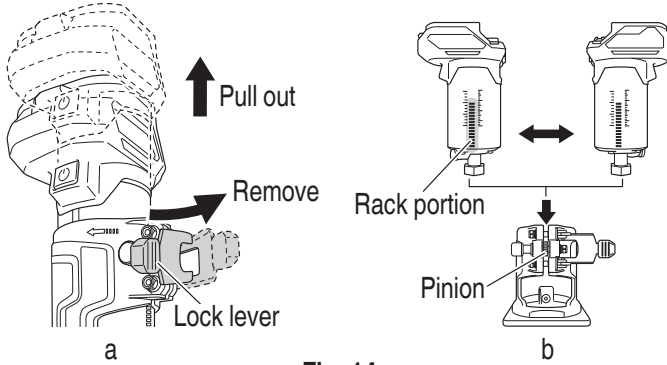


Fig. 14

## 2. Fix strength adjustment method

If there is a decline in the fix strength, adjust as follows.

Tilt the lock lever towards the fixed side, and tighten a fixing nut (two locations) using the socket wrench (8 mm). (Fig. 15-a)

Fix it so that upper and lower spaces "A" of the base ass'y are equal. (Fig. 15-b)

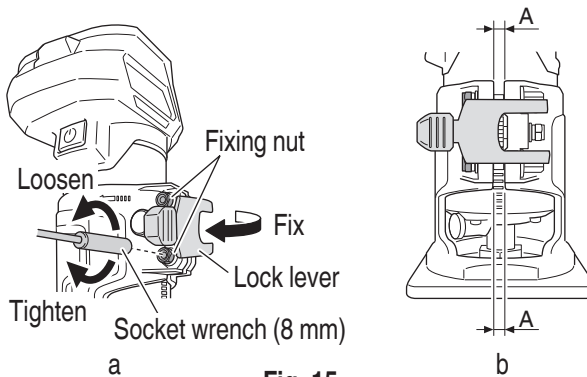


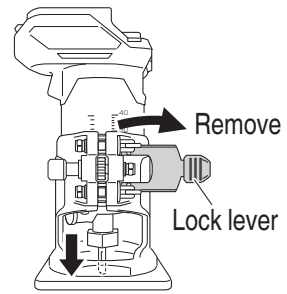
Fig. 15

## NOTE

If the operation load of the lock lever is too heavy, there is too much fixed strength.

As this situation may damage parts, each fixing nut (two locations) should be loosened to readjust the fixed strength.

3. Adjusting depth of cut
  - (1) Place the tool on a flat wood surface.
  - (2) Tilt the lock lever towards the remove side, and turn knob bolt (A) to lower the unit until the tip of the bit lightly touches the material. In this position, the scale on the upper end can be read. (Fig. 16)
  - (3) Turn knob bolt (A) upwards to adjust the scale to the desired cutting depth according in accordance with the position read.



#### NOTE

Please limit the cutting depth of a single cut to under 5 mm.

4. Guiding the trimmer

#### WARNING

**To avoid a serious accident, press the power button located on the switch panel to turn the power OFF, and pull out the battery.**

<Template guide>

It is handy to process with a template a number of materials in one same shape.

(In this case 6.35 × 6.35 mm straight bit is usable.)

- (1) Remove the base ass'y from the main unit.
- (2) Install the template guide in the recessed part of the base ass'y and secure it with two screws. (Fig. 17)

#### NOTE

Tighten the two screws moderately. Optimum tightening torque is 10–15 kg-cm.

- (3) Install the base ass'y in the main unit.

#### CAUTION

**When fit the template guide, the upper part of the template guide must not touch the collet nut.**

When using the trimmer along the interior plane of the template, the dimensions of the finished product will be less than the dimensions of the template by an amount equal to dimension "B", the difference between the radius of the template guide and the radius of the bit. The reverse is true when using the trimmer along the exterior of the template. (Fig. 18)

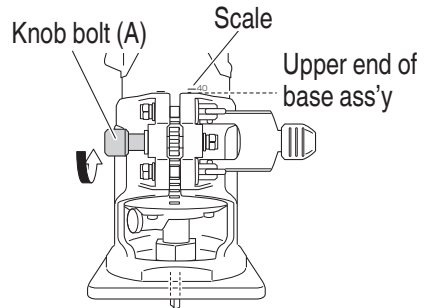
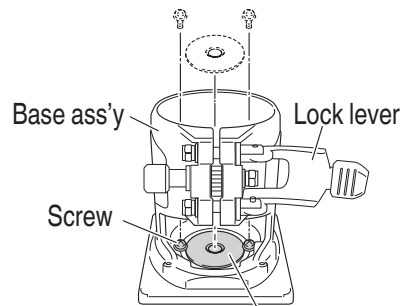


Fig. 16



Template guide

Fig. 17

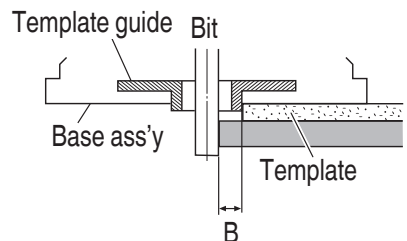
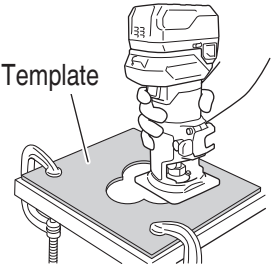


Fig. 18

# English

Secure the template to the workpiece. Feed the trimmer in the manner that the template guide moves along the template as shown in **Fig. 19**.



**Fig. 19**

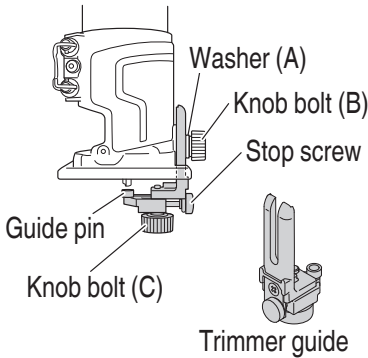
## <Trimmer guide>

The guide is handy when used in processing of materials such as trimming and beveling of plywood.

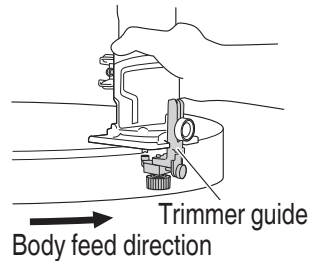
- (1) Fit the trimmer guide on the base ass'y with knob bolt (B).
- (2) Loosen knob bolt (B) to move the trimmer guide up and down.
- (3) Loosen knob bolt (C) and turn the stop screw to move the guide pin. (**Fig. 20**)

After moving the guide pin, tighten knob bolt (C) to secure it.

- (4) As shown in **Fig. 21**, securely attach the bottom of the base ass'y to processed surface of the materials. Feed the trimmer with the guide pin alongside the material.



**Fig. 20**

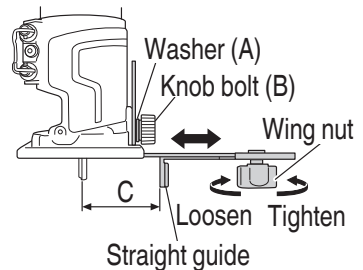
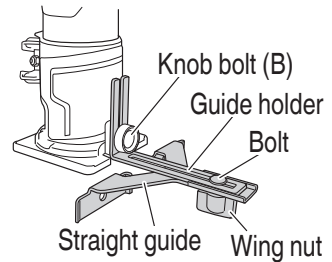


**Fig. 21**

## <Straight guide>

○ It is handy when used for linear processing work such as beveling, grooving and the like.

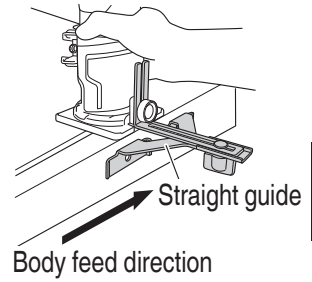
- (1) Fit the straight guide with knob bolt (B) on the base ass'y and fix it.
- (2) Adjust the length "C" from the bit to the surface of straight guide by loosening the wing nut and moving the straight guide as necessary. (**Fig. 22**)



**Fig. 22**



- (3) As shown in **Fig. 23**, securely attach the bottom of the base ass'y to processed surface of the materials. Feed the trimmer while keeping the guide plane on the surface of the materials.



**Fig. 23**

**NOTE**

When using the straight guide, be sure to install it on the right side in the feed direction. This will help to keep it flush with the side of the workpiece.

- By exchanging the straight guide with the guide holder, the tool can be used for circle cutting work.

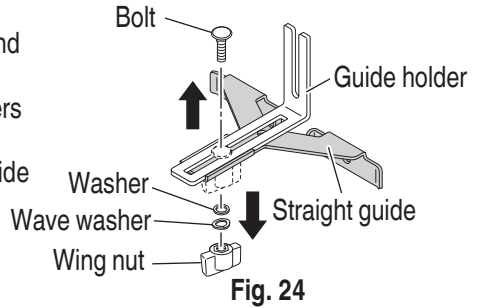
[Processing range (distance from the enter of rotation to the center of the bit)]

Minimum: 84 mm

Maximum: 182 mm

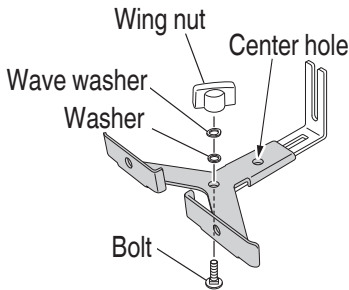
Note that circles measuring 102 to 124 mm and 143 mm to 158 mm cannot be processed.

- (1) Turn wing nut and remove the bolt and washers (2 pieces).
- (2) Reverse the top and bottom of the straight guide and attach it to the guide holder. (**Fig. 24**) Depending on the radius of the circle to be processed, the holes will vary for the wing nut and bolt.

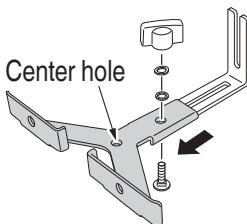


**Fig. 24**

Processing a circle with a radius of 84 to 102 mm



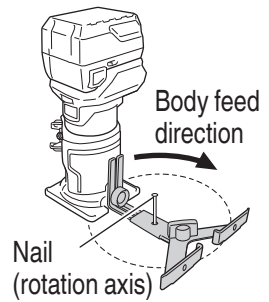
Processing a circle with a radius of 124 to 182 mm



**Fig. 25**

## English

- (3) Installation to the tool is the same as that for straight line processing.
- (4) Align the hole of the straight guide left in the center position of the circle processing, and firmly secure with a nail less than 6 mm in diameter which will act as a rotation axis. Rotate the body towards the right. **(Fig. 26)**

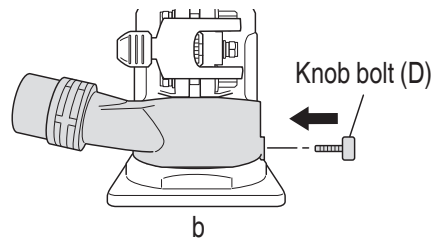
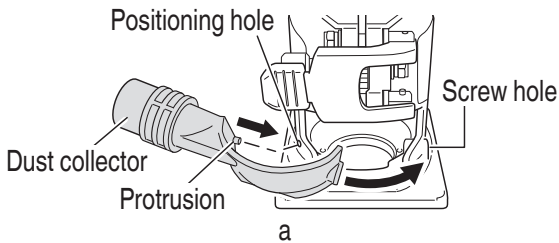


**Fig. 26**

### <Dust Collector Set>

Connect the dust collector set cleaner to collect dust.

- (1) Slot the protrusion on the inside of the dust collector to the positioning hole at the front lower left of the base ass'y, and attach it to cover the front of the base ass'y. **(Fig. 27-a)**
- (2) Using the included knob bolt (D) to secure the dust collector hole to the body's screw hole. **(Fig. 27-b)**



**Fig. 27**

## OPERATION

### WARNING

- To avoid a serious accident, press the power button located on the switch panel to turn the power OFF, and pull out the battery.
- Wear eye protection when operating this tool.
- Keep your hands, face and other body parts away from the bits and any other rotating parts, while operating the tool.

### CAUTION

- To extend the lifetime, the lithium-ion battery equips with the protection function to stop the output. Therefore, if the tool is overloaded, the motor may stop. However, this is not the trouble but the result of protection function. In this case, release the switch of tool and eliminate the causes of overloading.
- Pull out the battery after completing operation.

## 1. Switch operation

The unit will operate when the switch button is pressed after pressing the power button.

(Fig. 28)

See Fig. 29 on page 56 for specifications on button controls.

The remaining battery indicator lamp and LED light will always operate together with the power button.

If the power is ON and the tool is not operated for approximately 10 seconds, the power will be automatically switched OFF and the remaining battery indicator lamp and LED light will also be switched off.

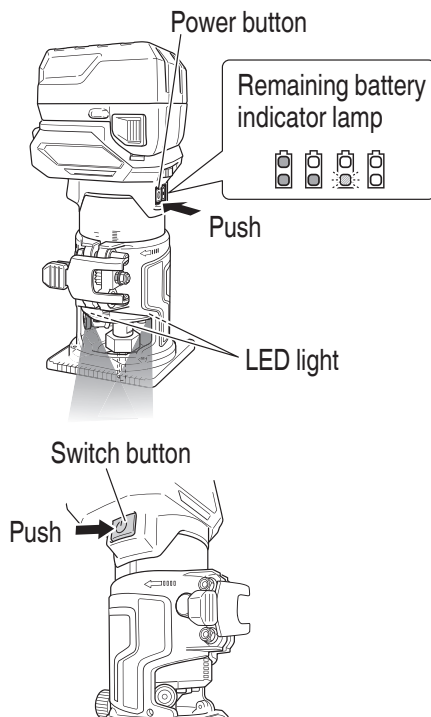


Fig. 28

# English

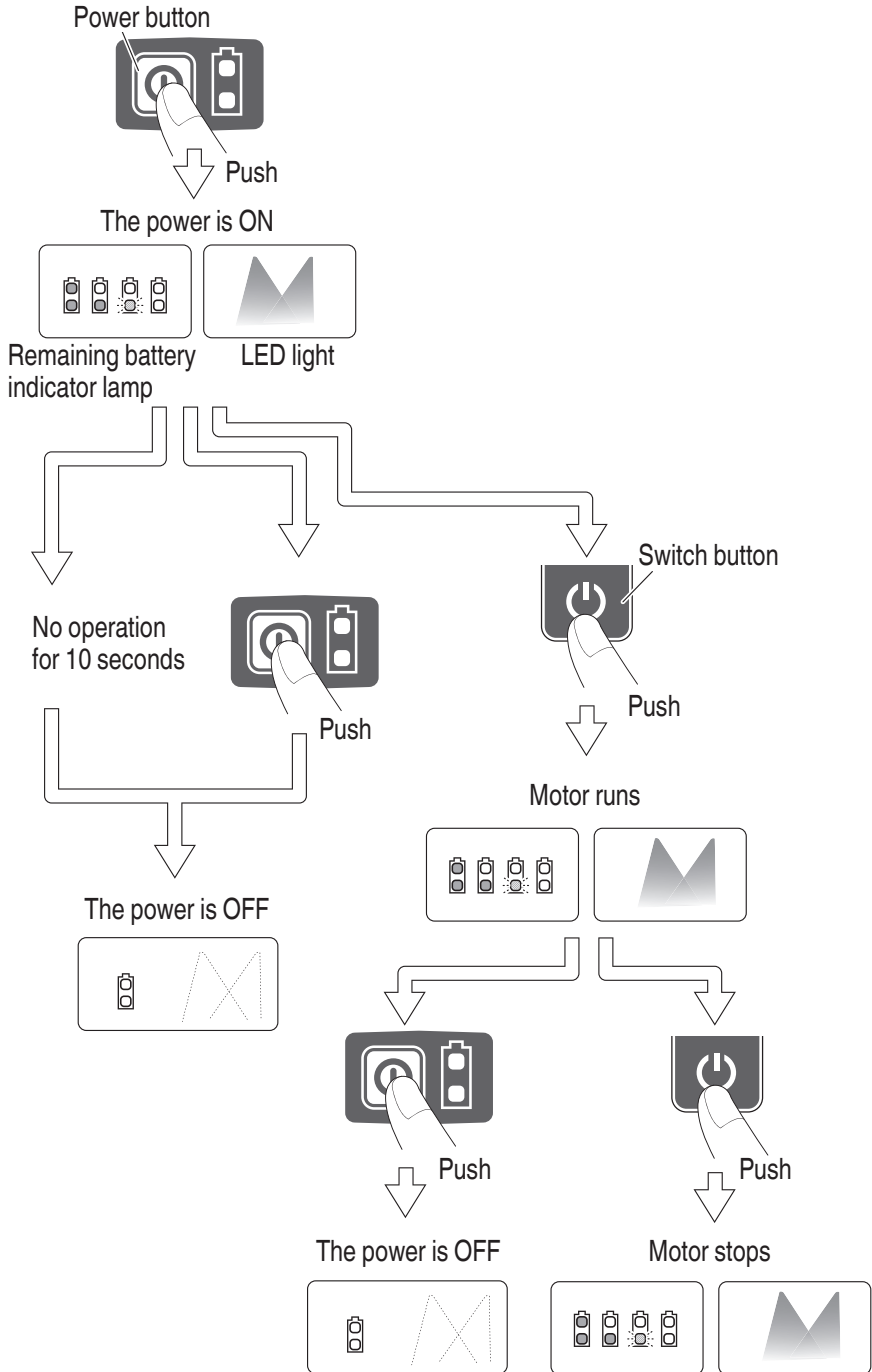


Fig. 29

**CAUTION**

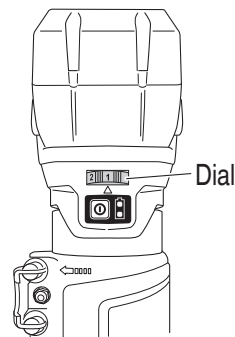
**Do not look directly into the light from the LED lamp. Continuous and direct exposure to the light from the LED lamp can injure your eyes.**

2. Adjusting the rotation speed  
The M1808DA has an electronic control system that allows rotation speed changes. As shown in **Fig. 30**, dial position "1" is for minimum speed, and position "6" for maximum speed.
3. Cutting Operation

**CAUTION**

**When processing the side of a material, make sure that the side to be processed is on the left of the bit in the direction that the material is fed.**

**Placing the side to be processed on the right of the bit goes counter to the bit's revolution and may cause the motor to stop. Too much load in such cases may result in malfunction.**

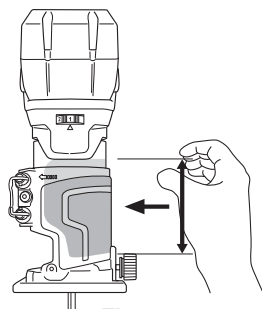
**Fig. 30****NOTE**

- Do not press the lock pin while the motor is rotating. Also, do not switch the tool on while pressing the lock pin.  
Doing so may damage the lock pin and/or shaft as well as result in injury.
- Please limit the cutting depth of a single cut to under 5 mm.
- When cutting a deep groove, repeat the cut 2 or 3 times.  
Deep cutting operations can make the tool difficult to control and may overload the motor, resulting in malfunction.
- Moving the tool forward fast may cause a poor quality of cut, or damage to the bit or motor. Moving the tool forward too slowly may burn and mar the cut.  
The proper feed rate will depend on the bit size, the kind of workpiece and depth of cut. Before beginning the cut on the actual workpiece, it is advisable to make a sample cut on a piece of scrap lumber. This will show exactly how the cut will look as well as enable you to check dimensions.
- Abnormalities and overloads will trigger the overload protector, and stop operation. Remove the load immediately, and turn the power off, then on. The rotation speed should return to normal.

It is recommended that the most appropriate guide be used which is suitable to the type of the work in order to carry out the work exactly without failure.

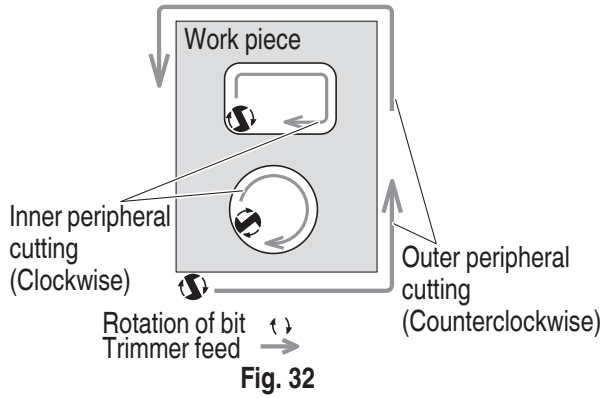
(Refer to "Guiding the trimmer".) The workpieces to be processed should be firmly fixed.

- (1) Keep the bit separated from the workpieces and hold the body firmly before switch is turned on. (**Fig. 31**)

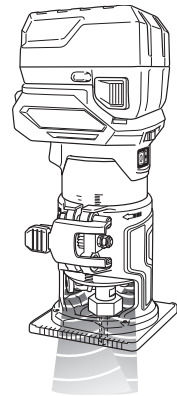
**Fig. 31**

# English

- (2) The bit rotates clockwise (arrow direction indicated on the base ass'y). To obtain maximum cutting effectiveness, feed the trimmer in conformance with the feed directions shown in **Fig. 32**.



4. LED light warning signals (**Fig. 33**)  
 This product features functions that are designed to protect the tool itself as well as the battery. While the switch is pulled, if any of the safeguard functions activate during operation, the LED light will blink as described in **Table 4**. When any of the safeguard functions are triggered, immediately remove your finger from the switch and follow the instructions described under corrective action.



**Fig. 33**

**Table 4**

Safeguard Function	LED Light Display	Corrective Action
Overload Protection	On 0.1 second/off 0.1 second ■ ■ ■ ■ ■ ■ ■ ■ ■ ■ ■ ■ ■ ■ ■ ■	Remove the cause of the overloading.
Temperature Protection	On 0.5 second/off 0.5 second ■■■ ■■■ ■■■	Allow the tool and battery to thoroughly cool.





**NOTE**

On occasion, about two seconds after stopping operation of the tool, the LED light will shut off and the power will switch OFF.  
 This means that either the power is near empty or that the battery is overheated.  
 In such a case, allow the battery to cool and then recharge it for use.

## 5. About Remaining Battery Indicator

When the power is ON, the remaining battery indicator lamp lights and the battery remaining power can be checked. (Fig. 34) The Table 5 shows the state of remaining battery indicator lamp and the battery remaining power.

Table 5

State of lamp	Battery Remaining Power
	The battery remaining power is enough.
	The battery remaining power is a half.
	The battery remaining power is nearly empty. Re-charge the battery soonest possible.
	No remaining battery charge

## NOTE

- If only one lamp of the remaining battery indicator lamp is blinking, the remaining battery charge is very low. The battery should be recharged as soon as possible.
- Do not give a strong shock to the display panel or break it. It may lead to a trouble.

As the remaining battery indicator shows somewhat differently depending on ambient temperature and battery characteristics, read it as a reference.

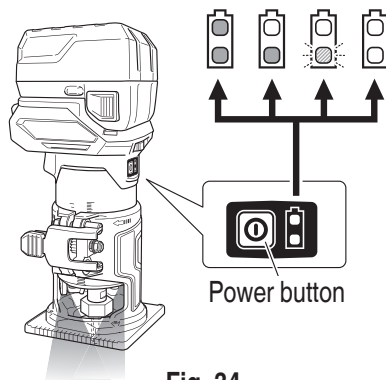


Fig. 34

## OPERATIONAL CAUTIONS

Resting the unit after continuous work

- (1) The power tool is equipped with a temperature protection circuit to protect the motor. Continuous work may cause the temperature of the unit to rise, activating the temperature protection circuit and automatically stopping operation. If this happens, allow the power tool to cool before resuming use.
- (2) After use for continuous work, rest the unit for 15 minutes or so when replacing the battery. The temperature of the motor, switch, etc., will rise if the work is started again immediately after battery replacement, eventually resulting in burnout.

## MAINTENANCE AND INSPECTION

### WARNING

Be sure to turn off the switch and pull out the battery before doing any inspection or maintenance.

#### 1. Inspecting the bit

Continued use of a dull or damaged bit will result in reduced cutting efficiency and may cause overloading of the motor. Replace the bit with a new one as soon as excessive abrasion is noted.

### CAUTION

If a dull bit is used, reactive force is increased during cutting operation. Avoid the use of the dull bit without repair.

#### 2. Inspecting the screws

Regularly inspect all screws and ensure that they are fully tightened. Should any of the screws be loosened, retighten them immediately.

### WARNING

Using this trimmer with loosened screws is extremely dangerous.

#### 3. Maintenance of the motor

The motor unit winding is the very “heart” of the power tool. Exercise due care to ensure the winding does not become damaged and/or wet with oil or water.

#### 4. Check for Dust

### WARNING

To prevent dust inhalation or eye irritation, wear protective safety goggles and a dust mask when using an air gun to clean.

Use an air gun or other similar tool to remove materials, chips, etc. which have adhered to the body (especially where indicated in Fig. 35), and wipe with a soft dry cloth or a cloth moistened with soapy water.

Do not use bleach, chlorine, gasoline or thinner, for they may damage the plastics. (Fig. 35)

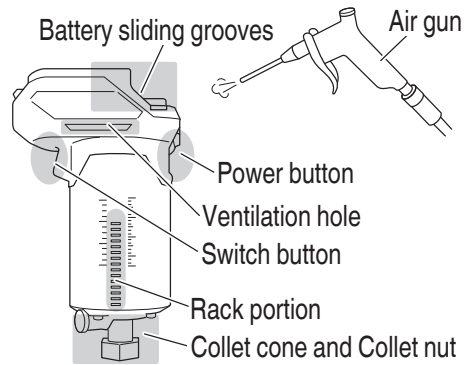


Fig. 35

#### 5. Inspection of terminals (tool and battery)

Check to make sure that swarf and dust have not collected on the terminals. On occasion check prior, during and after operation.

### CAUTION

Remove any swarf or dust which may have collected on the terminals. Failure to do so may result in malfunction.



## 6. Disposal of the exhausted battery

### WARNING

**Do not dispose of the exhausted battery. The battery must explode if it is incinerated. The battery is recyclable. At the end of its useful life, under various state and local laws, it may be illegal to dispose of this battery into the municipal waste stream. Check with your local solid waste officials for details in your area for recycling options or proper disposal.**

## 7. Storage

Storing in a place below 40°C and out of the reach of children.

### NOTE

Storing lithium-ion batteries

Make sure the lithium-ion batteries have been fully charged before storing them.

Prolonged storage (3 months or more) of batteries with a low charge may result in performance deterioration, significantly reducing battery usage time or rendering the batteries incapable of holding a charge.

However, significantly reduced battery usage time may be recovered by repeatedly charging and using the batteries two to five times.

If the battery usage time is extremely short despite repeated charging and use, consider the batteries dead and purchase new batteries.

## 8. Service and repairs

All quality power tools will eventually require servicing or replacement of parts because of wear from normal use. To assure that only authorized replacement parts will be used, all service and repairs must be performed by a HiKOKI AUTHORIZED SERVICE CENTER, ONLY.

### CAUTION

**In the operation and maintenance of power tools, the safety regulations and standards prescribed in each country must be observed.**

#### **Important notice on the batteries for the HiKOKI cordless power tools**

Please always use one of our designated genuine batteries. We cannot guarantee the safety and performance of our cordless power tool when used with batteries other than these designated by us, or when the battery is disassembled and modified (such as disassembly and replacement of cells or other internal parts).

## TROUBLESHOOTING GUIDE

### WARNING

- To avoid injury from an accidental start, turn the switch OFF and remove the plug from the power source or remove the battery from the main body before making any adjustments.
- All electrical or mechanical repairs should be done only by qualified service technicians. Contact HiKOKI Authorized Service Center.

#### 1. Power tool

Problem	Possible Cause	Remedy
Tool doesn't run	No remaining battery power	Charge the battery.
	Battery isn't fully installed.	Push the battery in until you hear a click.
	The power is OFF.	Press the power button to switch the power ON.
Tool suddenly stopped	Tool was overburdened	Get rid of the problem causing the overburden.
		During operation, lighten the applied pressure.
	Battery or tool overheated	Allow the tool and battery to thoroughly cool.
Doesn't cut well	No remaining battery power	Charge the battery.
	The bit is worn or missing teeth.	Replace with a new bit.
Doesn't cut well	The collet chuck is loose.	Firmly tighten the collet chuck.
	Remaining battery indicator lamp is blinking	Indicates that the remaining battery charge is very low.
Remaining battery indicator on the machine doesn't match the battery's remaining battery indicator	—	Refer to the indicator lamp on the battery.
Battery cannot be installed	Attempting to install a battery other than that specified for the tool.	Please install batteries that are multi volt or BSL18xx series.

## 2. Charger

Symptom	Possible cause	Remedy
The charge indicator lamp rapidly flickers purple, and battery charging doesn't begin.	The battery is not inserted all the way.	Insert the battery firmly.
	There is foreign matter in the battery terminal or where the battery is attached.	Remove the foreign matter.
The charge indicator lamp blinks red, and battery charging doesn't begin.	The battery is not inserted all the way.	Insert the battery firmly.
	The battery is overheated.	If left alone, the battery will automatically begin charging if its temperature decreases, but this may reduce battery life. It is recommended that the battery be cooled in a well-ventilated location away from direct sunlight before charging it.
Battery usage time is short even though the battery is fully charged.	The battery's life is depleted.	Replace the battery with a new one.
The battery takes a long time to charge.	The temperature of the battery, the charger, or the surrounding environment is extremely low.	Charge the battery indoors or in another warmer environment.
	The charger's vents are blocked, causing its internal components to overheat.	Avoid blocking the vents.
	The cooling fan is not running.	Contact a HiKOKI Authorized Service Center for repairs.
The USB power lamp has switched off and the USB device has stopped charging.	The battery's capacity has become low.	Replace the battery with one that has capacity remaining.
		Plug the charger's power plug into an electric socket.
USB power lamp does not switch off even though the USB device has finished charging.	The USB power lamp lights up green to indicate that USB charging is possible.	This is not a malfunction.
It is unclear what the charging status of a USB device is, or whether its charging is complete.	The USB power lamp does not switch off even when charging is complete.	Examine the USB device that is charging to confirm its charging status.

## English

Symptom	Possible cause	Remedy
Charging of a USB device pauses midway.	The charger was plugged into an electrical socket while the USB device was being charged using the battery as the power source.	This is not a malfunction. The charger pauses USB charging for about 5 seconds when it is differentiating between power sources.
	A battery was inserted into the charger while the USB device was being charged using a power socket as the power source.	
Charging of the USB device pauses midway when the battery and the USB device are being charged at the same time.	The battery has become fully charged.	This is not a malfunction. The charger pauses USB charging for about 5 seconds while it checks whether the battery has successfully completed charging.
Charging of the USB device doesn't start when the battery and the USB device are being charged at the same time.	The remaining battery capacity is extremely low.	This is not a malfunction. When the battery capacity reaches a certain level, USB charging automatically begins.

## SELECTING ACCESSORIES

Select accessories that are suited to a specific task.  
For details contact HiKOKI Authorized Service Center.



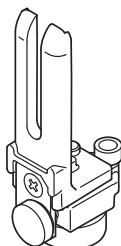
Part Number: 377117

Collet cone 6 mm

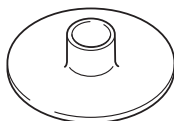


Part Number: 377133

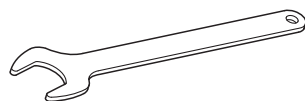
Collet cone 8 mm



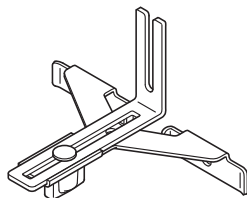
Part Number: 377127



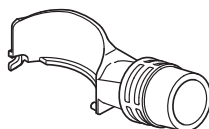
Part Number: 377129



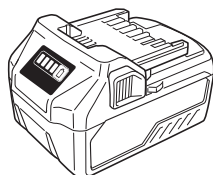
Part Number: 377128



Part Number: 377126

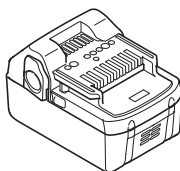


Part Number: 377131

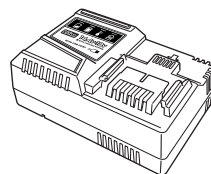


BSL36A18

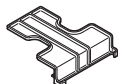
Battery



18 V (Li-ion)

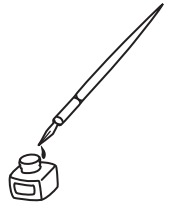


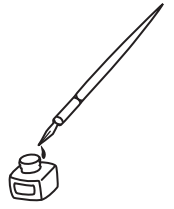
UC18YSL3  
(14.4 V–18 V)  
Charger



Part Number: 329897

Battery cover





服务中心  
高壹工机商业(上海)有限公司  
上海市闵行区浦江工业园区三鲁路3585号7幢3楼

制造商  
福建高壹工机有限公司  
福建省福州市福兴投资区湖塘路

**Koki Holdings Co., Ltd.**

111  
编号: C99740521 F  
发行日期: 2021年 11月  
中国印刷