

HiKOKI

充电式往复锯

Cordless Reciprocating Saw

CR 12DA

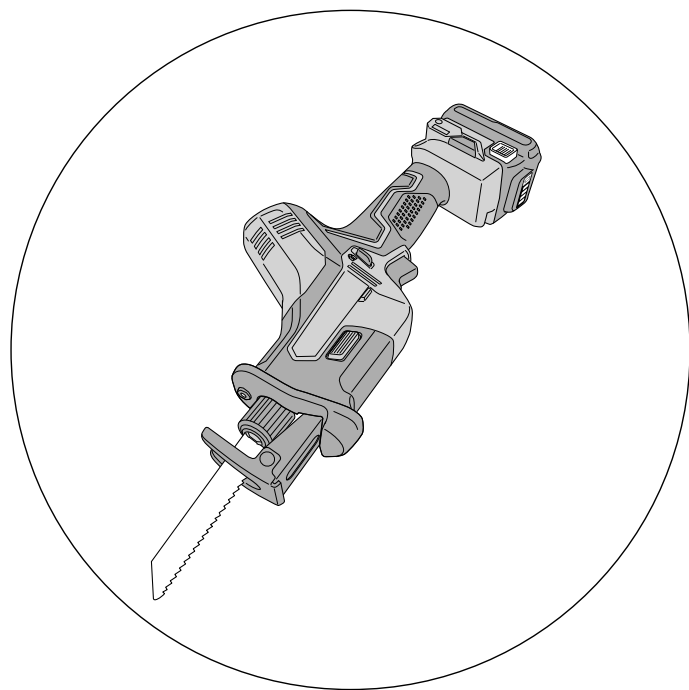

保留备用

Keep for future reference



使用说明书

Handling instructions

中文

English

目次

电动工具通用安全警告.....	2	用途.....	9
充电式往复锯使用注意事项.....	5	电池的拆卸 / 安装法.....	10
锂离子电池使用注意事项.....	5	充电.....	10
锂离子电池运输.....	7	作业之前.....	13
符号.....	7	使用方法.....	15
零件名称.....	8	操作上的注意事项.....	20
规格.....	9	维护和检查.....	20
标准附件.....	9	选择附件.....	22

电动工具通用安全警告

⚠ 警告！

阅读电动工具附带的所有安全警告、说明、插图和规格说明。
不遵照以下说明会导致电击、着火和 / 或严重伤害。

保存所有警告和说明书以备查阅。

在所有下列的警告中术语“电动工具”指市电驱动（有线）电动工具或电池驱动（无线）电动工具。

1) 工作场地的安全

- a) 保持工作场地清洁和明亮。
混乱和黑暗的场地会引发事故。
- b) 不要在易爆环境，如有易燃液体、气体或粉尘的环境下操作电动工具。
电动工具产生的火花会点燃粉尘或气体。
- c) 让儿童和旁观者离开后操作电动工具。
注意力不集中会使操作者失去对工具的控制。

2) 电气安全

- a) 电动工具插头必须与插座相配。绝不能以任何方式改装插头。需接地的电动工具不能使用任何转换插头。
未经改装的插头和相配的插座将减少电击危险。
- b) 避免人体接触接地表面，如管道、散热片和冰箱。
如果你身体接地会增加电击危险。
- c) 不得将电动工具暴露在雨中或潮湿环境中。
水进入电动工具将增加电击危险。
- d) 不得滥用电线。绝不能用电线搬运、拉动电动工具或拔出其插头。使电线远离热源、油、锐边或运动部件。
受损或缠绕的软线会增加电击危险。

- e) 当在户外使用电动工具时，使用适合户外使用的外接软线。
适合户外使用的软线将减少电击危险。
- f) 如果在潮湿环境下操作电动工具是不可避免的，应使用剩余电流动作保护器（RCD）。
使用RCD可减小电击危险。

3) 人身安全

- a) 保持警觉，当操作电动工具时关注所从事的操作并保持清醒。
当你感到疲倦，或在有药物、酒精或治疗反应时，不要操作电动工具。
在操作电动工具时瞬间的疏忽会导致严重人身伤害。
- b) 使用个人防护装置。始终佩戴护目镜。
安全装置，诸如适当条件下使用防尘面具、防滑安全鞋、安全帽、听力防护等装置能减少人身伤害。
- c) 防止意外起动。确保开关在连接电源和 / 或电池盒、拿起或搬运工具时处于关断位置。
手指放在已接通电源的开关上或开关处于接通时插入插头可能会导致危险。
- d) 在电动工具接通之前，拿掉所有调节钥匙或扳手。
遗留在电动工具旋转零件上的扳手或钥匙会导致人身伤害。
- e) 手不要伸展得太长。时刻注意立足点和身体平衡。
这样在意外情况下能很好地控制电动工具。
- f) 着装适当。不要穿宽松衣服或佩戴饰品。让衣服、手套和头发远离运动部件。
宽松衣服、佩饰或长发可能会卷入运动部件中。
- g) 如果提供了与排屑、集尘设备连接用的装置，要确保它们连接完好且使用得当。
使用这些装置可减少尘屑引起的危险。
- h) 请勿因频繁使用工具的熟悉感而掉以轻心，忽视工具的安全性原则。
粗心的行为可能会导致瞬间发生严重伤害。

4) 电动工具使用和注意事项

- a) 不要滥用电动工具，根据用途使用适当的电动工具。
选用适当设计的电动工具会使你工作更有效、更安全。
- b) 如果开关不能接通或关断工具电源，则不能使用该电动工具。
不能用开关来控制的电动工具是危险的且必须进行修理。
- c) 在进行任何调整、更换附件或存放电动工具之前，必须从电源上拔掉插头和 / 或取下电池盒（如果可拆卸）。
这种防护性措施将减少工具意外起动的危险。
- d) 将闲置不用的电动工具贮存在儿童所及范围之外，并且不要让不熟悉电动工具或对这些说明不了解的人操作电动工具。
电动工具在未经培训的用户手中是危险的。

中文

- e) 维护电动工具和附件。检查运动件是否调整到位或卡住，检查零件破损情况和影响电动工具运行的其他状况。
如有损坏，电动工具应在使用前修理好。
许多事故由维护不良的电动工具引发。
- f) 保持切削刀具锋利和清洁。
保养良好的有锋利切削刃的刀具不易卡住而且容易控制。
- g) 按照使用说明书，考虑作业条件和进行的作业来使用电动工具、附件和工具的刀头等。
将电动工具用于那些与其用途不符的操作可能会导致危险。
- h) 保持手柄和抓握表面干燥、清洁，远离油和油脂。
如果手柄和抓握表面湿滑，可能导致在发生意外情况时，无法安全操作和控制工具。

5) 电池式工具使用和注意事项

- a) 只用制造商规定的充电器充电。
将适用于某种电池盒的充电器用到其他电池盒时会发生着火危险。
- b) 只使用配有特制电池盒的电动工具。
使用其他电池盒会发生损坏和着火危险。
- c) 当电池盒不用时，将它远离其他金属物体，例如回形针、硬币、钥匙、钉子、螺钉或其他小金属物体，以防一端与另一端连接。
电池端部短路会引起燃烧或火灾。
- d) 在滥用条件下，液体会从电池中溅出；避免接触。如果无意间碰到了，用水冲洗。如果液体碰到了眼睛，还要寻求医疗帮助。
从电池中溅出的液体会发生腐蚀或燃烧。
- e) 请勿使用损坏或改装的电池盒或工具。
损坏或改装的电池可能会引发突发状况，导致火灾、爆炸或受伤。
- f) 请勿将电池盒或工具暴露在有火源或高温环境中。
如果暴露在有火源或130度以上高温的环境中，可能引起爆炸。
- g) 请完全按照充电说明进行操作，不要在说明中规定的温度范围外的环境中对电池盒或工具充电。
充电不当或在规定温度范围外的环境中充电可能会导致电池损坏，增加发生火灾的风险。

6) 维修

- a) 将你的电动工具送交专业维修人员，使用同样的备件进行修理。
这样将确保所维修的电动工具的安全性。
- b) 请勿维修已损坏的电池盒。
需由制造商或经授权的服务供应商进行维修。

注意！

不可让儿童和体弱人士靠近工作场所。

应将不使用的工具存放在儿童和体弱人士接触不到的地方。

充电式往复锯使用注意事项

1. 务请在 $0^{\circ}\text{C} \sim 40^{\circ}\text{C}$ 的温度下进行充电。温度低于 0°C 将会导致充电过度，极其危险。电池不能在高于 40°C 的温度下充电。
最适合于充电的温度是 $20 \sim 25^{\circ}\text{C}$ 。
2. 不要连续使用充电器。
一次充电完毕后，在15分钟内不要再次使用该充电器对电池充电。
3. 勿让杂质进入充电式电池连结口内。
4. 切勿拆卸充电式电池与充电器。
5. 切勿使充电式电池短路。使电池短路将会造成很大的电流和过热，从而烧坏电池。
6. 请勿将电池丢入火中。
电池受热将会爆炸。
7. 在墙上、地板上或天花板上切割时，请检查埋入的电线等。
8. 充电后电池寿命太短不够使用时，请尽快将电池送往经销店。请勿将用过的电池乱丢。
9. 请勿使用耗竭了的电池，否则会损坏充电器。
10. 请勿将异物插入充电器的通风口。
若将金属异物或易燃物插入通风口的话，将会引起触电事故或使充电器受损。
11. 长时间连续使用本电钻，可能会导致机体过热，对马达及开关造成损害，因此使用本机请勿连续超过15分钟。
12. 为保护您的听力请在工作时带上耳塞。
13. 切勿在工作中或刚刚结束工作时触摸锯条，因为在工作中锯条会变得很热，触摸其将会造成严重的烫伤。
14. 作业期间请确保全程握紧电机机身握把及外壳。否则产生的反作用力可能会导致不正确的或甚至危险的操作。
15. 在进行调整、更换附件或存放工具之前请取出电池或将开关置于锁定或关闭位置。

锂离子电池使用注意事项

为延长使用期限，锂离子电池备配停止输出的保护功能。

若是在使用本产品时发生下列1和3的情况，即使按下开关，马达也可能停止。这并非故障，而是启动保护功能的结果。

1. 在残留的电池电力即将耗尽时，马达会停止。
在这种情况下，请立即予以充电。
2. 若工具超过负荷，马达亦可能停止。在这种情况下，请松开工具的开关，试着消除超过负荷的原因。之后您就可以再度使用。
3. 若电池在过载工作情况下过热，电池电力可能会中止。
在这种情况下，请停止使用电池，让电池冷却。之后您就可以再度使用。

中文

此外，请留心下列的警告及注意事项。

警告！

为防止发生电池漏电、发热、冒烟、爆炸及提前点燃，请确保留意下列事项。

1. 确保电池上没有堆积削屑及灰尘。
 - 在工作时确定削屑及灰尘没有掉落在电池上。
 - 确定所有工作时掉落在电动工具上的削屑和灰尘没有堆积在电池上。
 - 请勿将未使用的电池存放在曝露于削屑和灰尘的位置。
 - 在存放电池之前，请清除任何可能附着在上面的削屑和灰尘，并请切勿将它与金属零件（螺丝、钉子等）存放在一起。
2. 请勿以钉子等利器刺穿电池、以铁锤敲打、踩踏、丢掷电池，或将其剧烈撞击。
3. 切勿使用明显损坏或变形的电池。
4. 使用电池时请勿颠倒电极。
5. 请勿直接连接电源插座或汽车点烟器孔座。
6. 请依规定方式使用电池，切勿移作他用。
7. 如果已过了再充电时间，电池仍无法完成充电，请立即停止继续再充电。
8. 请勿将电池放置于高温或高压处，例如微波炉、烘干机或高压容器内。
9. 在发觉有渗漏或异味时，请勿接近远离火源。
10. 请勿在会产生强烈静电的地方使用。
11. 如有电池渗漏、异味、发热、褪色或变形，或在使用、充电或存放时出现任何异常，请立即将它从装备或电池充电器拆下，并停止使用。
12. 请勿浸泡电池或让任何液体流入电池内部。导电液体进入（如水），可能造成电池损坏，甚至可导致火灾或爆炸。将电池存放在阴凉、干燥的地方，远离易燃物品。必须避免将电池置于腐蚀性气体环境中。

注意！

1. 若电池渗漏出的液体进入您的眼睛，请勿搓揉眼睛，并以自来水等干净清水充分冲洗，立刻送医。
若不加以处理，液体可能会导致眼睛不适。
2. 若液体渗漏至您的皮肤或衣物，请立即以自来水等清水冲洗。
上述情况可能会使皮肤受到刺激。
3. 若初次使用电池时发现生锈、异味、过热、褪色、变形及 / 或其它异常情况时，请勿使用并将该电池退还给供货商或厂商。

警告！

如果有导电异物进入锂电池，可能发生短路，并有可能发生火灾危险的可能。请在贮存电池时，遵守如下事项。

- 请不要在电池盒内放置导电物体，如钉子、钢丝、铜丝或其他电线。
- 或者将电池装在电动工具中，或者在牢固按入电池盖并挡住通风孔后再存放，以防止短路（参照图 1）。



图 1

锂离子电池运输**警告！**

告知运输公司，包装内包含一个锂离子电池，告知该公司其功率输出并且要按照运输公司的指引安排运输。

- 功率输出超过 100 Wh 的锂离子电池被视作危险物品运输分类并且需要特别申请程序。
- 对于境外运输，您必须遵守国际法以及输入国的规章和条例。

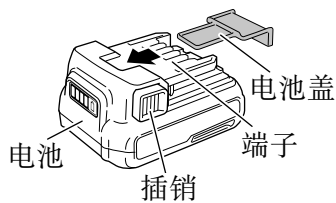

图 2

符号**警告！**

如下所示的符号用于本机。使用前请务必理解其含意。

	为降低伤害风险，用户必须阅读使用说明书	n_0	空载转速
	直流电	/min	每分钟的振动次数
V	额定电压		警告

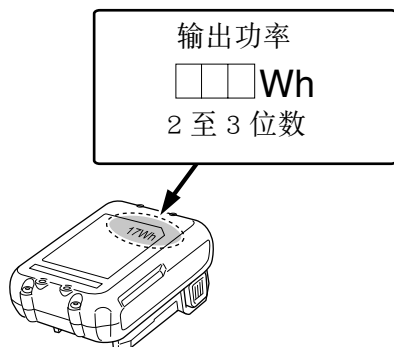
零件名称

1. 电动工具



图 3

2. 电池 (选购件)

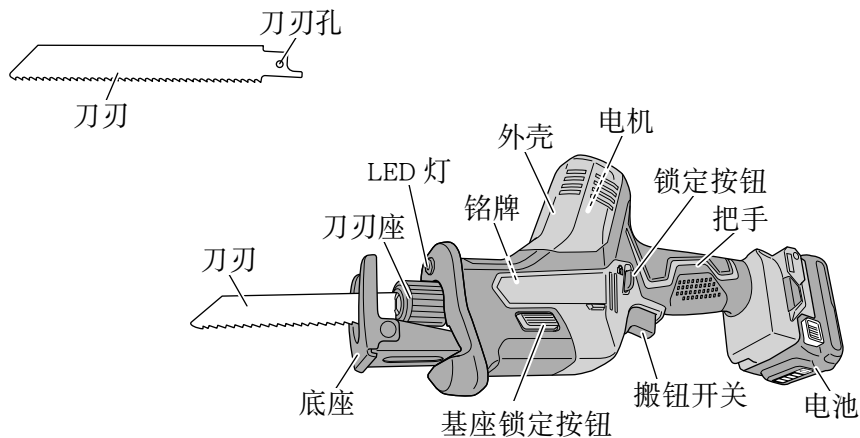
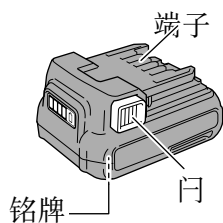

<BSL1225M>

图 4

3. 电池充电器 (选购件)

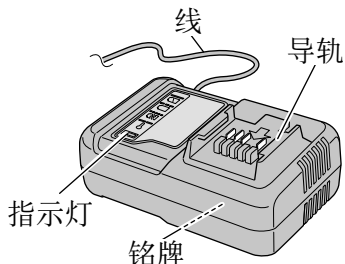

<UC12SL>

图 5

规格

电动工具



型式	CR12DA
无负荷速度	0 - 3200 /min
行程	13 mm
能力	软钢管：外径 50 mm
	聚氯乙烯管：外径 50 mm
	木材：厚度 50 mm
	软钢板：厚度 12 mm
电池	BSL1225M：锂离子 10.8 V - 12 V 最大 (2.5 Ah 3节)
重量	1.4 kg (安装 BSL1225M)

充电器 (分开销售)

型式	UC12SL
充电电压	10.8 V - 12 V 最大
重量	0.35 kg

标准附件

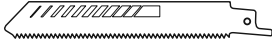
CR12DA 的附件请参见以下列表。

		CR12DA (NN)
刀刃 (107号)		1
刀刃 (5号)		1

用途

- 金属和不锈钢管的切锯。
- 各种木材的切锯。
- 软钢、铝和铜板的切锯。
- 苯酚树脂、聚氯乙烯等合成树脂的切锯。

电池的拆卸 / 安装法

1. 电池的拆卸法

请先紧抓住把手，然后再推压电池插销以拆下电池（参照图 6）。

注意！

切勿使电池短路。

2. 电池的安装法

插入电池时请注意极性（参照图 6）



图 6

充电

使用电动工具之前，按下述方法将电池进行充电。

1. 将充电器的电源线连接到插座。

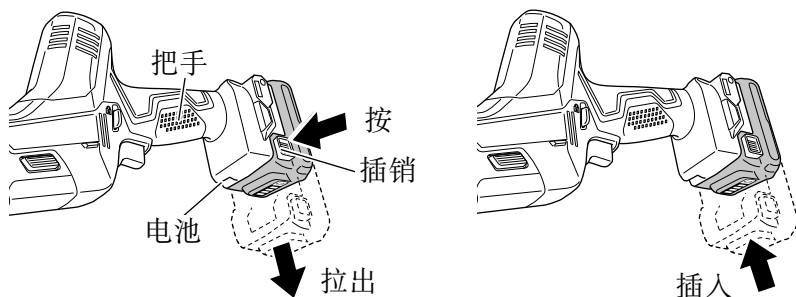
将充电器插头连接到插座时，指示灯闪烁红色（间隔为 1 秒）。

2. 将电池插入充电器。

如图 7 所示，将电池紧紧地插入充电器。

3. 充电

将电池插入充电器后，充电器上的指示灯将持续点亮呈红色。电池充满电后，信号灯会呈红色闪烁。（闪烁间隔为 1 秒钟）（参见表 1）

(1) 指示灯显示

如表 1 所示，根据充电器或电池的状态，信号灯会有不同的指示。



图 7

中文

4. 从电源插座拔下充电器的电源线。

5. 握紧充电器并取出电池。

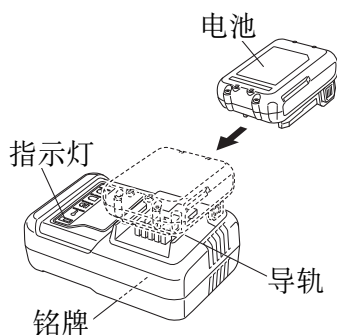
注：

充电后，先将电池从充电器中取出，然后妥善保管。

关于新电池的放电。

新电池内部的化学物质未被激活或电池长时间不使用时，初次或第二次使用时需要将其放电至较低电量。这只是暂时现象，将电池充电2-3次即可恢复为充电所需的正常时间。

较长时间保持电池性能的方法

(1) 在电池电力完全耗尽之前进行充电。

感到电动工具的能力变弱时，请停止使用并给电池充电。若您继续使用电动工具并耗尽电力，电池可能会损坏或其使用寿命缩短。

(2) 避免在高温环境中充电。

使用后可充电电池的温度将迅速升高。若使用后立即对这种电池进行充电，其内部化学物质会劣化，电池使用寿命将缩短。请稍等片刻，待电池冷却后再进行充电。

注意！

○ 如果电池长时间放置在阳光直接照射的地方或者刚刚使用完毕时，电池会变热。如果此时对电池充电，充电器上的指示灯会点亮1秒钟，不点亮0.5秒钟（熄灭0.5秒钟）。

在此情况下，先让电池冷却下来，然后再充电。

○ 信号灯呈红色快速闪烁(闪烁间隔为0.2秒钟)时，请检查充电器的电池连接器内是否有异物并加以清除。若没有异物，则可能是电池或充电器发生了故障，请将其送往当地授权服务中心。

○ 因内置的微机需要约3秒钟才能确认正用UC12SL进行充电的电池已被取出，因此请待3秒钟后再重新插入电池继续充电。如果在不到3秒内就插入电池，则电池可能充电不正常。

作业之前

注意！

为避免发生严重事故，请确保开关处于关闭位置，并取出电池。

1. 检查工作区域环境。
检查工作区域，确保没有杂物且不杂乱。
请勿使无关人员靠近。确保照明和通风充足。
2. 安装锯条
该工具采用了不使用扳钳或其他工具便可装卸锯条的可装卸式装置。
 - (1) 按照箭头所示方向扭转刀刃座，将刀刃完全插入刀刃座的小插槽中。（图 8）
 - (2) 松开刀刃座时，刀刃将被锁定到位。
根据操作情况，刀刃可以朝上/下安装。（图 9）
 - (3) 用手试着拉刀刃背两三次，以确认刀刃已安装牢固。（图 10）

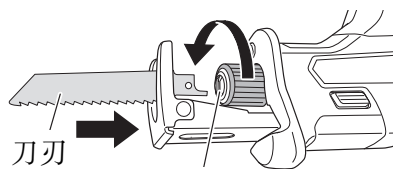

刀刃座的插槽

图 8



图 9



图 10

注意！

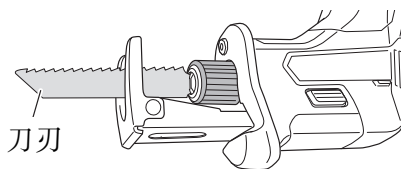
当拉动锯条时务必从后侧拉动，拉动锯条的其他部分将造成人身伤害。

注：

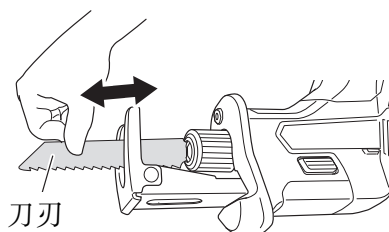
无需插入到基座即可安装刀刃。
但在这种情况下，请务必在安装刀刃后将基座安装到工具上。

3. 安装曲线锯片（另售）
T 型柄曲线锯片可与本产品一同使用。（图 11）

与往复曲线锯片的安装方式相同。确保刀刃的柄部插入中心腔中。（图 12）

用手试着拉刀刃背两三次，以确认刀刃已安装牢固。



图 11



图 12

中文

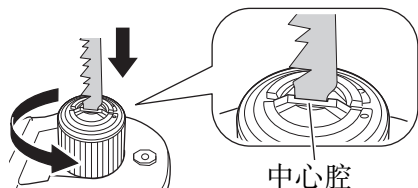
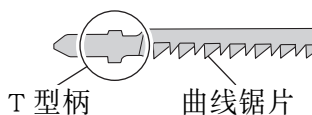
4. 卸下锯条

注意！

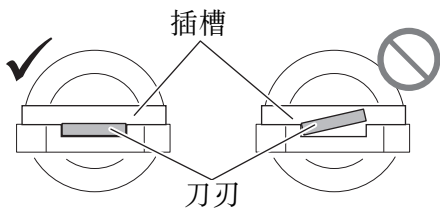
切勿用手触摸刚刚使用过的锯条，否则，灼热的金属极易烫伤您的皮肤。

- (1) 转动刀刃座后，将刀刃朝下。刀刃会自行脱落。如果刀刃未掉下来，用手将刀刃拔出。（图 13）

注：

如果曲线锯片不会掉下，请轻按侧面的刀刃以拆下刀刃孔并移除刀刃。



图 13

当刀刃损坏时

即使当刀刃破损并残留在刀刃座的小插槽内时，若扭转刀刃座并使刀刃朝下，它仍会自行掉下。若未自行掉下，请按下述步骤将它取出。

- (1) 若损坏的刀刃某部分粘在了刀刃座的小插槽中，拔出插条并将刀刃拔出。
- (2) 若损坏的锯条藏在小插槽内部，请用锯条的尖部将其钩住并取出。（图 14）

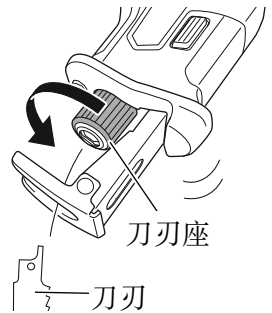

图 14

电锯的维护和检查

- (1) 使用后，请用气刷或刷子清除掉锯条上的灰尘、泥土、尘沙或潮气等，以确保锯条的工作顺畅。

注意！

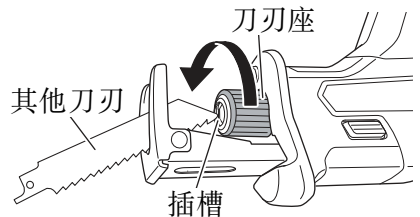
请勿使用带有磨损刀刃孔的刀刃。否则，刀刃可能会掉下，导致人员受伤。（图 15）



图 15

4. 调结基座

为最大限度地延长刀刃的使用寿命，请滑入或滑出基座，调整行程长度以便于高效使用。

按下基座锁定按钮可前后调节基座。

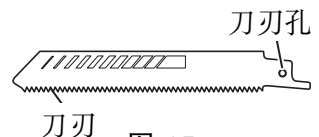
听到“咔哒”声时，基座即固定到位。(图 16)



图 16

警告！

为了避免人员受伤和机器损坏，请勿在未安装基座的情况下操作本往复锯。否则可能会因刀刃座撞击工件而造成往复运动机构损坏。

5. 检查电池的插入

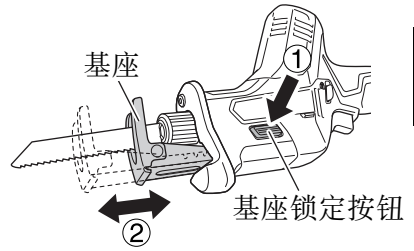
警告！

若电源开关接通，则插入电池后，电动工具将出其不意地立刻转动，从而导致严重事故。

注意！

请确保电池装入正确的位置，直至发出喀嗒声，否则可能会使电池突然掉落，导致使用者或周围人员受伤。

使用方法**警告！**

请勿触碰移动的部件。

注意！

- 在作业中请小心勿使锯屑、灰尘、水等通过柱塞部份进入机内。若锯屑等积于柱塞部份，请务必在使用前加以清除。
- 确保从外壳顶部握住机身(图 17)。
- 在使用时，在切锯作业中请将底座压在材料上面。若未将底座紧紧压在工件上，振动会导致刀刃损坏。因此，有时刀刃端会接触管内壁，导致刀刃损坏。



图 17

中文

- 请选择长度最适当的刀刃。理论上，减去行程量后从刀刃座突出的刀刃长度应大于材料。(参照图 18)

若切锯超过刀刃切锯能力的大工件、大木块等，刀刃可能会接触到管内壁和木料等，从而发生危险。(参照图 19)。

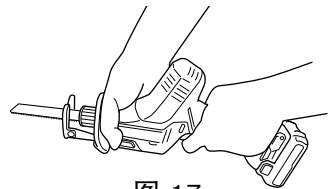
- 为延长使用期限，锂离子电池配备停止输出的保护功能。因此，若工具超过负荷，马达亦可能停止。然而，这并非故障问题，而是保护功能作用的结果。在这种情况下，请松开工具的开关，试着消除超过负荷的原因。
- 移动刀刃进行切锯时，请勿将工具从工件上移开。
- 完成作业后，取出电池。

注：

请勿锁住马达。若马达锁住，请立即断开开关。若马达已被锁住一段时间，可能会使马达或电池烧损。



图 18



图 19

1. 开关的操作

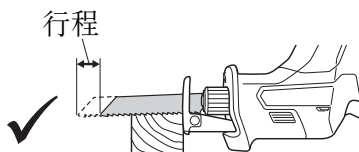
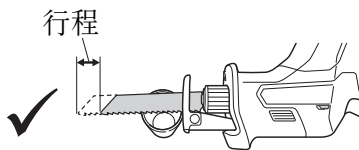
(1) 锁定解除按钮

本工具配有锁定解除按钮。如要启动工具，按下锁定解除按钮，然后按下扳机开关。(图 20)

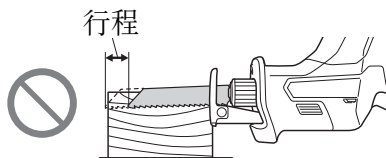
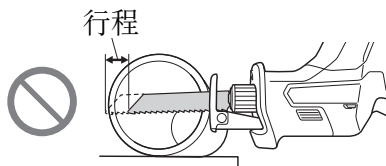
注意！

请勿固定锁定解除按钮。

此外，携带工具时，使手指远离扳机开关。否则可能会在不经意间按下扳机开关，导致意外事故。



图 20

(2) 搬钮开关

本工具配有控制各种速度的搬钮开关。通过按压和松开搬钮可将工具打开或关闭，通过按压搬钮来调整至合适的电锯的速度（从铭牌标注的最小速度至最大速度），向下按时速度加大，松开时速度减小。（图 21）

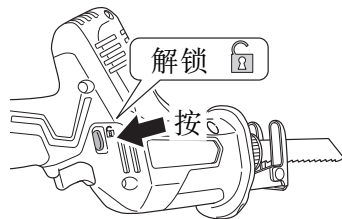
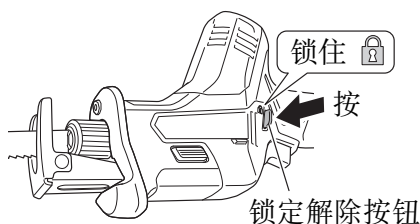

图 21

2. LED 灯使用方法

拔出开关后，LED 灯将自动点亮工具尖头部分（图 22）。

开关松开后，LED 灯将会自动关闭 10 秒钟。

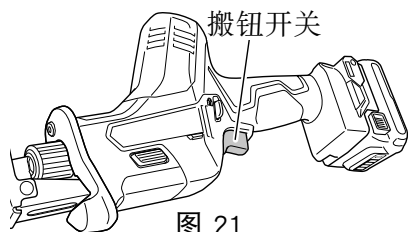
LED 灯也具有警示信号功能，在使用期间点亮。

详情见“7. LED 灯警示信号”。



图 22

注意！

- 请不要直视灯光，避免眼睛直接受灯光照射。如果眼睛持续受灯光照射，会伤害眼睛。
- 用软布仔细擦拭附着在 LED 灯镜片上的灰尘或污垢，小心不要划伤镜片。如果划伤 LED 灯的镜片，可能会导致亮度减弱。

3. 切锯金属材料

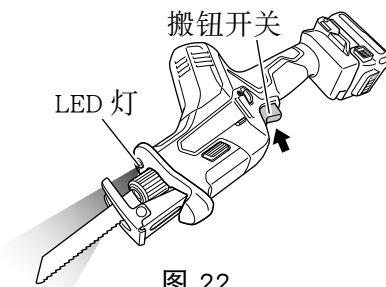
注意！

- 将底座紧紧按在工件之上。
- 切锯时请勿给刀刃施加异常力量。否则很容易损坏刀刃。
- 根据切割物的构成或锯条的不同有时马达会锁住。一旦马达锁住，请立即关闭开关。
- 不要在易爆环境，如有易燃液体、气体或粉尘的环境下操作电动工具。往复锯产生的火花会点燃粉尘或气体。

(1) 在作业前牢牢固定工件。（图 23）

(2) 在切锯金属材料时，请使用适当的机油（涡轮油等）。未使用液体机油时，请给工件涂上润滑油。



图 23

注意！

若未使用机油，刀刃的使用寿命会大幅缩短。

中文

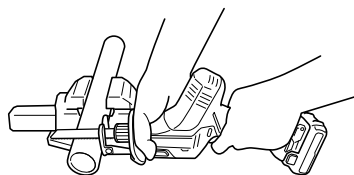
4. 切锯木料

切锯木料时，在开始操作前务必先牢牢固定工件。(图 24)



图 24

注意！

- 切锯时请勿给刀刃施加异常力量。同时，请将底座紧紧压在木料上。
- 将材料切割成小圆弧时须降低进料速度，速度过快可能会损坏刀刃。

5. 插入切锯

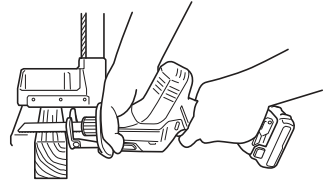
使用本电动往复锯，可在木合板和薄板材料上进行插入切锯。

请尽量使用短而薄的刀刃。在切锯作业中请务必小心操作并遵守以下步骤。

- (1) 将基座压在材料上并拉动扳机开关时，使刀刃前端远离材料。(图 25)。
- (2) 慢慢切锯材料时，轻微拉动扳机开关以保持低速。(图 26)。
- (3) 完全拉动开关后，缓慢移动锯。(图 27)。



图 25



图 26

注：

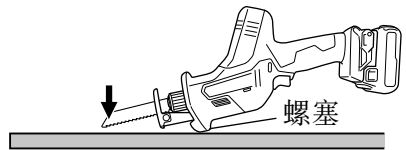
- 使用螺塞或基座作为支架，从刀刃前端逐渐锯入。
- 基座是金属制品，将其用作支架时，可能会根据切锯材料的不同而划伤或损坏表面。在这种情况下，请使用螺塞作为支架。如果在切锯窗户时移除基座，请在继续操作工具时确保将基座重新安装到工具上。

注意！

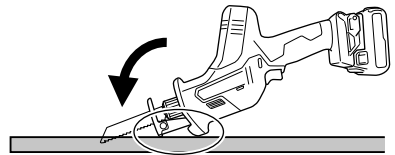
- 避免对金属材料进行切锯，否则很容易损坏刀刃。
- 在刀刃前端压在切锯材料上时切勿扣扳机。否则，当刀刃接触材料时很容易被损坏。
- 务必紧紧抓住机身缓慢地进行切锯。在切锯作业中若对刀刃异常用力，则很容易损坏刀刃。



图 27

6. 剩余电池电量指示灯（仅 BSL1240M，BSL1225M）

可以按下剩余电池电量指示灯开关点亮指示灯，查看电池的剩余电量。（图 28，表 4）

按住剩余电池电量指示灯开关约3秒后，指示灯将熄灭。

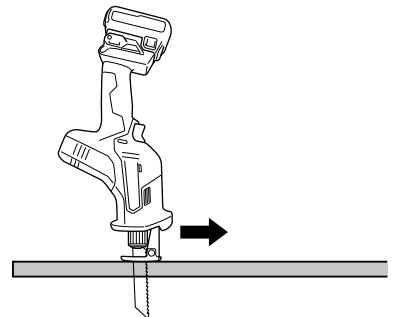
环境温度和电池状态可能会对剩余电池电量产生轻微的影响，因此，建议您仅将指示灯作为参考。

此外，电动工具或充电器上的剩余电池电量指示灯可能有所不同。



图 28

表 4

指示灯状态	电池剩余电量
	点亮； 电池剩余电量超过 75%
	点亮； 电池剩余电量为 50% - 75%
	点亮； 电池剩余电量为 25% - 50%
	点亮； 电池剩余电量不到 25%
	闪烁； 电池剩余电量即将耗尽。请尽快对电池进行充电。
	闪烁； 因高温暂停输出从电动工具中取下电池，让电池完全冷却。
	闪烁； 因失败或故障暂停输出。电池可能出现故障，请与经销商联系。

环境温度和电池特性不同，则所显示的电池剩余电量也会有些许不同，以上内容仅供参考。

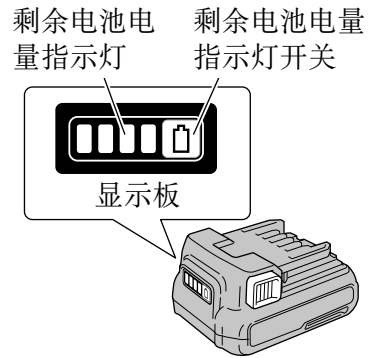
注：

请勿强烈撞击或破坏开关面板。否则可能会导致故障。

中文

7. LED 灯警示信号 (图 29)

该产品设计出具有保护该工具以及电池的功能。当拔出开关, 如果在操作过程中任何保护功能启动, LED 灯将会如表 5 所描述的进行闪光。当启动任何保护功能, 立即将您的手指从开关上移开并按照正确步骤所描述的指引进行操作。



图 29

表 5

保护功能	LED 灯显示	正确步骤
负重过度保护	开启0.25秒/关闭0.25秒	解除负担过重原因。
温度保护		让该工具和电池得到充分冷却。
低压保护	■ ■ ■ ■ ■	对电池充电。

操作上的注意事项

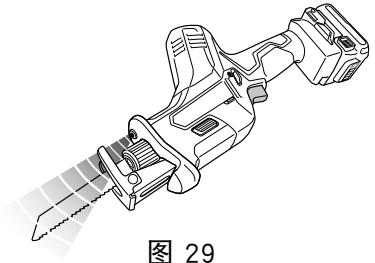
连续作业后须让电动工具休息片刻

(1) 电动工具带有温度保护电路以保护马达。

长时间连续作业可能会导致机器温度升高、触发温度保护电路并自动停止作业。

如果发生这种情况, 请让电动工具冷却后再使用。

(2) 请在长时间连续作业后或更换电池后, 使机器静止15分钟。如果在更换电池后立刻开始作业, 马达和开关等的温度将会升高, 结果导致烧毁。

维护和检查

注意!

维护和检查前请务必关闭开关。

1. 检查刀刃

如继续使用已钝了的或已损坏了的刀刃, 会降低工作效率并可能会引起马达超负荷。因此, 一旦注意到刀刃磨损, 请立即用新刀刃更换之。

注意!

若使用较钝的刀刃作业, 则切锯时产生的反作用力会增加。请避免使用未经维修的较钝刀刃。

2. 检查安装螺钉

要经常检查安装螺钉是否紧固妥善。若发现螺钉松了，应立即重新扭紧，否则会导致严重的事故。

3. 电动机的维护

电动机绕线是电动工具的“心脏部”应仔细检查有无损伤，是否被油液或水沾湿。

4. 清理外部

电动工具沾污时，用干软布或沾肥皂水的布擦拭。切勿使用氯溶液、汽油或稀释剂，以免塑胶部分溶化。

5. 润滑

考虑到该工具在正常作业条件下的预期使用寿命，轴承已经过优质润滑油的充分润滑。因此，无需进一步润滑。

6. 收藏

电动工具应收藏于温度低于 40°C 和小孩拿不到的地方。

注：

存放锂离子电池

在存放前请确保电池已完全充电。

电池在低电量的状态下长时间存放（3个月或更长），可能会导致电池性能劣化，使用时间明显减少或无法进行充电。

但是，即使是使用时间明显减少的电池，通过反复充电和使用2~5次，有时也可恢复使用时间。

若反复充电和使用后电池的使用时间仍非常短，请认作为电池已达到了使用寿命并更换新的电池。

注意！

在操作和维修电动工具时，必须遵守贵国制定的安全的有关规则和标准。

关于 HiKOKI 牌无线电动工具的重要通知：

请确保始终使用我们指定的正版电池。如果使用我们指定以外的电池，或对电池进行拆卸和改动（例如拆卸和更换电池组件或其他内部部件），那么我们无法保证我们无线电动工具的安全性和使用性能。

选择附件

有关详细信息请联系 HIKOKI 授权服务中心。

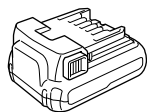

BSL1215

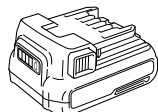

BSL1225M

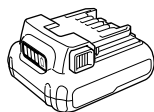

BSL1240M

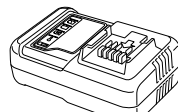

UC12SL

10.8 V - 12 V 最大
(锂离子) 电池

(10.8 V - 12 V 最大)
充电器



产品编号: 374778
电池盖

刀刃:

107号 BI-METAL 刀刃 产品编号: 318617

5号 HCS 刀刃 (HCS: 高速炭钢) 产品编号: 958185

CONTENTS

GENERAL POWER TOOL SAFETY WARNINGS	23
PRECAUTIONS FOR CORDLESS RECIPROCATING SAW	26
CAUTION ON LITHIUM-ION BATTERY	27
REGARDING LITHIUM-ION BATTERY TRANSPORTATION	29
SYMBOL.....	29
NAME OF PARTS.....	30
SPECIFICATIONS.....	31
STANDARD ACCESSORIES	31
APPLICATIONS.....	31
BATTERY REMOVAL/INSTALLATION	32
CHARGING	32
PRIOR TO OPERATION.....	35
HOW TO USE.....	38
OPERATIONAL CAUTIONS.....	43
MAINTENANCE AND INSPECTION	43
SELECTING ACCESSORIES.....	44

GENERAL POWER TOOL SAFETY WARNINGS

WARNING

Read all safety warnings, instructions, illustrations and specifications provided with this power tool.

Failure to follow all instructions listed below may result in electric shock, fire and/or serious injury.

Save all warnings and instructions for future reference.

The term “power tool” in the warnings refers to your mains-operated (corded) power tool or battery-operated (cordless) power tool.

1) Work area safety

a) **Keep work area clean and well lit.**

Cluttered or dark areas invite accidents.

b) **Do not operate power tools in explosive atmospheres, such as in the presence of flammable liquids, gases or dust.**

Power tools create sparks which may ignite the dust or fumes.

c) **Keep children and bystanders away while operating a power tool.**

Distractions can cause you to lose control.

2) Electrical safety

a) **Power tool plugs must match the outlet.**

Never modify the plug in any way.

Do not use any adapter plugs with earthed (grounded) power tools.

Unmodified plugs and matching outlets will reduce risk of electric shock.

English

- b) **Avoid body contact with earthed or grounded surfaces, such as pipes, radiators, ranges and refrigerators.**
There is an increased risk of electric shock if your body is earthed or grounded.
- c) **Do not expose power tools to rain or wet conditions.**
Water entering a power tool will increase the risk of electric shock.
- d) **Do not abuse the cord. Never use the cord for carrying, pulling or unplugging the power tool.**
*Keep cord away from heat, oil, sharp edges or moving parts.
Damaged or entangled cords increase the risk of electric shock.*
- e) **When operating a power tool outdoors, use an extension cord suitable for outdoor use.**
Use of a cord suitable for outdoor use reduces the risk of electric shock.
- f) **If operating a power tool in a damp location is unavoidable, use a residual current device (RCD) protected supply.**
Use of an RCD reduces the risk of electric shock.

3) **Personal safety**

- a) **Stay alert, watch what you are doing and use common sense when operating a power tool.**
Do not use a power tool while you are tired or under the influence of drugs, alcohol or medication.
A moment of inattention while operating power tools may result in serious personal injury.
- b) **Use personal protective equipment. Always wear eye protection.**
Protective equipment such as a dust mask, non-skid safety shoes, hard hat or hearing protection used for appropriate conditions will reduce personal injuries.
- c) **Prevent unintentional starting. Ensure the switch is in the off-position before connecting to power source and/or battery pack, picking up or carrying the tool.**
Carrying power tools with your finger on the switch or energising power tools that have the switch on invites accidents.
- d) **Remove any adjusting key or wrench before turning the power tool on.**
A wrench or a key left attached to a rotating part of the power tool may result in personal injury.
- e) **Do not overreach. Keep proper footing and balance at all times.**
This enables better control of the power tool in unexpected situations.
- f) **Dress properly. Do not wear loose clothing or jewellery. Keep your hair, clothing and gloves away from moving parts.**
Loose clothes, jewellery or long hair can be caught in moving parts.
- g) **If devices are provided for the connection of dust extraction and collection facilities, ensure these are connected and properly used.**
Use of dust collection can reduce dust-related hazards.
- h) **Do not let familiarity gained from frequent use of tools allow you to become complacent and ignore tool safety principles.**
A careless action can cause severe injury within a fraction of a second.

4) **Power tool use and care**

- a) **Do not force the power tool. Use the correct power tool for your application.**
The correct power tool will do the job better and safer at the rate for which it was designed.
- b) **Do not use the power tool if the switch does not turn it on and off.**
Any power tool that cannot be controlled with the switch is dangerous and must be repaired.
- c) **Disconnect the plug from the power source and/or remove the battery pack, if detachable, from the power tool before making any adjustments, changing accessories, or storing power tools.**
Such preventive safety measures reduce the risk of starting the power tool accidentally.
- d) **Store idle power tools out of the reach of children and do not allow persons unfamiliar with the power tool or these instructions to operate the power tool.**
Power tools are dangerous in the hands of untrained users.
- e) **Maintain power tools and accessories. Check for misalignment or binding of moving parts, breakage of parts and any other condition that may affect the power tool's operation.**
If damaged, have the power tool repaired before use.
Many accidents are caused by poorly maintained power tools.
- f) **Keep cutting tools sharp and clean.**
Properly maintained cutting tools with sharp cutting edges are less likely to bind and are easier to control.
- g) **Use the power tool, accessories and tool bits etc. in accordance with these instructions, taking into account the working conditions and the work to be performed.**
Use of the power tool for operations different from those intended could result in a hazardous situation.
- h) **Keep handles and grasping surfaces dry, clean and free from oil and grease.**
Slippery handles and grasping surfaces do not allow for safe handling and control of the tool in unexpected situations.

5) **Battery tool use and care**

- a) **Recharge only with the charger specified by the manufacturer.**
A charger that is suitable for one type of battery pack may create a risk of fire when used with another battery pack.
- b) **Use power tools only with specifically designated battery packs.**
Use of any other battery packs may create a risk of injury and fire.
- c) **When battery pack is not in use, keep it away from other metal objects, like paper clips, coins, keys, nails, screws or other small metal objects, that can make a connection from one terminal to another.**
Shorting the battery terminals together may cause burns or a fire.
- d) **Under abusive conditions, liquid may be ejected from the battery; avoid contact. If contact accidentally occurs, flush with water. If liquid contacts eyes, additionally seek medical help.**
Liquid ejected from the battery may cause irritation or burns.

English

- e) **Do not use a battery pack or tool that is damaged or modified.**
Damaged or modified batteries may exhibit unpredictable behaviour resulting in fire, explosion or risk of injury.
 - f) **Do not expose a battery pack or tool to fire or excessive temperature.**
Exposure to fire or temperature above 130 °C may cause explosion.
 - g) **Follow all charging instructions and do not charge the battery pack or tool outside the temperature range specified in the instructions.**
Charging improperly or at temperatures outside the specified range may damage the battery and increase the risk of fire.
- 6) **Service**
- a) **Have your power tool serviced by a qualified repair person using only identical replacement parts.**
This will ensure that the safety of the power tool is maintained.
 - b) **Never service damaged battery packs.**
Service of battery packs should only be performed by the manufacturer or authorized service providers.

CAUTION

Keep children and infirm persons away.

When not in use, tools should be stored out of reach of children and infirm persons.

PRECAUTIONS FOR CORDLESS RECIPROCATING SAW

1. **Always charge the battery at a temperature of 0 – 40°C.**
A temperature of less than 0°C will result in over charging which is dangerous. The battery cannot be charged at a temperature higher than 40°C.
The most suitable temperature for charging is that of 20 – 25°C.
2. **Do not use the charger continuously.**
When one charging is completed, leave the charger for about 15 minutes before the next charging of battery.
3. **Do not allow foreign matter to enter the hole for connecting the rechargeable battery.**
4. **Never disassemble the rechargeable battery and charger.**
5. **Never short-circuit the rechargeable battery.** Short-circuiting the battery will cause a great electric current and overheat. It results in burn or damage to the battery.
6. **Do not dispose of the battery in fire.**
If the battery is burnt, it may explode.
7. **When cutting in wall, floor or ceiling, check for buried electric power cord, etc.**
8. **Bring the battery to the shop from which it was purchased as soon as the post-charging battery life becomes too short for practical use. Do not dispose of the exhausted battery.**
9. **Using an exhausted battery will damage the charger.**
10. **Do not insert object into the air ventilation slots of the charger.**
Inserting metal objects or inflammables into the charger air ventilation slots will result in electrical shock hazard or damaged charger.

11. When using this unit continuously, the unit may overheat, leading to damage in the motor and switch. Please leave it without using it for approximately 15 minutes.
12. Wear earplugs to protect your ears during operation.
13. Do not touch the blade during or immediately after operation. The blade becomes very hot during operation and could cause serious burns.
14. Always hold the body handle and housing of the power tool firmly. Otherwise the counterforce produced may result in inaccurate and even dangerous operation.
15. Remove the battery from tool or place the switch in the locked or off position before making any adjustments, changing accessories, or storing the tools.

CAUTION ON LITHIUM-ION BATTERY

To extend the lifetime, the lithium-ion battery equips with the protection function to stop the output.

In the cases of 1 to 3 described below, when using this product, even if you are pulling the switch, the motor may stop. This is not the trouble but the result of protection function.

1. When the battery power remaining runs out, the motor stops.
In such case, charge it up immediately.
2. If the tool is overloaded, the motor may stop. In this case, release the switch of tool and eliminate causes of overloading. After that, you can use it again.
3. If the battery is overheated under overload work, the battery power may stop.
In this case, stop using the battery and let the battery cool. After that, you can use it again.

Furthermore, please heed the following warning and caution.

WARNING

In order to prevent any battery leakage, heat generation, smoke emission, explosion and ignition beforehand, please be sure to heed the following precautions.

1. Make sure that swarf and dust do not collect on the battery.
 - During work make sure that swarf and dust do not fall on the battery.
 - Make sure that any swarf and dust falling on the power tool during work do not collect on the battery.
 - Do not store an unused battery in a location exposed to swarf and dust.
 - Before storing a battery, remove any swarf and dust that may adhere to it and do not store it together with metal parts (screws, nails, etc.).
2. Do not pierce battery with a sharp object such as a nail, strike with a hammer, step on, throw or subject the battery to severe physical shock.
3. Do not use an apparently damaged or deformed battery.
4. Do not use the battery in reverse polarity.
5. Do not connect directly to an electrical outlets or car cigarette lighter sockets.
6. Do not use the battery for a purpose other than those specified.
7. If the battery charging fails to complete even when a specified recharging time has elapsed, immediately stop further recharging.

English

8. Do not put or subject the battery to high temperatures or high pressure such as into a microwave oven, dryer, or high pressure container.
9. Keep away from fire immediately when leakage or foul odor are detected.
10. Do not use in a location where strong static electricity generates.
11. If there is battery leakage, foul odor, heat generated, discolored or deformed, or in any way appears abnormal during use, recharging or storage, immediately remove it from the equipment or battery charger, and stop use.
12. Do not immerse the battery or allow any fluids to flow inside. Conductive liquid ingress, such as water, can cause damage resulting in fire or explosion. Store your battery in a cool, dry place, away from combustible and flammable items. Corrosive gas atmospheres must be avoided.

CAUTION

1. If liquid leaking from the battery gets into your eyes, do not rub your eyes and wash them well with fresh clean water such as tap water and contact a doctor immediately.
If left untreated, the liquid may cause eye-problems.
2. If liquid leaks onto your skin or clothes, wash well with clean water such as tap water immediately.
There is a possibility that this can cause skin irritation.
3. If you find rust, foul odor, overheating, discolor, deformation, and/or other irregularities when using the battery for the first time, do not use and return it to your supplier or vendor.

WARNING

If an electrically conductive foreign object enters the terminals of the lithium ion battery, a short-circuit may occur resulting in the risk of fire. Please observe the following matters when storing the battery.

- Do not place electrically conductive cuttings, nails, steel wire, copper wire or other wire in the storage case.
- Either install the battery in the power tool or store by securely pressing into the battery cover until the ventilation holes are concealed to prevent short-circuits (See Fig. 1).

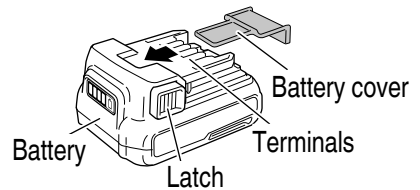

Fig. 1

REGARDING LITHIUM-ION BATTERY TRANSPORTATION

WARNING

Notify the transporting company that a package contains a lithium-ion battery, inform the company of its power output and follow the instructions of the transportation company when arranging transport.

- Lithium-ion batteries that exceed a power output of 100 Wh are considered to be in the freight classification of Dangerous Goods and will require special application procedures.
- For transportation abroad, you must comply with international law and the rules and regulations of the destination country.

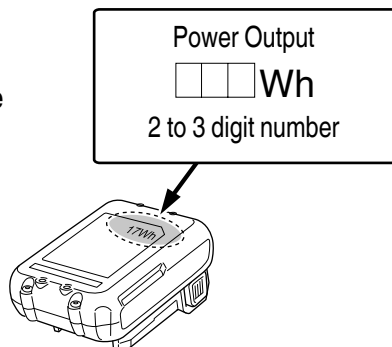





Fig. 2

SYMBOL

WARNING

The following show symbols used for the machine. Be sure that you understand their meaning before use.

	To reduce the risk of injury, user must read instruction manual.	n_0	No-load speed
	Direct current	/min	Oscillation per minute
V	Rated voltage		Warning

NAME OF PARTS

1. POWER TOOL

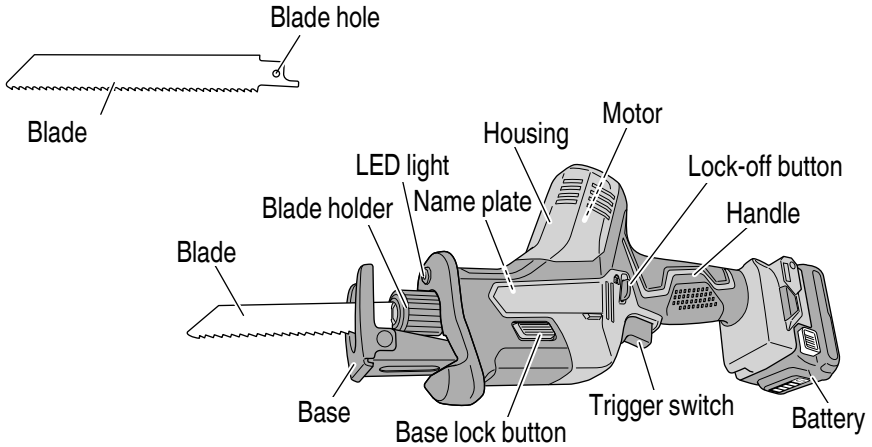
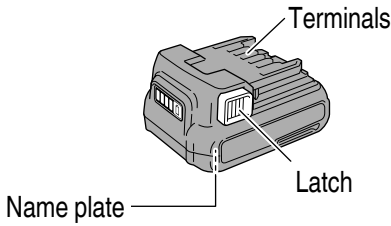

Fig. 3

2. Battery (Optional accessories)



<BSL1225M>

Fig. 4

3. Battery Charger (Optional accessories)

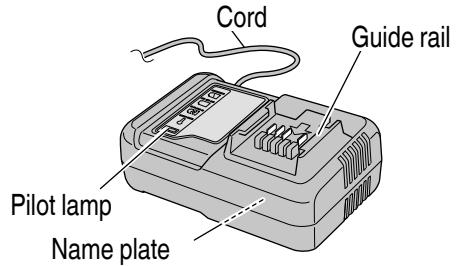

<UC12SL>

Fig. 5

SPECIFICATIONS

Power Tool



Model	CR12DA
No-load speed	0 – 3200 /min
Stroke	13 mm
Capacity	Mild Steel Pipe: O.D. 50 mm
	Vinyl Chloride Pipe: O.D. 50 mm
	Wood: Depth 50 mm
	Mild Steel Plate: Thickness 12 mm
Battery	BSL1225M: Li-ion 10.8 V – 12 V Peak (2.5 Ah 3 cells)
Weight	1.4 kg (BSL1225M attached)

Charger (sold separately)

Model	UC12SL
Charging voltage	10.8 V – 12 V Peak
Weight	0.35 kg

STANDARD ACCESSORIES

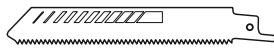
See the list below to check the accessories for CR12DA.

		CR12DA (NN)
Blade (No. 107)		1
Blade (No. 5)		1

APPLICATIONS

- Cutting metal and stainless steel pipe.
- Cutting various lumbers.
- Cutting mild steel, aluminum and copper plate.
- Cutting synthetic resins, such as phenol resin and vinyl chloride.

BATTERY REMOVAL/INSTALLATION

1. Battery removal
Hold the handle tightly and push the battery latches to remove the battery (see **Fig. 6**).

CAUTION

Never short-circuit the battery.

2. Battery installation
Insert the battery while observing its polarities (See **Fig. 6**).

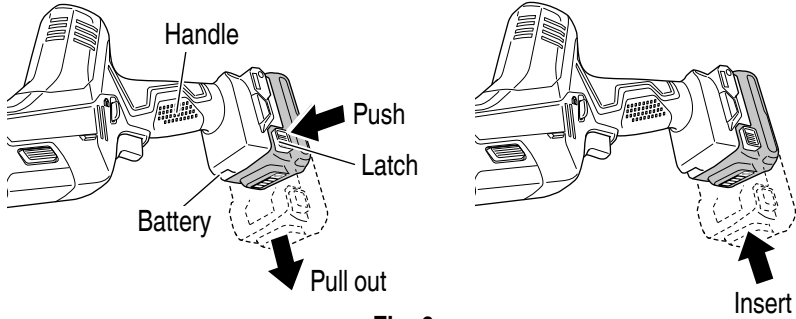

Fig. 6

CHARGING

Before using the power tool, charge the battery as follows.

1. **Connect the charger's power cord to the receptacle.**
When connecting the plug of the charger to a receptacle, the pilot lamp will blink in red (At 1-second intervals).
 2. **Insert the battery into the charger.**
Firmly insert the battery into the charger as shown in **Fig. 7**.
 3. **Charging**
When inserting a battery in the charger, the pilot lamp will light up continuously in red.
When the battery becomes fully recharged, the pilot lamp will blink in red. (At 1-second intervals.) (See **Table 1**)
- (1) Pilot lamp indication
The indications of the pilot lamp will be as shown in **Table 1**, according to the condition of the charger or the battery.

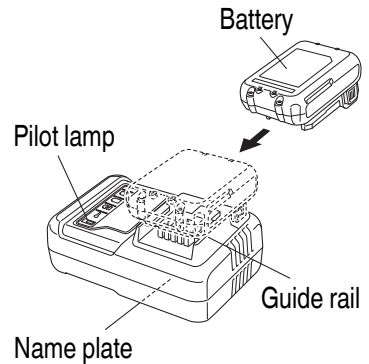

Fig. 7

English

4. **Disconnect the charger's power cord from the receptacle.**
5. **Hold the charger firmly and pull out the battery.**

NOTE

Be sure to pull out the battery from the charger after use, and then keep it.

Regarding electric discharge in case of new batteries, etc.

As the internal chemical substance of new batteries and batteries that have not been used for an extended period is not activated, the electric discharge might be low when using them the first and second time. This is a temporary phenomenon, and normal time required for recharging will be restored by recharging the batteries 2 – 3 times.

How to make the batteries perform longer.

- (1) **Recharge the batteries before they become completely exhausted.**
When you feel that the power of the tool becomes weaker, stop using the tool and recharge its battery. If you continue to use the tool and exhaust the electric current, the battery may be damaged and its life will become shorter.
- (2) **Avoid recharging at high temperatures.**
A rechargeable battery will be hot immediately after use. If such a battery is recharged immediately after use, its internal chemical substance will deteriorate, and the battery life will be shortened. Leave the battery and recharge it after it has cooled for a while.

CAUTION

- **If the battery is charged while it is heated because it has been left for a long time in a location subject to direct sunlight or because the battery has just been used, the pilot lamp of the charger lights for 1 second, does not light for 0.5 seconds (off for 0.5 seconds). In such a case, first let the battery cool, then start charging.**
- **When the pilot lamp flickers in red (at 0.2-seconds intervals), check for and take out any foreign objects in the charger's battery connector. If there are no foreign objects, it is probable that the battery or charger is malfunctioning. Take it to your authorized Service Center.**
- **Since the built-in micro computer takes about 3 seconds to confirm that the battery being charged with UC12SL is taken out, wait for a minimum of 3 seconds before reinserting it to continue charging. If the battery is reinserted within 3 seconds, the battery may not be properly charged.**

PRIOR TO OPERATION

CAUTION

To avoid serious accident, ensure the switch is in the OFF position, and pull out the battery.

1. Check the work area environment
Check the work area to make sure that it is clear of debris and clutter.
Clear the area of unnecessary personnel. Ensure that lighting and ventilation is adequate.
2. Mounting the blade
This unit employs a detachable mechanism that enables mounting and removal of saw blades without the use of a wrench or other tools.
 - (1) Turning the blade holder in the direction indicated by the arrow, insert the blade all the way into the small slit of the blade holder. (Fig. 8)
 - (2) The blade will be locked in place when the blade holder is released.
The blade can be attached facing up or down depending on the operation. (Fig. 9)
 - (3) Pull the back of the saw blade two or three times by hand and check that the blade is securely mounted. (Fig. 10)

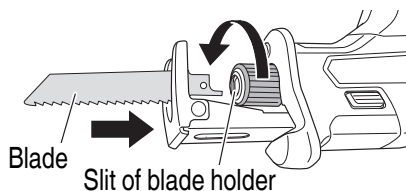

Fig. 8

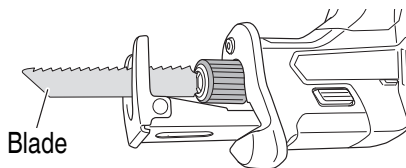

Fig. 9

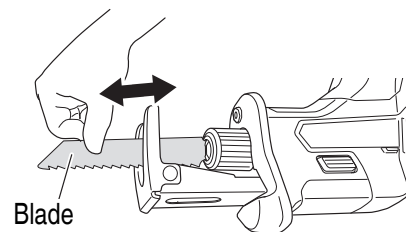

Fig. 10

CAUTION

When pulling the saw blade, be absolutely sure to pull it from the back. Pulling other parts of the blade will result in an injury.

NOTE

The blade can be mounted without fitting it into the base.
However, in this case, always make sure that the base is attached to the tool after mounting the blade.

English

3. Mounting the jigsaw blade (sold separately)
A T-shank jigsaw blade can be used with this product. (Fig. 11)

Mounted in the same manner as a reciprocating saw blade. Make sure that the shank of the blade is fitted into the center cavity. (Fig. 12)
Pull the back of the saw blade two or three times by hand and check that the blade is securely mounted.

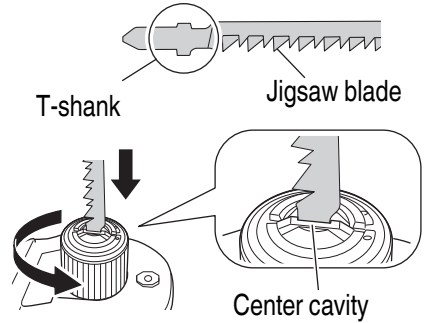

Fig. 11

CAUTION

Never touch the saw blade immediately after use. The metal is hot and can easily burn your skin.

- (1) After turning the blade holder, point the blade downward. The blade should fall out on its own. If the blade fails to fall out, pull it out by hand. (Fig. 13)

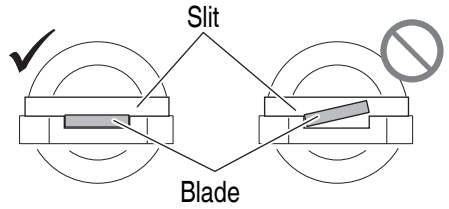

Fig. 12

NOTE

If the jigsaw blade will not fall out, lightly press the blade on the side to detach the blade hole and remove the blade.

WHEN THE BLADE IS BROKEN

Even when the saw blade is broken and remains inside the small slit of the blade holder, it should fall out when the blade holder is turned and the blade is pointed downward. If the blade fails to fall out on its own, take it out by using the procedures described below.

- (1) If a part of the broken saw blade is sticking out of the small slit of the blade holder, pull out the protruding part and take the blade out.
- (2) If the broken saw blade is hidden inside the small slit, hook the broken blade using a tip of another saw blade and take it out. (Fig. 14)

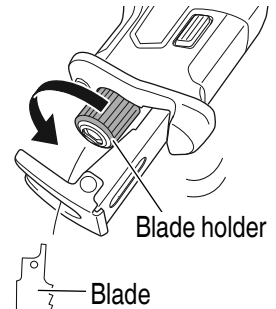

Fig. 13

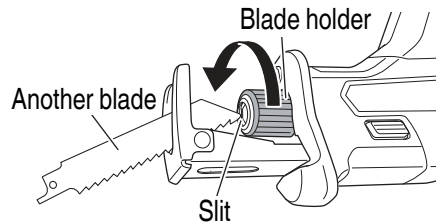

Fig. 14

MAINTENANCE AND INSPECTION OF SAW BLADE MOUNT

- (1) After use, blow away sawdust, earth, sand, moisture, etc., with air or brush them away with a brush, etc., to ensure that the blade mount can function smoothly.

CAUTION

Do not use any saw blade with a worn-out blade hole. Otherwise, the saw blade can come off, resulting in personal injury. (Fig. 15)

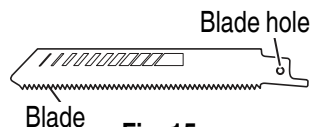

Fig. 15

4. Adjusting the base
To maximize blade life, the base slides in or out to allow the stroke length to be adjusted for better efficiency. Pressing the base lock button will allow the base to be adjusted forward or back. The base is fixed in position when you hear a "click". (Fig. 16)

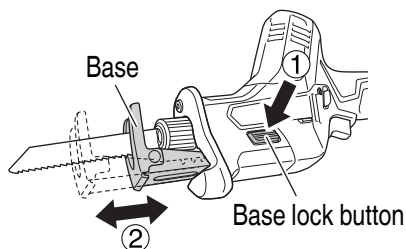

Fig. 16

WARNING

To avoid injury and damage, do not operate the saw without the base in place. The blade holder may strike against the workpiece and damage the reciprocating mechanism.

5. Check battery insertion

WARNING

If the battery is inserted while the power switch is in the ON position, the power tool will start operating immediately, inviting serious accident.

CAUTION

Until the battery locks in place with a little click, if not, it may accidentally fall out of the tool causing injury to you or someone around you.

HOW TO USE

WARNING

Never touch the moving parts.

CAUTION

- Be careful not to let sawdust, earth, moisture, etc., enter the inside of the machine through the plunger section during operation. If sawdust and the like accumulate in the plunger section, always clean it before use.
- Be sure to hold the body from the top of the housing (Fig. 17).
- During use, press the base against the material while cutting. Vibration can damage the saw blade if the base is not pressed firmly against the workpiece. Furthermore, a tip of the saw blade can sometimes contact the inner wall of the pipe, damaging the saw blade.
- Select a saw blade of the most appropriate length. Ideally, the length protruding from the base of the saw blade after subtracting the stroke quantity should be larger than the material (see Fig. 18). If you cut a large pipe, large block of wood, etc., that exceeds the cutting capacity of a blade; there is a risk that the blade may contact with the inner wall of the pipe, wood, etc., resulting in damage (Fig. 19).
- To extend the lifetime, the lithium-ion battery equips with the protection function to stop the output. Therefore, if the tool is overloaded, the motor may stop. However, this is not the trouble but the result of protection function. In this case, release the switch of tool and eliminate the causes of overloading.
- Don't remove the tool from workpiece during a cut while the saw blade is moving.
- Pull out the battery after completing operation.

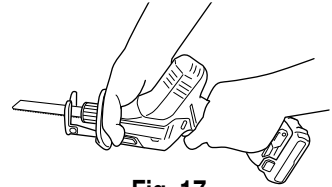

Fig. 17

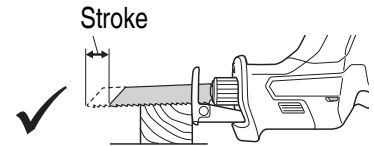
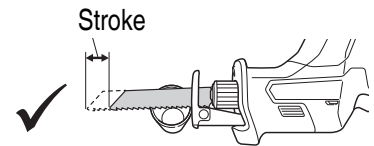

Fig. 18

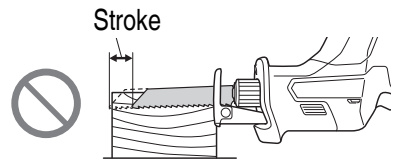
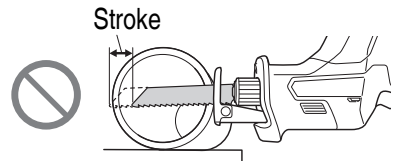

Fig. 19

NOTE

Take care not to lock the motor. If the motor is locked, immediately turn the power off. If the motor is locked for a while, the motor or battery may be burnt.

1. Switch operation

(1) Lock-off button

The tool is equipped with a lock-off button. To start the tool, press the lock-off button and then squeeze the trigger switch. (Fig. 20)

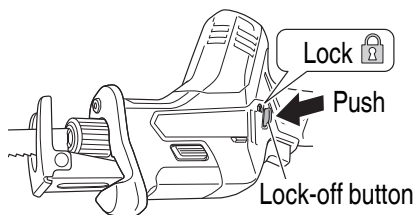
**CAUTION**

Do not fix and secure the lock-off button. Besides, keep your finger off the trigger switch when the tool is being carried around. Otherwise, the trigger switch can be inadvertently turned ON, resulting in unexpected accidents.

(2) Trigger switch

This tool is equipped with a variable speed controlled trigger switch. The tool can be turned "ON" or "OFF" by squeezing or releasing the trigger. The blade plunger stroke rate can be adjusted from the minimum nameplate stroke rate by the pressure you apply to the trigger. Apply more pressure to increase the speed and release pressure to decrease speed. (Fig. 21)

2. How to use the LED light

While the switch is pulled, the LED light will automatically light up the tip portion of the tool. (Fig. 22)

The LED light will automatically turn off the switch is released.

The LED light also functions as a warning signal that lights up during use.

For details, see "7. LED light warning signals".

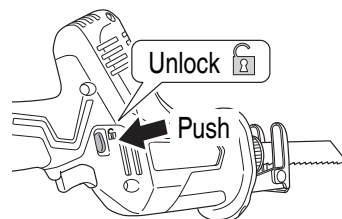

Fig. 20

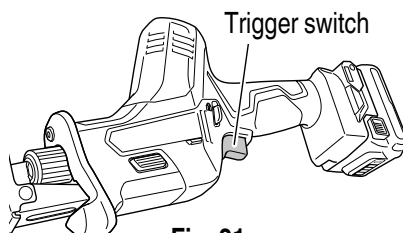

Fig. 21

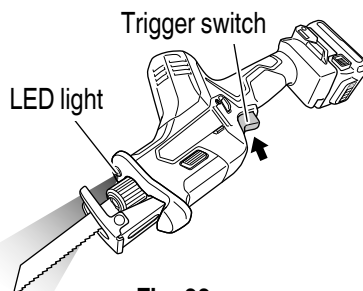

Fig. 22

CAUTION

- Do not expose directly your eye to the light by looking into the light. If your eye is continuously exposed to the light, your eye will be hurt.
- Wipe off any dirt or grime attached to the lens of the LED light with a soft cloth, being careful not to scratch the lens. Scratches on the lens of the LED light can result in decreased brightness.

English

3. Cutting metallic materials

CAUTION

- Press the base firmly against the workpiece.
- Never apply any unreasonable force to the saw blade when cutting. Doing so can easily break the blade.
- The motor can be locked sometimes, depending on the combination of the material to be cut and the blade. Whenever the motor gets locked, switch it off immediately.
- Do not operate power tools in explosive atmospheres, such as in the presence of flammable liquids, gases or dust. Reciprocating saw create sparks which may ignite the dust or fumes.

- (1) Fasten a workpiece firmly before operation. (Fig. 23)
- (2) When cutting metallic materials, use proper machine oil (turbine oil, etc.). When not using liquid machine oil, apply grease over the workpiece.

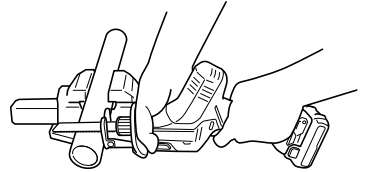

Fig. 23

CAUTION

The service life of the saw blade will be drastically shortened if you don't use machine oil.

4. Cutting lumber
When cutting lumber, make sure that the workpiece is fastened firmly before beginning. (Fig. 24)

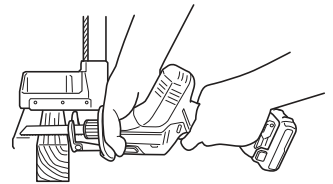

Fig. 24

CAUTION

- Never apply any unreasonable force to the saw blade when cutting. Also remember to press the base against the lumber firmly.
- Delay the feed speed when cutting the material into small circular arcs. An unreasonably fast feed may break the blade.

5. Plunge cutting
With this tool, you can perform plunge cutting on plywood panels and thin board materials. Use the saw blade that is as short and thick as possible. Be sure to use caution during the cutting operation and observe the following procedures.

- (1) Press the base against the material, keeping the tip of the blade away from the material when you pull the trigger switch. (Fig. 25).
- (2) Pull lightly on the trigger switch to maintain a low speed as you gradually saw into the material. (Fig. 26).

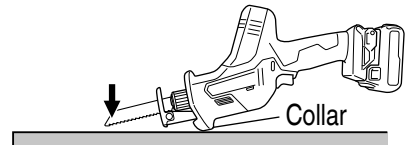

Fig. 25

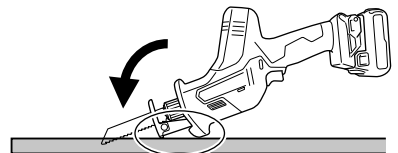

Fig. 26

- (3) Pull the switch all the way and slowly advance the saw. (Fig. 27).

NOTE

- Using the collar or the base as support, gradually cut in from the tip of the blade.
- As the base is metal, using it for support may scratch or damage the surface depending on the material being cut. In this case, use the collar as support. If you remove the base when window cutting, make sure it is re-attached to the tool when you continue operating the tool.

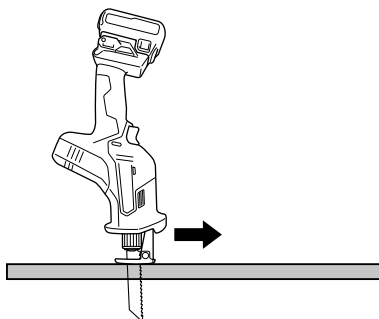

Fig. 27

CAUTION

- **Avoid plunge cutting for metallic materials. This can easily damage the blade.**
- **Never pull the Trigger switch while the tip of the saw blade is pressed against the material. If you do so, the blade can easily be damaged when it collides with the material.**
- **Make absolutely sure that you cut slowly while holding the body firmly. If you apply any unreasonable force to the saw blade during the cutting operation, the blade can easily be damaged.**

6. Remaining battery indicator (BSL1240M, BSL1225M only)

You can check the battery's remaining capacity by pressing the remaining battery indicator switch to light the indicator lamp. (Fig. 28, Table 4)

The indicator will shut off approximately 3 seconds after the remaining battery indicator switch is pressed.

It is best to use the remaining battery indicator as a guide since there are slight differences such as ambient temperature and the condition of the battery.

Also, the remaining battery indicator may vary from those equipped to a tool or charger.

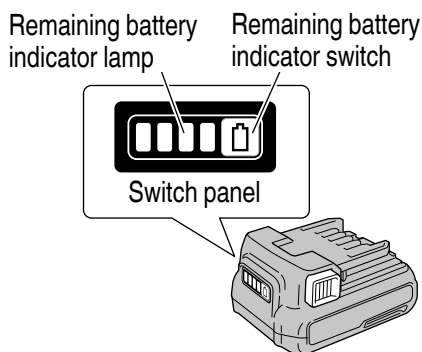

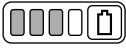
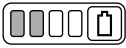
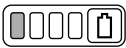

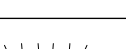



Fig. 28

Table 4

State of lamp	Battery Remaining Power
	Lights ; The battery remaining power is over 75%
	Lights ; The battery remaining power is 50% – 75%.
	Lights ; The battery remaining power is 25% – 50%.
	Lights ; The battery remaining power is less than 25%
	Blinks ; The battery remaining power is nearly empty. Recharge the battery soonest possible.
	Blinks ; Output suspended due to high temperature. Remove the battery from the tool and allow it to fully cool down.
	Blinks ; Output suspended due to failure or malfunction. The problem may be the battery so please contact your dealer.

As the remaining battery indicator shows somewhat differently depending on ambient temperature and battery characteristics, read it as a reference.

NOTE

Do not give a strong shock to the switch panel or break it. It may lead to a trouble.

7. LED light warning signals (**Fig. 29**)

This product features functions that are designed to protect the tool itself as well as the battery. While the switch is pulled, if any of the safeguard functions activate during operation, the LED light will blink as described in **Table 5**.

When any of the safeguard functions are triggered, immediately remove your finger from the switch and follow the instructions described under corrective action.

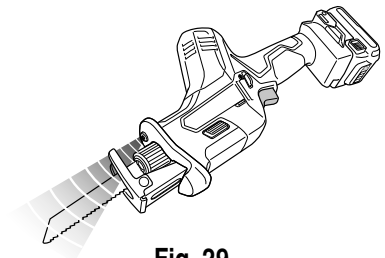



Fig. 29

Table 5

Safeguard Function	LED Light Display	Corrective Action
Overload Protection	On 0.25 second/off 0.25 second 	Remove the cause of the overload.
Temperature Protection		Allow the tool and battery to thoroughly cool.
Low Voltage Protection		Recharge the battery.

OPERATIONAL CAUTIONS

Resting the unit after continuous work

- (1) The power tool is equipped with a temperature protection circuit to protect the motor. Continuous work may cause the temperature of the unit to rise, activating the temperature protection circuit and automatically stopping operation. If this happens, allow the power tool to cool before resuming use.
- (2) After use for continuous works, rest the unit for 15 minutes or so when replacing the battery. The temperature of the motor, switch, etc., will rise if the work is started again immediately after battery replacement, eventually resulting in burnout.

MAINTENANCE AND INSPECTION

CAUTION

Be sure to turned off the switch and remove the battery before maintenance and inspection.

1. Inspecting the blade
Continued use of a dull or damaged blade will result in reduced cutting efficiency and may cause overloading of the motor. Replace the blade with a new one as soon as excessive abrasion is noted.

CAUTION

If a dull saw blade is used, reactive force is increased during cutting operation. Avoid the use of the dull saw blade without repair.

2. Inspecting the mounting screws
Regularly inspect all mounting screws and ensure that they are properly tightened. Should any of the screws be loose, retighten them immediately. Failure to do so could result in serious hazard.
3. Maintenance of the motor
The motor unit winding is the very "heart" of the power tool. Exercise due care to ensure the winding does not become damaged and/or wet with oil or water.
4. Cleaning of the outside
When the Cordless Reciprocating Saw is stained, wipe with a soft dry cloth or a cloth moistened with soapy water. Do not use chloric solvents, gasoline or paint thinner, as they melt plastics.
5. Lubrication
The bearings in this tool have been sufficiently lubricated with quality lubricating oil, taking into account the expected life of this tool under normal operating conditions. As a result, no further lubrication is necessary.
6. Storage
Store the Cordless Reciprocating Saw in a place in which the temperature is less than 40°C, and out of reach of children.

English

NOTE

Storing Lithium-ion Batteries

Make sure the batteries have been fully charged before storing them.

Prolonged storage (3 months or more) of batteries with a low charge may result in performance deterioration, significantly reducing battery usage time or rendering the batteries incapable of holding a charge.

However, significantly reduced battery usage time may be recovered by repeatedly charging and using the batteries two to five times.

If the battery usage time is extremely short despite repeated charging and use, consider the batteries dead and purchase new batteries.

CAUTION

In the operation and maintenance of power tools, the safety regulations and standards prescribed in each country must be observed.

Important notice on the batteries for the HiKOKI cordless power tools

Please always use one of our designated genuine batteries. We cannot guarantee the safety and performance of our cordless power tool when used with batteries other than these designated by us, or when the battery is disassembled and modified (such as disassembly and replacement of cells or other internal parts).

SELECTING ACCESSORIES

For details contact HiKOKI Authorized Service Center.

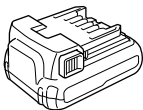

BSL1215

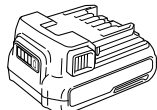

BSL1225M

10.8 V – 12 V Peak
(Li-ion) Battery

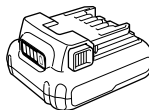

BSL1240M

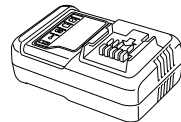

UC12SL

(10.8 V – 12 V Peak)
Charger



Part Number: 374778
Battery cover

Blades:

No. 107 BI-METAL Blades. Parts Number: 318617

No. 5 HCS Blades (HCS: Highspeed Carbon Steel) Parts Number: 958185

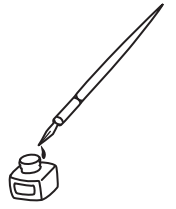

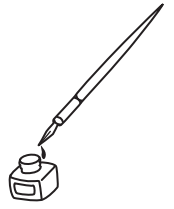

产品中有害物质的名称及含量

部件名称	有害物质					
	铅 (Pb)	汞 (Hg)	镉 (Cd)	六价铬 (Cr(VI))	多溴联苯 (PBB)	多溴二苯醚 (PBDE)
外壳部件	×	○	○	○	○	○
电机部件	×	○	○	○	○	○
开关	○	○	×	○	○	○
电镀部件（钢叶片等）	×	○	○	×	○	○
传动部件（齿轮轴等）	×	○	○	○	○	○
电源部件 (电线、引线等)	×	○	○	○	○	○
各种螺丝	○	○	○	○	○	○
铜焊部件 (超硬锯片等)	○	○	×	○	○	○
其它机械部件 (金属件等)	×	○	○	○	○	○
润滑剂（润滑脂等）	×	○	○	○	○	○
充电器	×	○	○	○	○	○
电池	×	○	×	○	○	○

本表格依据 SJ/T 11364 的规定编制。

○：表示该有害物质在该部件所有均质材料中的含量均在 GB/T26572 规定的限量要求以下。

×：表示该有害物质至少在该部件的某一均质材料中的含量超出 GB/T26572 规定的限量要求。

服务中心
高壹工机商业（上海）有限公司
上海市闵行区浦江工业园区三鲁路 3585 号 7 幢 3 楼

制造商
广东高壹工机有限公司
广东省广州市番禺区化龙镇工业路富裕围工业村

Koki Holdings Co., Ltd.

005
编号：C99738021 G
发行日期：2020年 5月
中国印刷