

# HiKOKI

电动曲线锯  
Jig Saw

中文  
English

## CJ 90VST2

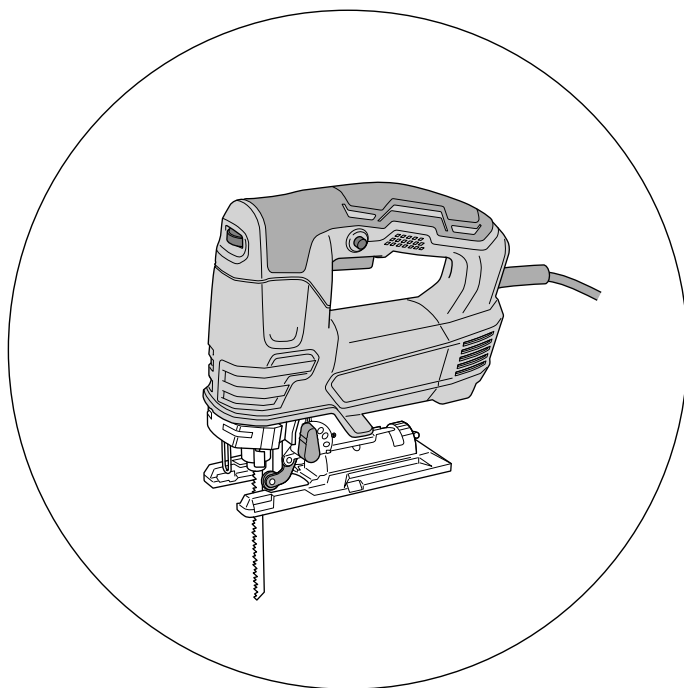

保留备用  
Keep for future reference



使用说明书  
Handling instructions



## 目次

电动工具通用安全警告 .....	2	作业之前.....	7
电动曲线锯安全警告.....	4	切割.....	10
其它安全警告.....	4	关于不锈钢板的切割.....	13
符号.....	5	锯片的选择.....	13
零件名称.....	5	卡住内六角扳手.....	14
规格.....	6	连接到清洁剂.....	14
标准附件.....	6	维护和检查.....	15
用途.....	6	选择附件.....	16

## 电动工具通用安全警告

### ⚠ 警告！

阅读所有警告和所有说明。

不遵照以下警告和说明会导致电击、着火和 / 或严重伤害。

保存所有警告和说明书以备查阅。

在所有下列的警告中术语“电动工具”指市电驱动(有线)电动工具或电池驱动(无线)电动工具。

#### 1) 工作场地的安全

- a) 保持工作场地清洁和明亮。  
混乱和黑暗的场地会引发事故。
- b) 不要在易爆环境，如有易燃液体、气体或粉尘的环境下操作电动工具。  
电动工具产生的火花会点燃粉尘或气体。
- c) 让儿童和旁观者离开后操作电动工具。  
注意力不集中会使操作者失去对工具的控制。

#### 2) 电气安全

- a) 电动工具插头必须与插座相配。绝不能以任何方式改装插头。  
需接地的电动工具不能使用任何转换插头。  
未经改装的插头和相配的插座将减少电击危险。
- b) 避免人体接触接地表面，如管道、散热片和冰箱。  
如果你身体接地会增加电击危险。
- c) 不得将电动工具暴露在雨中或潮湿环境中。  
水进入电动工具将增加电击危险。
- d) 不得滥用电线。绝不能用电线搬运、拉动电动工具或拔出其插头。使电线远离热源、油、锐边或运动部件。  
受损或缠绕的软线会增加电击危险。

- e) 当在户外使用电动工具时，使用适合户外使用的外接软线。  
适合户外使用的软线将减少电击危险。
- f) 如果在潮湿环境下操作电动工具是不可避免的，应使用剩余电流动作保护器（RCD）。  
使用RCD可减小电击危险。

### 3) 人身安全

- a) 保持警觉，当操作电动工具时关注所从事的操作并保持清醒。当你感到疲倦，或在有药物、酒精或治疗反应时，不要操作电动工具。  
在操作电动工具时瞬间的疏忽会导致严重人身伤害。
- b) 使用个人防护装置。始终佩戴护目镜。  
安全装置，诸如适当条件下使用防尘面具、防滑安全鞋、安全帽、听力防护等装置能减少人身伤害。
- c) 防止意外起动。确保开关在连接电源和 / 或电池盒、拿起或搬运工具时处于关断位置。  
手指放在已接通电源的开关上或开关处于接通时插入插头可能会导致危险。
- d) 在电动工具接通之前，拿掉所有调节钥匙或扳手。  
遗留在电动工具旋转零件上的扳手或钥匙会导致人身伤害。
- e) 手不要伸展得太长。时刻注意立足点和身体平衡。  
这样在意外情况下能很好地控制电动工具。
- f) 着装适当。不要穿宽松衣服或佩戴饰品。让衣服、手套和头发远离运动部件。  
宽松衣服、佩饰或长发可能会卷入运动部件中。
- g) 如果提供了与排屑、集尘设备连接用的装置，要确保它们连接完好且使用得当。  
使用这些装置可减少尘屑引起的危险。

### 4) 电动工具使用和注意事项

- a) 不要滥用电动工具，根据用途使用适当的电动工具。  
选用适当设计的电动工具会使你工作更有效、更安全。
- b) 如果开关不能接通或关断工具电源，则不能使用该电动工具。  
不能用开关来控制的电动工具是危险的且必须进行修理。
- c) 在进行任何调节、更换附件或贮存电动工具之前，必须从电源上拔掉插头和 / 或使电池盒与工具脱开。  
这种防护性措施将减少工具意外起动的危险。
- d) 将闲置不用的电动工具贮存在儿童所及范围之外，并且不要让不熟悉电动工具或对这些说明不了解的人操作电动工具。  
电动工具在未经培训的用户手中是危险的。

## 中文

- e) 保养电动工具。检查运动件是否调整到位或卡住，检查零件破损情况和影响电动工具运行的其他状况。如有损坏，电动工具应在使用前修理好。许多事故由维护不良的电动工具引发。
- f) 保持切削刀具锋利和清洁。  
保养良好的有锋利切削刃的刀具不易卡住而且容易控制。
- g) 按照使用说明书，考虑作业条件和进行的作业来使用电动工具、附件和工具的刀头等。  
将电动工具用于那些与其用途不符的操作可能会导致危险。

### 5) 维修

- a) 将你的电动工具送交专业维修人员，使用同样的备件进行修理。  
这样将确保所维修的电动工具的安全性。

## 注意！

不可让儿童和体弱人士靠近工作场所。

应将不使用的工具存放在儿童和体弱人士接触不到的地方。

## 电动曲线锯安全警告

1. 当在切削附件有可能碰到暗线或自身电线的场所进行操作时，只能通过绝缘握持面来握住电动工具。  
切削附件碰到带电导线可能会使电动工具的外露金属零件带电并使操作者发生电击危险。
2. 请使用夹钳或其他切实可行的方法来固定和支撑工件，将其固定到稳定的工作台上。  
用手抓住工件或用身体抵住工件并不稳定，可能会导致工件失控。

## 其它安全警告

1. 该曲线锯使用高功率的电动机。如果机器以低速持续使用，则电动机被加载一个额外的负载，并可能导致电动机卡死。经常对该电动工具进行操作以防止在作业中锯片被材料卡住。经常调整锯片速度以进行平滑的切割。
2. 切勿在工作中或刚刚结束工作时触摸锯条，因为在工作中锯条会变得很热，触摸其将会造成严重的烫伤。
3. 始终牢牢握住电动工具手柄。请务必拿紧该电动工具的把手和前盖，否则产生的反作用力可能会导致不正确的或甚至危险的操作。

4. 作业中产生的碎屑  
在正常作业中所产生的碎屑可能影响作业者的健康。请采取下列任何一种措施。
- 穿带防尘面具
  - 使用外部集尘设备
- 当使用外部集尘设备时，将外部集尘设备上的软管连接到附加器。
5. 使用过程中，请勿触碰刀具的金属部分。
6. RCD  
推荐始终使用额定剩余电流为 30mA 以下的剩余电流动作保护器。

## 符号

### 警告！

如下所示的符号用于本机。使用前请务必理解其含意。

	为降低伤害风险，用户必须阅读使用说明书	$n_0$	无负荷速度
V	额定电压	---/min	每分钟转动或往复次数
A	电流		II 类工具
W	瓦		

## 零件名称



图 1

## 规格

电压	220 V ~
输入功率	705 W
最大锯深	木材 90 mm 软钢 10 mm
空载转速	850 - 3000 /min
冲程	26 mm
最小切割半径	25 mm
重量 (不含线缆)	2.2 kg

## 标准附件

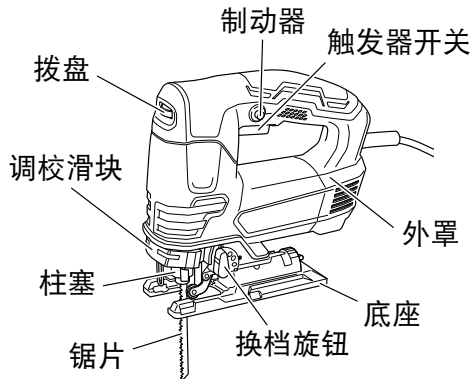
除了主机 (1 台) 外, 产品包中还包括表中所列的附件。

锯片 (No. 41) 一般木材 : 10 - 65 mm		1
内六角扳手		1

## 用途

- 切割各类木材及钻孔切割
- 切割软钢板, 铝板及铜板
- 切割合成树脂, 如酚醛树脂及氯乙烯
- 切割薄而软的建筑材料
- 切割不锈钢板 (使用 No. 97 锯片)

## 作业之前

### 1. 电源

确认所使用的电源与工具铭牌上标示的规格是否相符。

### 2. 电源开关

确认电源开关是否切断。若电源开关接通，则插头插入电源插座时电动工具将出其不意地立刻转动，从而招致严重事故。

### 3. 延伸线缆

若作业场所移到离开电源的地点，应使用容量足够、铠装合适的延伸线缆。延伸线缆要尽可能地短些。

### 4. 检查插座

如果插头插入插座后非常松动，就必须对插座进行修理。

联系持证电工，进行妥善修理。

如果使用这样的问题插座，可能会引起过热现象，进而造成严重危害。

### 5. 确认环境条件

确认工作场所条件合适，且符合规定的预防措施。

### 6. 更换锯片

## 警告！

○ 在更换锯片时，请务必关闭开关，从插座拔出插头。

## 注意！

○ 请勿在活塞移动时打开调校滑块。

○ 使用后切勿立即触碰锯片。金属很热，容易烫伤皮肤。

(1) 按照箭头所指示的方向拉动调校滑块。(图 2-I)

(2) 拉动调校滑块的同时，插入锯片直至锯片固定器端部外口卡住。(图 2-II)

(3) 松开调校滑块。(图 2-III)



图 2-I

图 2-II

图 2-III

# 中文

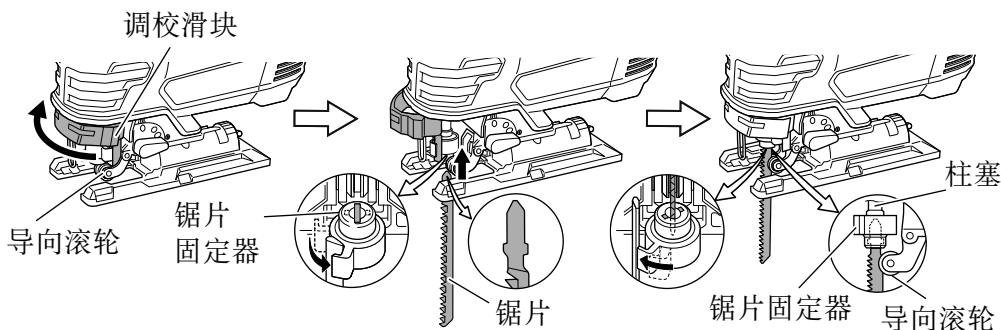
注：

- 确保锯片的伸出部分确实地插入锯片固定器。
- 确保锯片位于轱子的凹槽内。(图 3)

## 7. 开关的操作 (图 4)

拉动触发器开关时将激活，松开时将断开。

若要进行持续运转，请将触发器开关拉动到位并按下制动器。

若要取消持续运转，请再一次将触发器开关拉动到位直至制动器被松开，然后松开触发器开关。

## 8. 调整锯片作业速度

该曲线锯装备了电子控制电路，可进行实时速度控制。调整速度时，转动图 5 所示的拨盘。当拨盘调至“1”时，曲线锯以最低速度作业 (850 /min)。当拨盘调至“6”时，曲线锯以最高速度作业 (3000 /min)。根据将要切割的材料及工作效率调整速度。

## 注意！

以低速（拨盘设置：1 或 2）作业时，请勿切割厚度超过 8 毫米的木材或厚度超过 1 毫米的金属。

## 9. 调整轨道作业

- (1) 该曲线锯采用轨道作业，对锯片进行前后及上下移动。将图 6 所示的转换旋钮调至“0”可停止轨道作业（锯片将仅进行上下移动）。轨道作业可在从“0”到“III”4 个等级中选择。
- (2) 对于硬质材料如钢板等，减少轨道作业；对于软质材料如木材，塑料等，增多轨道作业以提高工作效率。如需对材料进行精密切割，减少轨道作业。

## 10. 切割不锈钢板

该曲线锯可使用 No. 97 锯片（单独出售）对不锈钢板进行切割。仔细阅读“关于不锈钢板的切割”，了解正确作业方法（第 13 页）。



图 3



图 4

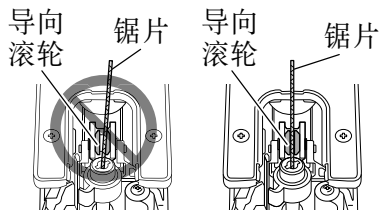

图 5

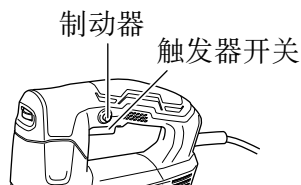

图 6

## 11. 碎屑防护头（单独出售）

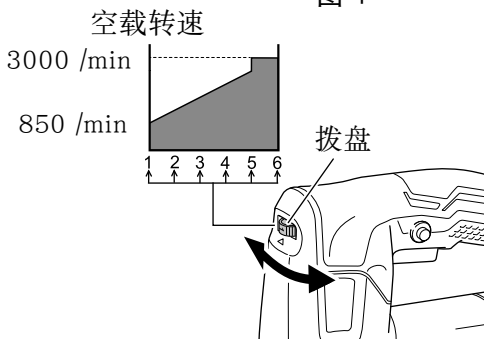
在切割木质材料时使用碎屑防护头可减少切割表面的碎屑。

- (1) 使用内六角扳手松开附在底座上的底座螺栓，并将底座充分向前移动（图 7）。
- (2) 将碎片防护头插到底座上的适当位置，并且完全插入。（图 8）
- (3) 安装锯片。
- (4) 将底座充分向后推动，并拧紧位于底座底部的底座螺栓，固定底座。

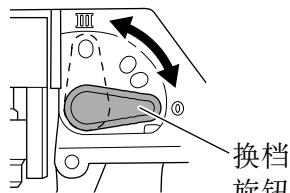
注：

碎屑防护头只能用于在直角（底座倾斜度为 0 度）时沿直线切割。

## 12. 副底座（单独出售）

用于进行例如弧形和圆形等曲线切割。通过消除在底座后部和材料之间可能出现的钩丝，可以很简单地完成任任务。在将副底座钩在底座端部后，将副底座插入到位。

若要拆下，请向上拉。（图 9）

注：

装上副底座后，锯片在被切割材料上的伸出部分会缩短 3 mm。将锯片下移至最低点时，请检查并确保其伸出材料。

## 13. 底座板

松开底座上的四颗螺钉，拆下底座板。装回后，重新拧紧四颗螺钉。（图 10）



图 7



图 8

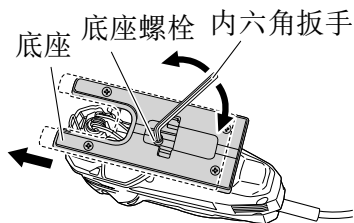

图 9

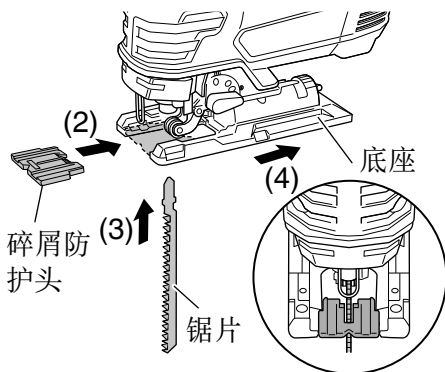

图 10

## 14. 准备工作台 (图 11)

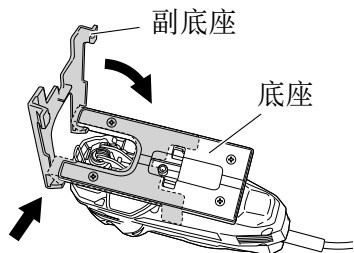
鉴于锯片会延伸超出材料下表面，因此在切割时应将材料放在工作台上。如果将方块用作工作台，请选择水平地面以确保其确实稳定。不稳定工作台会导致危险操作。

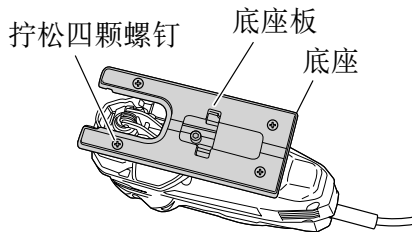

图 11

## 注意！

为了避免可能发生事故，请始终确保切割后剩余材料部分牢固地固定或保持在原位。

## 切割

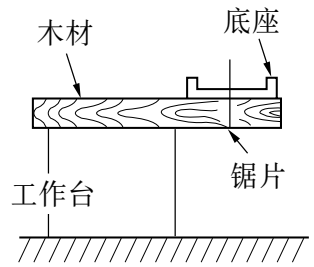
## 注意！

为防止锯片撞出，损坏或对柱塞造成额外的磨损，锯时请确保将底座板贴住工作材料。

### 1. 直线切割

当以直线切割时，首先划一条标准线，并顺著线锯。使用导架（单独出售）可帮助您精确地以直线切割。

- (1) 使用内六角扳手松开附在底座上的底座螺栓。（第 9 页的图 7）
- (2) 将底座充分向前移动（第 9 页的图 7）再次上紧底座螺栓。
- (3) 将导架穿过导底座上的导架孔，上紧 M5 螺栓。（图 12）
- (4) 将轨道位置设为“0”。

### 注：

为在使用导架时确保精确地切割（图 12），总是将轨道位置设为“0”。

### 2. 曲线切割

当切割一个小的弧形时，降低机器的喂料速度。如向机器的喂料速度过快，可能导致锯片损坏。

将轨道位置设为“0”。



图 12

### 3. 圆形或圆弧切割

导架同样可用于圆形切割。

在同样以上述方式安装导架后，将螺钉或螺栓从导架上的孔旋入材料内并用作切割的轴心。（图 13）。

将轨道位置设为“0”。

注：

○ 圆形切割时必须保证锯片大致与底座的下表面垂直。

○ 通过使用副底座可以轻松完成圆形切割。副底座（安装方法请参考第 9 页。）

### 4. 切割金属材料（图 14）

(1) 调整速度。拨到刻度“3”与“4”之间。

(2) 将轨道位置设为“0”或图中所示位置。

注：

总是使用适当的切割液（锭子油、肥皂水等）。当切割液不合适时，将油脂涂在切割材料的背面。

### 5. 钻孔切割

(1) 使用内六角扳手松开附在底座上的底座螺栓。（第 9 页的图 7）

(2) 将底座充分向前移动，再次上紧底座螺栓。（第 9 页的图 7）

(3) 将轨道位置设为“0”。

〈在木材上〉（图 15）

使锯片的方向与木材的切面一致，逐步切割直至在木材的中心切割出一个空孔来。



图 13



图 14

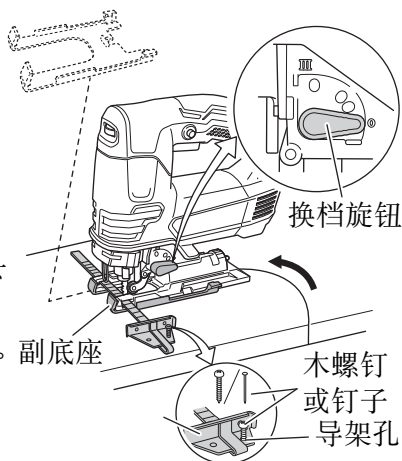

图 15

〈在其他材料上〉(图 16)

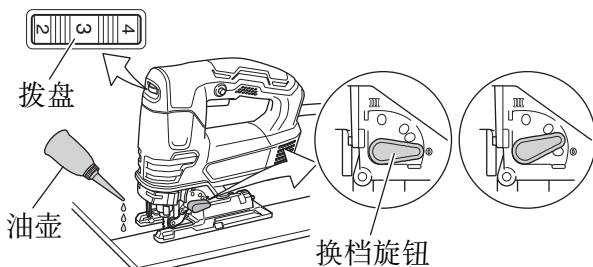
在除了木材的其他材料上切割空孔时,首先使用钻子或类似的工具钻出孔来,再进行切割。

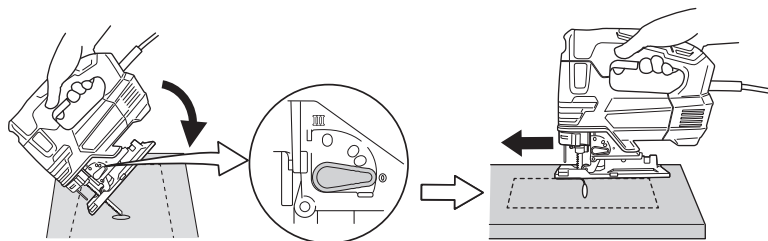

图 16

## 6. 角度切割

底座可向两边旋转至最大  $45^\circ$  以进行角度切割。(图 17)

(1) 使用内六角扳手松开附在底座上的底座螺栓,并将底座充分向前移动。(第 9 页的图 7)

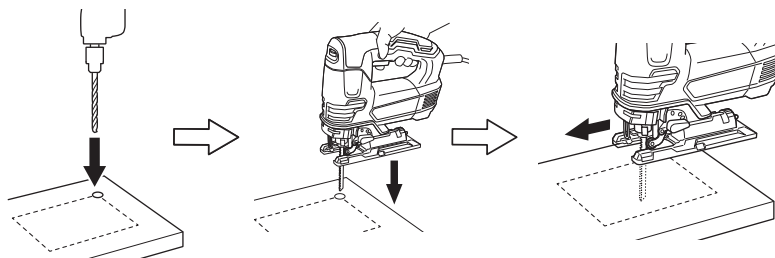
(2) 利用后表面上的 [▽] 符号,调整底座半圆片的刻度(从 0 度到 45, 每次增加 15 度)。(图 18)

(3) 再次上紧底座螺栓。(第 9 页的图 7)

(4) 将轨道位置设为“0”-“III”。

注:

使用碎屑盖或集尘器时不能进行角度切割。



图 17



图 18

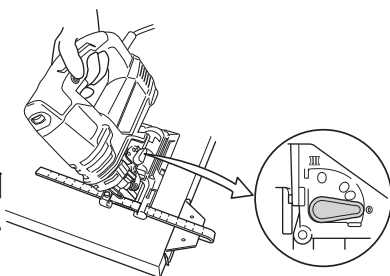

## 关于不锈钢板的切割

当使用 No.97 锯片（单独出售）时，可以切割不锈钢板。  
注意按照以下流程调整设备。

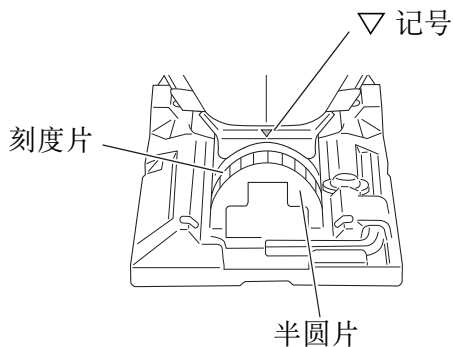
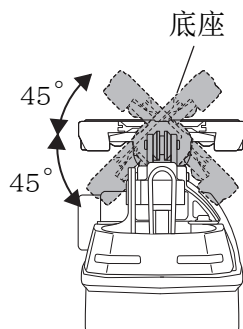
### 注意！

为防止锯片撞出，损坏或对柱塞造成额外的磨损，锯时请确保将底座板贴住工作材料。

在切割不锈钢板时，请如下调整设备：

#### 1. 调整速度

锯片	材料厚度	拨盘刻度
No. 97	1.5 – 2.5 mm	“2”与“3”之间的中间刻度

#### 注：

拨盘刻度读数仅为参考。速度越快，材料切割越快。但这种情况下锯片的使用寿命将被缩短。当速度过低时，切割将耗时较长，而锯片的使用寿命将被延长。请按意愿进行调整。

#### 2. 将轨道位置设为“0”

#### 注：

切割时请使用切割液（油质切割液）以延长锯片的使用寿命。



图 19

## 锯片的选择

### ○ 附件锯片

为确保最高的作业效率及最好的作业结果，选择最适合切割材料的类型与厚度的适当的锯片是十分重要的。一种锯片被作为标准附件提供。每片锯片的脊部附近刻有锯片号。

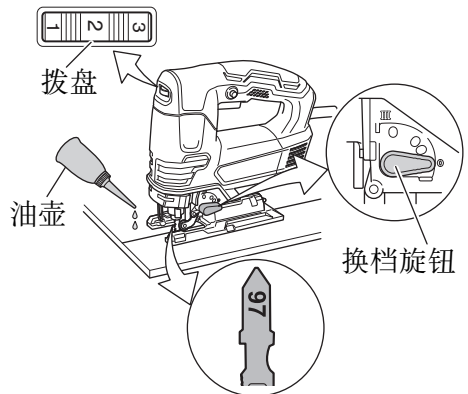
## 卡住内六角扳手

可以卡住底座上的内六角扳手。(参看图 20)



图 20

## 连接到清洁器

通过集尘附加器 (单独出售) 和附加器 (单独出售) 与清洁器 (单独出售) 相连接, 能够收集大多数的尘屑。

- (1) 使用内六角扳手松开附在底座上的底座螺栓。(第 9 页的图 7)
- (2) 将底座充分向前移动, 再次上紧底座螺栓。(第 9 页的图 7)
- (3) 通过附加器连接上集尘附加器。(图 21)
- (4) 连接附加器与清洁器的接头。(图 21)
- (5) 将清洁器插入底座的后孔直至勾脚插入槽口。(图 22)
- (6) 按住勾脚以取下集尘附加器。

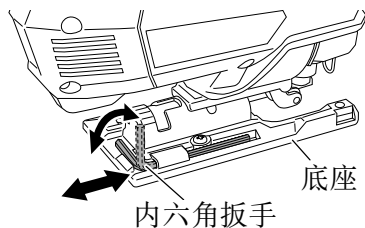

图 21



图 22

## 维护和检查

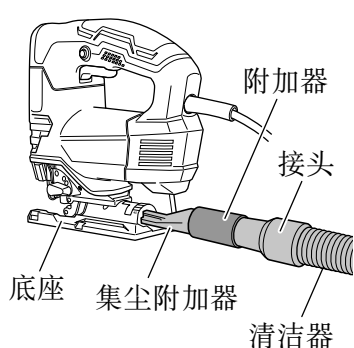
### 警告！

在维护和检查期间，一定要“切断”电源，并将插座上的插头拔掉。

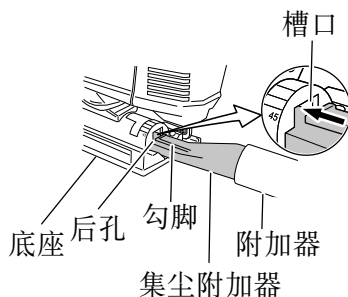
#### 1. 检查锯片

继续使用钝化的或损坏的锯片将导致切割效率下降，并可能导致电动机超载。一发现额外的切痕，请立即更换锯片。

#### 2. 检查安装螺钉

要经常检查安装螺钉是否紧固妥善。若发现螺钉松了，应立即重新扭紧，否则会导致严重的事故。

#### 3. 电动机的维护

电动机绕线是电动工具的“心脏部”应仔细检查有无损伤，是否被油液或水沾湿。

#### 4. 检查炭刷

为了保证长期安全操作和防止触电，必须仅由经授权的HiKOKI维修服务中心检查和更换炭刷。

#### 5. 更换电源线

如果需要更换电源线，则必须由此代理的生产厂商进行操作，以免发生危险。

## 选择附件

有关详细信息请联系HiKOKI授权服务中心。

锯片

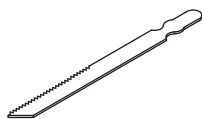

No.	产品编号
41	879357
97	963400

内六角扳手



产品编号：944458

导架

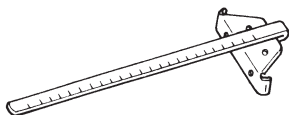

产品编号：879391

碎屑防护头



产品编号：338997

集尘附加器

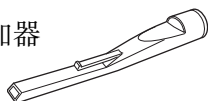

产品编号：370492

底座板

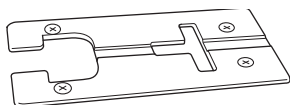

(钢) 产品编号：375855

(氟) 产品编号：339012

副底座

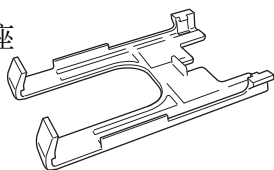

产品编号：339018

塑料箱

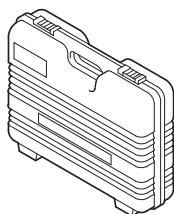

产品编号：337883

## CONTENTS

GENERAL POWER TOOL SAFETY WARNINGS .....	17
JIG SAW SAFETY WARNINGS.....	19
ADDITIONAL SAFETY WARNINGS.....	20
SYMBOLS .....	20
NAME OF PARTS.....	21
SPECIFICATIONS.....	21
STANDARD ACCESSORIES .....	21
APPLICATIONS.....	21
PRIOR TO OPERATION.....	22
CUTTING.....	25
CONCERNING CUTTING OF STAINLESS STEEL PLATES .....	28
SELECTION OF BLADES .....	28
HOUSING THE HEXAGONAL BAR WRENCH .....	29
CONNECTING WITH CLEANER.....	29
MAINTENANCE AND INSPECTION .....	30
SELECTING ACCESSORIES.....	31

## GENERAL POWER TOOL SAFETY WARNINGS

### WARNING

**Read all safety warnings and all instructions.**

*Failure to follow the warnings and instructions may result in electric shock, fire and/or serious injury.*

**Save all warnings and instructions for future reference.**

*The term “power tool” in the warnings refers to your mains-operated (corded) power tool or battery-operated (cordless) power tool.*

- 1) **Work area safety**
  - a) **Keep work area clean and well lit.**  
*Cluttered or dark areas invite accidents.*
  - b) **Do not operate power tools in explosive atmospheres, such as in the presence of flammable liquids, gases or dust.**  
*Power tools create sparks which may ignite the dust or fumes.*
  - c) **Keep children and bystanders away while operating a power tool.**  
*Distractions can cause you to lose control.*
- 2) **Electrical safety**
  - a) **Power tool plugs must match the outlet.**  
**Never modify the plug in any way.**  
**Do not use any adapter plugs with earthed (grounded) power tools.**  
*Unmodified plugs and matching outlets will reduce risk of electric shock.*

## English

- b) **Avoid body contact with earthed or grounded surfaces, such as pipes, radiators, ranges and refrigerators.**  
*There is an increased risk of electric shock if your body is earthed or grounded.*
- c) **Do not expose power tools to rain or wet conditions.**  
*Water entering a power tool will increase the risk of electric shock.*
- d) **Do not abuse the cord. Never use the cord for carrying, pulling or unplugging the power tool.**  
**Keep cord away from heat, oil, sharp edges or moving parts.**  
*Damaged or entangled cords increase the risk of electric shock.*
- e) **When operating a power tool outdoors, use an extension cord suitable for outdoor use.**  
*Use of a cord suitable for outdoor use reduces the risk of electric shock.*
- f) **If operating a power tool in a damp location is unavoidable, use a residual current device (RCD) protected supply.**  
*Use of an RCD reduces the risk of electric shock.*

### 3) Personal safety

- a) **Stay alert, watch what you are doing and use common sense when operating a power tool.**  
**Do not use a power tool while you are tired or under the influence of drugs, alcohol or medication.**  
*A moment of inattention while operating power tools may result in serious personal injury.*
- b) **Use personal protective equipment. Always wear eye protection.**  
*Protective equipment such as dust mask, non-skid safety shoes, hard hat, or hearing protection used for appropriate conditions will reduce personal injuries.*
- c) **Prevent unintentional starting. Ensure the switch is in the off position before connecting to power source and/or battery pack, picking up or carrying the tool.**  
*Carrying power tools with your finger on the switch or energising power tools that have the switch on invites accidents.*
- d) **Remove any adjusting key or wrench before turning the power tool on.**  
*A wrench or a key left attached to a rotating part of the power tool may result in personal injury.*
- e) **Do not overreach. Keep proper footing and balance at all times.**  
*This enables better control of the power tool in unexpected situations.*
- f) **Dress properly. Do not wear loose clothing or jewellery. Keep your hair, clothing and gloves away from moving parts.**  
*Loose clothes, jewellery or long hair can be caught in moving parts.*
- g) **If devices are provided for the connection of dust extraction and collection facilities, ensure these are connected and properly used.**  
*Use of dust collection can reduce dust-related hazards.*

### 4) Power tool use and care

- a) **Do not force the power tool. Use the correct power tool for your application.**  
*The correct power tool will do the job better and safer at the rate for which it was designed.*

- b) **Do not use the power tool if the switch does not turn it on and off.**  
*Any power tool that cannot be controlled with the switch is dangerous and must be repaired.*
- c) **Disconnect the plug from the power source and/or the battery pack from the power tool before making any adjustments, changing accessories, or storing power tools.**  
*Such preventive safety measures reduce the risk of starting the power tool accidentally.*
- d) **Store idle power tools out of the reach of children and do not allow persons unfamiliar with the power tool or these instructions to operate the power tool.**  
*Power tools are dangerous in the hands of untrained users.*
- e) **Maintain power tools. Check for misalignment or binding of moving parts, breakage of parts and any other condition that may affect the power tool's operation.**  
**If damaged, have the power tool repaired before use.**  
*Many accidents are caused by poorly maintained power tools.*
- f) **Keep cutting tools sharp and clean.**  
*Properly maintained cutting tools with sharp cutting edges are less likely to bind and are easier to control.*
- g) **Use the power tool, accessories and tool bits etc. in accordance with these instructions, taking into account the working conditions and the work to be performed.**  
*Use of the power tool for operations different from those intended could result in a hazardous situation.*

## 5) Service

- a) **Have your power tool serviced by a qualified repair person using only identical replacement parts.**  
*This will ensure that the safety of the power tool is maintained.*

## CAUTION

Keep children and infirm persons away.

When not in use, tools should be stored out of reach of children and infirm persons.

## JIG SAW SAFETY WARNINGS

1. **Hold power tool by insulated gripping surfaces, when performing an operation where the cutting accessory may contact hidden wiring or its own cord.**  
Cutting accessory contacting a "live" wire may make exposed metal parts of the power tool "live" and could give the operator an electric shock.
2. **Use clamps or another practical way to secure and support the workpiece to a stable platform.**  
Holding the workpiece by hand or against your body leaves it unstable and may lead to loss of control.

## ADDITIONAL SAFETY WARNINGS



1. This Jig saw employs a high-power motor. If the machine is used continuously at low speed, an extra load is applied to the motor which can result in motor seizure. Always operate the power tool so that the blade is not caught by the material during operation. Always adjust the blade speed to enable smooth cutting.
2. Do not touch the blade during or immediately after operation. The blade becomes very hot during operation and could cause serious burns.
3. Always hold the handle of the power tool firmly. Otherwise the counterforce produced may result in inaccurate and even dangerous operation.
4. Dust produced in operation  
The dust produced in normal operation may affect the operator's health. Either of following way is recommended.
  - a) Wear a dust mask
  - b) Use external dust collection equipment.

When using the external dust collection equipment, connect the adapter with the hose from external dust collection equipment.
5. During use, do not touch the metal portion of the tool.
6. RCD  
The use of a residual current device with a rated residual current of 30 mA or less at all times is recommended.

## SYMBOLS

### WARNING

The following show symbols used for the machine. Be sure that you understand their meaning before use.

	To reduce the risk of injury, user must read instruction manual.	$n_0$	No-load speed
V	Rated voltage	---/min	revolutions or reciprocations per minute
A	Current		Class II tool
W	Watt		

## NAME OF PARTS

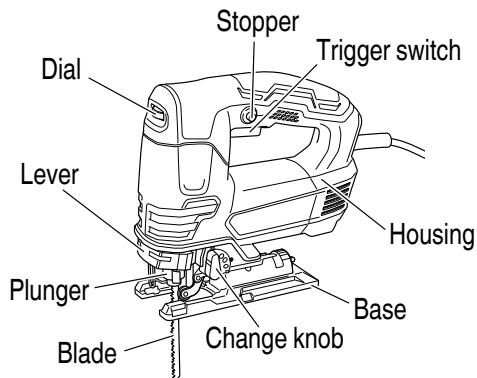



Fig. 1

## SPECIFICATIONS

Voltage	220 V ~
Power Input	705 W
Max. Cutting Depth	Wood 90 mm Mild Steel 10 mm
No-load speed	850 – 3000 /min
Stroke	26 mm
Min. Cutting Radius	25 mm
Weight (without cord)	2.2 kg

## STANDARD ACCESSORIES

In addition to the main unit (1 unit), the package contains the accessories listed in the below.

Blades (No. 41) General lumber: 10 – 65 mm		1
Hexagon bar wrench		1

## APPLICATIONS

- Cutting various lumber and pocket cutting
- Cutting mild steel plate, aluminum plate, and copper plate
- Cutting synthetic resins, such as phenol resin and vinyl chloride
- Cutting thin and soft construction materials
- Cutting stainless steel plate (with No. 97 blade)

## PRIOR TO OPERATION

1. Power source  
Ensure that the power source to be utilized conforms to the power requirements specified on the product nameplate.
2. Power switch  
Ensure that the power switch is in the OFF position. If the plug is connected to a receptacle while the power switch is in the ON position, the power tool will start operating immediately, which could cause a serious accident.
3. Extension cord  
When the work area is removed from the power source, use an extension cord of sufficient thickness and rated capacity. The extension cord should be kept as short as practicable.
4. Check the receptacle  
If the receptacle only loosely accepts the plug, the receptacle must be repaired. Contact a licensed electrician to make appropriate repairs. If such a faulty receptacle is used, it may cause overheating, resulting in a serious hazard.
5. Confirming condition of the environment  
Confirm that the work site is placed under appropriate conditions conforming to prescribed precautions.
6. Changing blades

## WARNING

- **Be sure to switch power OFF and disconnect the plug from the receptacle when changing blades.**

## CAUTION

- **Do not open the lever when plunger is moving.**
  - **Never touch the blade immediately after use. The metal is hot and can easily burn your skin.**
- (1) Pull the lever in the direction indicated by the arrow. (Fig. 2-I)
  - (2) With the lever pulled, insert the blade until it butts against the outlet of the blade holder tip. (Fig. 2-II)
  - (3) Release the lever. (Fig. 2-III).

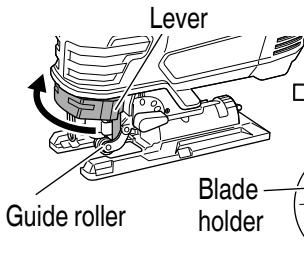

Fig. 2-I

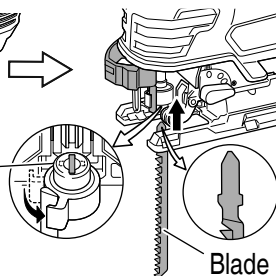

Fig. 2-II

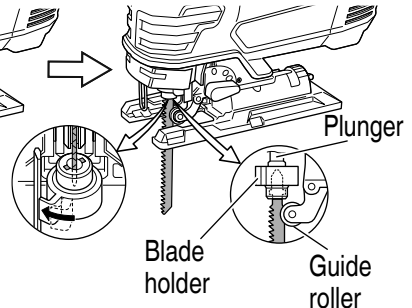
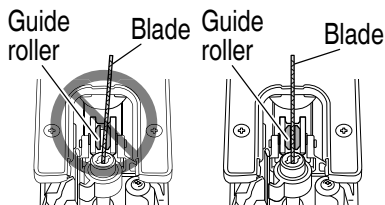

Fig. 2-III

**NOTE**

- Confirm the protrusions of blade inserted to the blade holder surely.
  - Confirm the blade located between the groove of roller. (**Fig. 3**).
7. Switch operation (**Fig. 4**)  
The trigger switch will activate when pulled and will deactivate when released.  
For continuous operation, pull the trigger switch in all the way and press the stopper.  
To cancel continuous operation, once again pull the trigger switch in all the way until the stopper is freed, and then release the trigger switch.

**Fig. 3**

8. Adjusting the blade operating speed  
The jig saw is equipped with the electric control circuit which enables stepless speed control. To adjust the speed, turn the dial shown in **Fig. 5**. When the dial is set to "1", the jig saw operates at the minimum speed (850 /min). When the dial set to "6", the jig saw operates at the maximum speed (3000 /min). Adjust the speed according to the material to be cut and working efficiency.

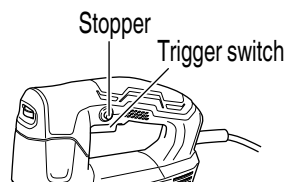
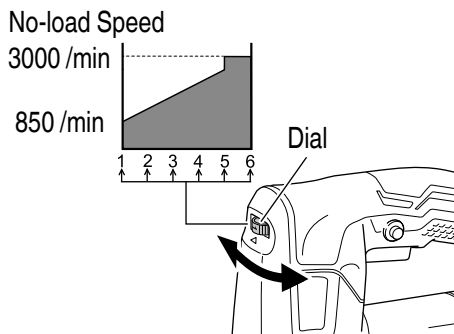
**Fig. 4****Fig. 5****CAUTION**

**At low speed (dial setting: 1 or 2) do not cut a wood with a thickness of more than 8 mm or metal with a thickness of more than 1 mm.**

9. Adjusting the orbital operation  
(1) This Jig Saw employs orbital operation which moves the blade back and forth, as well as up and down. Set the change knob shown in **Fig. 6** to "0" to eliminate the orbital operation (the blade moves only up and down). The orbital operation can be selected in 4 steps from "0" to "III".  
(2) For the hard material, such as a steel plate, etc., decrease the orbital operation. For the soft material, such as lumber, plastic, etc., increase the orbital operation to increase work efficiency. To cut the material accurately, decrease the orbital operation.
10. Cutting stainless steel plates  
This Jig Saw can cut stainless steel plates by using No. 97 blade (sold separately). Carefully read "Concerning cutting of stainless steel plates" for proper operation (**on page 28**).

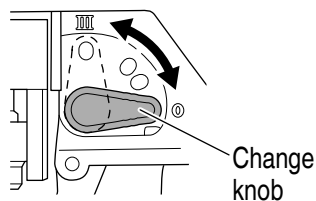
**Fig. 6**

## English

11. Splinter guard (sold separately)  
Using the splinter guard when cutting wood materials will reduce splintering of cut surfaces.

- (1) Loosen the base bolt by hexagonal bar wrench attached on base, and move the base fully forward (**Fig. 7**).
- (2) Insert the splinter guard in the space on the base, and push it completely. (See **Fig. 8**)
- (3) Attach the blade.
- (4) Push the base all the way to the back position, and tighten the base bolts located at the bottom of the base to secure the base.

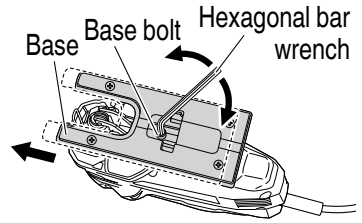

**Fig. 7**

### NOTE

The splinter guard can only be used to cut along a straight line at a right angle (base incline 0 degrees).

12. Sub base (sold separately)  
Used for curved cutting of pieces such as arcs and circles. Makes the task easier by eliminating any snags that may occur between the rear of the base and the material.

Fit into position after hooking the sub base to the tip of the blade.

To detach, pull up. (**Fig. 9**)

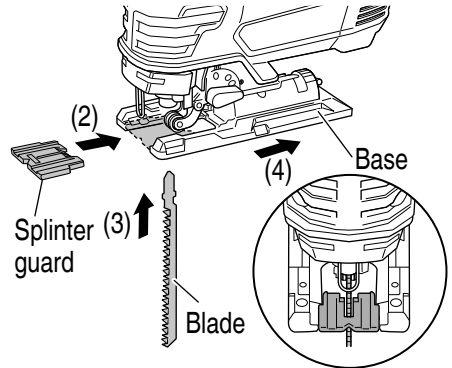
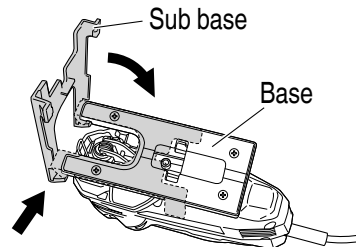

**Fig. 8**

### NOTE

When the sub base is attached, the blade's protrusion from the material being cut will be reduced by 3 mm. When the blade has been moved down to the lowest point, check to make sure that it is protruding from the material.

13. Base plate  
Unscrew the four screws on the base to enable the base plate to be removed.  
Retighten the four screws securely after reattaching. (**Fig. 10**)



**Fig. 9**

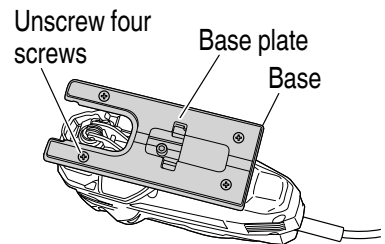

**Fig. 10**

14. Prepare a work bench (**Fig. 11**)  
 Since the blade will extend beyond the lower surface of the material, place the material on a work bench when cutting. If a square block is utilized as a work bench, select level ground to ensure it is properly stabilized. An unstable work bench will result in hazardous operation.

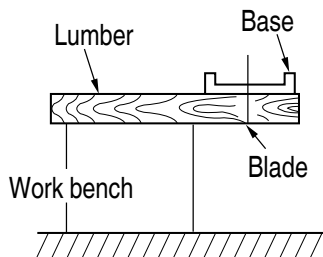

Fig. 11

## CAUTION

To avoid possible accident, always ensure that the portion of material remaining after cutting is securely anchored or held in position.

## CUTTING

### CAUTION

In order to prevent blade dislodging, damage or excessive wear on the plunger, please make sure to have surface of the base plate attached to the work piece while sawing.

1. Rectilinear cutting  
 When cutting on a straight line, first draw a marking gauge line and advance the saw along that line. Using the guide (sold separately) will make it possible to cut accurately on a straight line.
  - (1) Loosen the base bolt by hexagonal bar wrench attached on base. (**Fig. 7 on page 24**)
  - (2) Move the base fully forward (**Fig. 7 on page 24**), and tighten the base bolt again.
  - (3) Attach the guide by passing it through the attachment hole on the base and tighten the M5 bolt. (**Fig. 12**)
  - (4) Set the orbital position to "0".

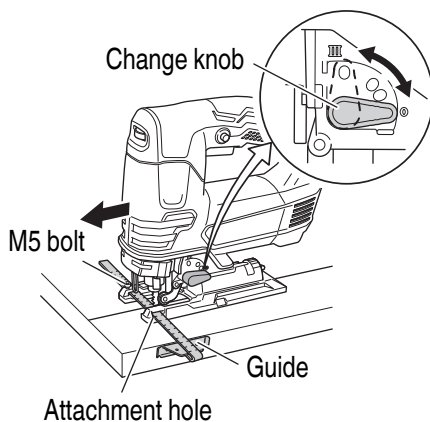

Fig. 12

### NOTE

To ensure accurate cutting when using the guide (**Fig. 12**), always set the orbital position to "0".

2. Sawing curved lines  
 When sawing a small circular arc, reduce the feeding speed of the machine. If the machine is fed too fast, it could cause the blade to break. Set the orbital position to "0".

# English

3. Cutting a circle or a circular arc  
The guide also will be helpful for circular cutting. After attaching the guide by same way noted as above, drive the nail or screw into the material through the hole on the guide, then use it for an axis when cutting. (**Fig. 13**).  
Set the orbital position to "0".

## NOTE

- Circular cutting must be done with the blade approximately vertical to the bottom surface of the base.
- Circular cutting can be done easily by using the sub base. (See **P. 24** for the attachment method.)

4. Cutting metallic materials (**Fig. 14**)

- (1) Adjust the speed dial between scales "3" and "4".
- (2) Set the orbital position to "0" or to the position indicated in the figure.

## NOTE

Always use an appropriate cutting fluid (spindle oil, soapy water, etc.). When a liquid cutting fluid is not available, apply grease to the back surface of the material to be cut.

5. Pocket cutting

- (1) Loosen the base bolt hexagonal bar wrench attached on base. (**Fig. 7 on page 24**)
- (2) Move the base fully forward, and tighten the base bolt again. (**Fig. 7 on page 24**)
- (3) Set the orbital position to "0".

<In lumber> (**Fig. 15**)

Aligning the blade direction with the grain of the wood, cut step by step until a window hole is cut in the center of the lumber.

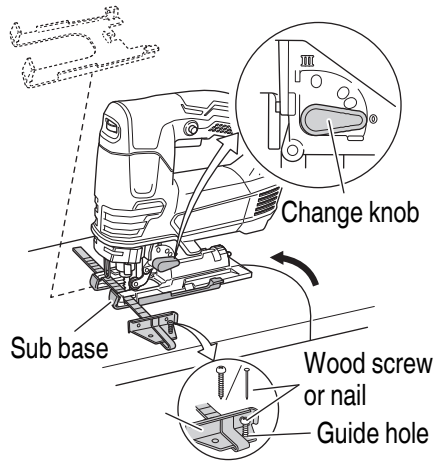

**Fig. 13**

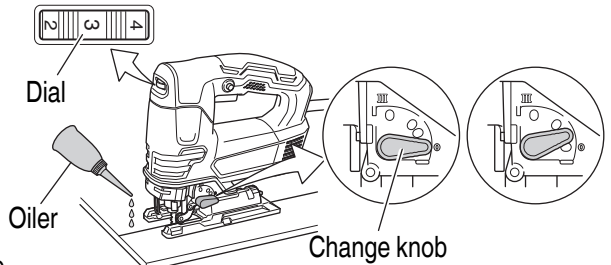

**Fig. 14**

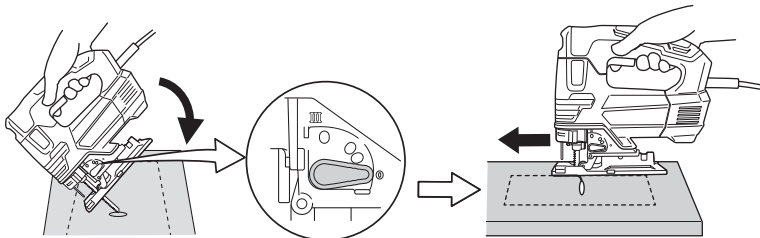

**Fig. 15**

<In other materials> (Fig. 16)

When cutting a window hole in materials other than lumber, initially bore a hole with a drill or similar tool from which to start cutting.

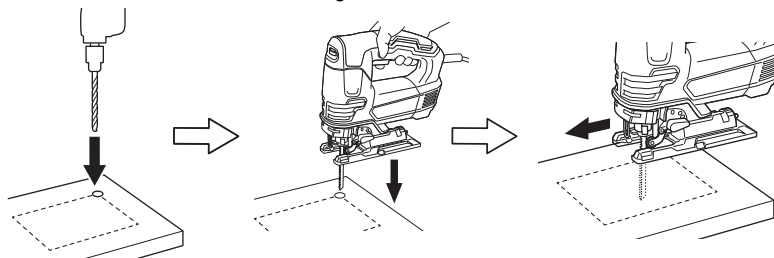

Fig. 16

6. Angular cutting

The base can be swiveled to both sides by up to 45° for angular cutting. (Fig. 17)

(1) Loosen the base bolt by hexagonal bar wrench attached on base and move the base fully forward. (Fig. 7 on page 24)

(2) Align the scale (from 0 degrees to 45 degrees by 15-degree increments) of the semi-circular part of the base with the [▽] mark on the gear cover. (Fig. 18)

(3) Tighten the base bolt again. (Fig. 7 on page 24)

(4) Set the orbital position to "0"- "III".

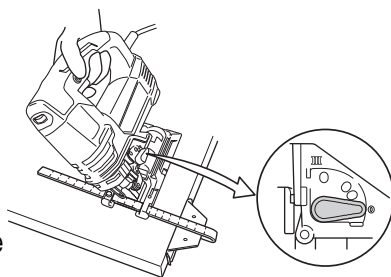

Fig. 17

NOTE

Angular cutting can not be done when adopting chip cover or dust collector.

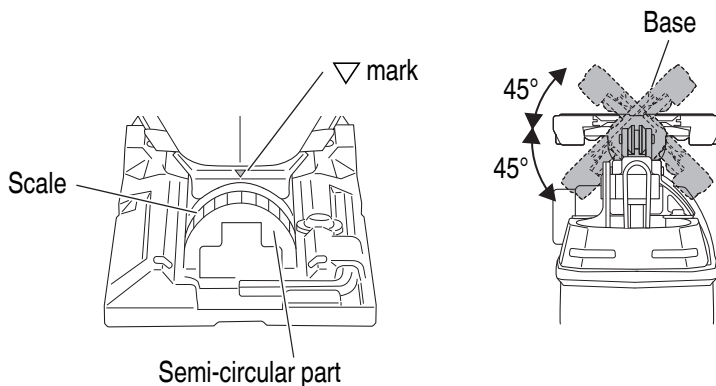

Fig. 18

## CONCERNING CUTTING OF STAINLESS STEEL PLATES

When used with the No. 97 blade (sold separately), can cut stainless steel plates.  
Note the following to adjust the unit.

### CAUTION

**In order to prevent blade dislodging, damage or excessive wear on the plunger, please make sure to have surface of the base plate attached to the work piece while sawing.**

When cutting stainless steel plates, adjust the unit as described below:

1. Adjust the speed.

Blade	Thickness of material	Dial Scale
No. 97	1.5 – 2.5 mm	Middle groove position between scales “2” and “3”

### NOTE

Dial scale reading is for reference only. The higher the speed is, the quicker the material is cut. But the service life of the blade will be reduced in this case. When the speed is too low, cutting will take longer, although the service life will be prolonged. Make adjustments as desired.

2. Set the orbital position to “0”

### NOTE

When cutting use cutting fluid (oil base cutting fluid) to prolong the blade's service life.

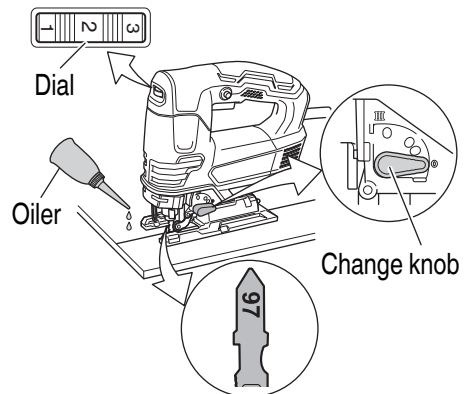

Fig. 19

## SELECTION OF BLADES

- Accessory blades

To ensure maximum operating efficiency and results, it is very important to select the appropriate blade best suited to the type and thickness of the material to be cut. One type of blade is provided as standard accessory. The blade number is engraved in the vicinity of the mounting portion of each blade.

## HOUSING THE HEXAGONAL BAR WRENCH

It is possible to house the hexagonal bar wrench on the base. (See **Fig. 20**)

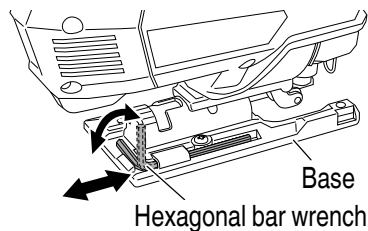
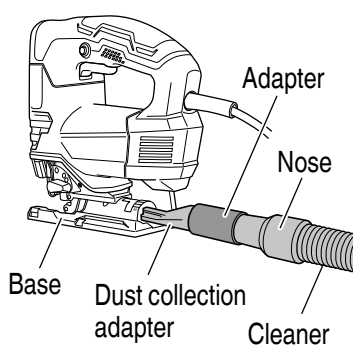

**Fig. 20**

## CONNECTING WITH CLEANER

By connecting with cleaner (sold separately) through dust collection adapter (sold separately) and adapter (sold separately), most of dust can be collected.

- (1) Loosen the base bolt hexagonal bar wrench attached on base. (**Fig. 7 on page 24**)
- (2) Move the base fully forward, and tighten the base bolt again. (**Fig. 7 on page 24**)
- (3) Connect the dust collection adapter with adapter. (**Fig. 21**)
- (4) Connect the adapter with the nose of cleaner. (**Fig. 21**)
- (5) Insert dust collection adapter into the rear hole of the base until the hook catches in the notch. (**Fig. 22**)
- (6) Press the hook to remove the dust collection adapter.



**Fig. 21**

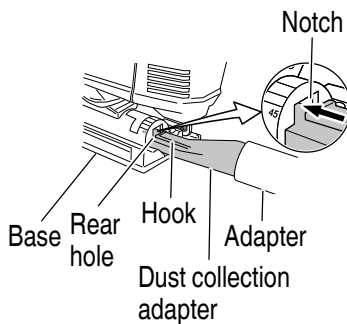

**Fig. 22**

## MAINTENANCE AND INSPECTION

### WARNING

**Be sure to switch power OFF and disconnect the plug from the receptacle during maintenance and inspection.**

1. Inspecting the blade  
Continued use of a dull or damaged blade will result in reduced cutting efficiency and may cause overloading of the motor. Replace the blade with a new one as soon as excessive abrasion is noted.
2. Inspecting the mounting screws  
Regularly inspect all mounting screws and ensure that they are properly tightened. Should any of the screws be loose, retighten them immediately. Failure to do so could result in serious hazard.
3. Maintenance of the motor  
The motor unit winding is the very “heart” of the power tool.  
Exercise due care to ensure the winding does not become damaged and/or wet with oil or water.
4. Inspecting the carbon brushes  
For your continued safety and electrical shock protection, carbon brush inspection and replacement on this tool should ONLY be performed by a HiKOKI AUTHORIZED SERVICE CENTER.
5. Replacing supply cord  
If the replacement of the supply cord is necessary, this has to be done by the manufacturer of this agent in order to avoid a safety hazard.

## SELECTING ACCESSORIES

For details contact HiKOKI Authorized Service Center.

Blades

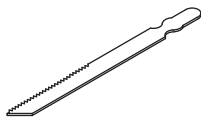

No.	Part Number
41	879357
97	963400

Hexagonal bar  
wrench



Part Number: 944458

Guide

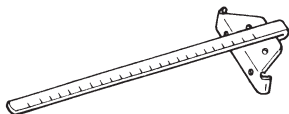

Part Number: 879391

Splinter  
guard



Part Number: 338997

Dust collection  
adapter

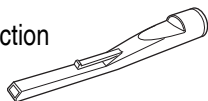

Part Number: 370492

Base plate

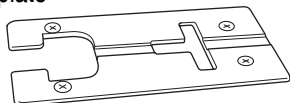

(Steel) Part Number: 375855  
(Fluorine) Part Number: 339012

Sub base

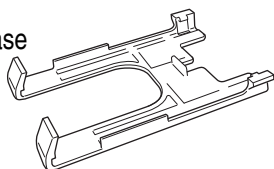

Part Number: 339018

Case

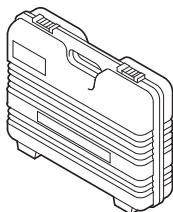

Part Number: 337883

服务中心  
高壹工机商业(上海)有限公司  
上海市闵行区召楼路3576号5幢

制造商  
福建高壹工机有限公司  
福建省福州市福兴投资区湖塘路

**Koki Holdings Co., Ltd.**

505  
编号: C99737322 F  
发行日期: 2025年 5月  
中国印刷