

HiKOKI

充电式往复锯

Cordless Reciprocating Saw

CR 36DA

中文
English

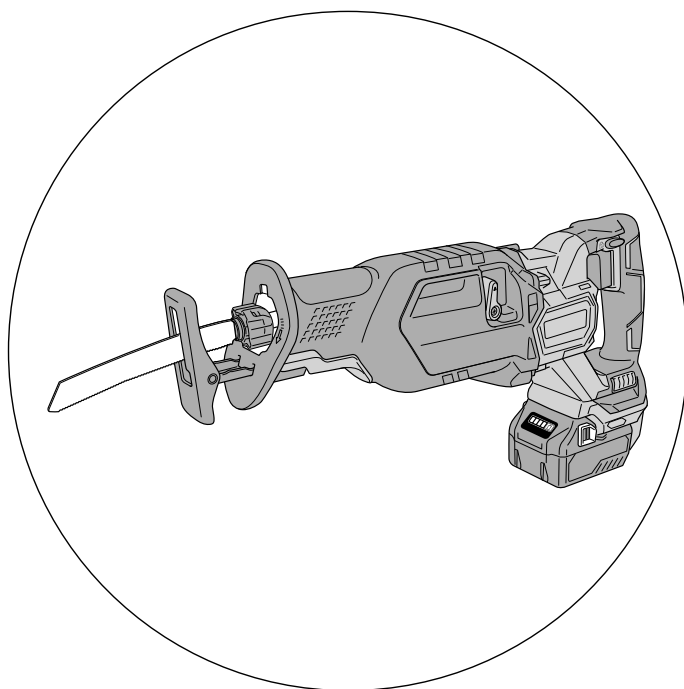

保留备用

Keep for future reference



使用说明书

Handling instructions

目次

电动工具通用安全警告.....	2	电池的拆卸 / 安装法.....	10
充电式往复锯使用注意事项.....	5	充电.....	10
锂离子电池使用注意事项.....	6	作业之前.....	13
锂离子电池运输.....	7	使用方法.....	15
USB 设备连接器使用注意事项.....	7	操作上的注意事项.....	23
符号.....	8	USB 设备的充电方法.....	23
规格.....	8	维护和检查.....	24
标准附件.....	9	故障排除.....	26
选购附件（分开销售）.....	9	刀刃的选择.....	28
用途.....	10		

电动工具通用安全警告

警告！

阅读电动工具附带的所有安全警告、说明、插图和规格说明。
不遵照以下说明会导致电击、着火和 / 或严重伤害。

保存所有警告和说明书以备查阅。

在所有下列的警告中术语“电动工具”指市电驱动（有线）电动工具或电池驱动（无线）电动工具。

1) 工作场地的安全

- a) 保持工作场地清洁和明亮。
混乱和黑暗的场地会引发事故。
- b) 不要在易爆环境，如有易燃液体、气体或粉尘的环境下操作电动工具。
电动工具产生的火花会点燃粉尘或气体。
- c) 让儿童和旁观者离开后操作电动工具。
注意力不集中会使操作者失去对工具的控制。

2) 电气安全

- a) 电动工具插头必须与插座相配。绝不能以任何方式改装插头。需接地的电动工具不能使用任何转换插头。
未经改装的插头和相配的插座将减少电击危险。
- b) 避免人体接触接地表面，如管道、散热片和冰箱。
如果你身体接地会增加电击危险。
- c) 不得将电动工具暴露在雨中或潮湿环境中。
水进入电动工具将增加电击危险。

- d) 不得滥用电线。绝不能用电线搬运、拉动电动工具或拔出其插头。使电线远离热源、油、锐边或运动部件。
受损或缠绕的软线会增加电击危险。
- e) 当在户外使用电动工具时，使用适合户外使用的外接软线。
适合户外使用的软线将减少电击危险。
- f) 如果在潮湿环境下操作电动工具是不可避免的，应使用剩余电流动作保护器（RCD）。
使用RCD可减小电击危险。

3) 人身安全

- a) 保持警觉，当操作电动工具时关注所从事的操作并保持清醒。当你感到疲倦，或在有药物、酒精或治疗反应时，不要操作电动工具。
在操作电动工具时瞬间的疏忽会导致严重人身伤害。
- b) 使用个人防护装置。始终佩戴护目镜。
安全装置，诸如适当条件下使用防尘面具、防滑安全鞋、安全帽、听力防护等装置能减少人身伤害。
- c) 防止意外起动。确保开关在连接电源和 / 或电池盒、拿起或搬运工具时处于关断位置。
手指放在已接通电源的开关上或开关处于接通时插入插头可能会导致危险。
- d) 在电动工具接通之前，拿掉所有调节钥匙或扳手。
遗留在电动工具旋转零件上的扳手或钥匙会导致人身伤害。
- e) 手不要伸展得太长。时刻注意立足点和身体平衡。
这样在意外情况下能很好地控制电动工具。
- f) 着装适当。不要穿宽松衣服或佩戴饰品。让衣服、手套和头发远离运动部件。
宽松衣服、佩饰或长发可能会卷入运动部件中。
- g) 如果提供了与排屑、集尘设备连接用的装置，要确保它们连接完好且使用得当。
使用这些装置可减少尘屑引起的危险。
- h) 请勿因频繁使用工具的熟悉感而掉以轻心，忽视工具的安全性原则。
粗心的行为可能会导致瞬间发生严重伤害。

4) 电动工具使用和注意事项

- a) 不要滥用电动工具，根据用途使用适当的电动工具。
选用适当设计的电动工具会使你工作更有效、更安全。
- b) 如果开关不能接通或关断工具电源，则不能使用该电动工具。
不能用开关来控制的电动工具是危险的且必须进行修理。
- c) 在进行任何调整、更换附件或存放电动工具之前，必须从电源上拔掉插头和 / 或取下电池盒（如果可拆卸）。
这种防护性措施将减少工具意外起动的危险。

- d) 将闲置不用的电动工具贮存在儿童所及范围之外，并且不要让不熟悉电动工具或对这些说明不了解的人操作电动工具。
电动工具在未经培训的用户手中是危险的。
- e) 维护电动工具和附件。检查运动件是否调整到位或卡住，检查零件破损情况和影响电动工具运行的其他状况。如有损坏，电动工具应在使用前修理好。
许多事故由维护不良的电动工具引发。
- f) 保持切削刀具锋利和清洁。
保养良好的有锋利切削刃的刀具不易卡住而且容易控制。
- g) 按照使用说明书，考虑作业条件和进行的作业来使用电动工具、附件和工具的刀头等。
将电动工具用于那些与其用途不符的操作可能会导致危险。
- h) 保持手柄和抓握表面干燥、清洁，远离油和油脂。
如果手柄和抓握表面湿滑，可能导致在发生意外情况时，无法安全操作和控制工具。

5) 电池式工具使用和注意事项

- a) 只用制造商规定的充电器充电。
将适用于某种电池盒的充电器用到其他电池盒时会发生着火危险。
- b) 只使用配有特制电池盒的电动工具。
使用其他电池盒会发生损坏和着火危险。
- c) 当电池盒不用时，将它远离其他金属物体，例如回形针、硬币、钥匙、钉子、螺钉或其他小金属物体，以防一端与另一端连接。
电池端部短路会引起燃烧或火灾。
- d) 在滥用条件下，液体会从电池中溅出；避免接触。如果无意间碰到了，用水冲洗。如果液体碰到了眼睛，还要寻求医疗帮助。
从电池中溅出的液体会发生腐蚀或燃烧。
- e) 请勿使用损坏或改装的电池盒或工具。
损坏或改装的电池可能会引发突发状况，导致火灾、爆炸或受伤。
- f) 请勿将电池盒或工具暴露在有火源或高温环境中。
如果暴露在有火源或 130 度以上高温的环境中，可能引起爆炸。
- g) 请完全按照充电说明进行操作，不要在说明中规定的温度范围外的环境中对电池盒或工具充电。
充电不当或在规定温度范围外的环境中充电可能会导致电池损坏，增加发生火灾的风险。

6) 维修

- a) 将你的电动工具送交专业维修人员，使用同样的备件进行修理。
这样将确保所维修的电动工具的安全性。
- b) 请勿维修已损坏的电池盒。
需由制造商或经授权的服务供应商进行维修。

注意！

不可让儿童和体弱人士靠近工作场所。

应将不使用的工具存放在儿童和体弱人士接触不到的地方。

充电式往复锯使用注意事项

1. 务请在 $0^{\circ}\text{C} \sim 40^{\circ}\text{C}$ 的温度下进行充电。温度低于 0°C 将会导致充电过度，极其危险。电池不能在高于 40°C 的温度下充电。
最适合于充电的温度是 $20 \sim 25^{\circ}\text{C}$ 。
2. 不要连续使用充电器。
一次充电完毕后，在 15 分钟内不要再次使用该充电器对电池充电。
3. 勿让杂质进入充电式电池连结口内。
4. 切勿拆卸充电式电池与充电器。
5. 切勿使充电式电池短路。使电池短路将会造成很大的电流和过热，从而烧坏电池。
6. 请勿将电池丢入火中。
电池受热将会爆炸。
7. 在墙上、地板上或天花板上切割时，请检查埋入的电线等。
8. 充电后电池寿命太短不够使用时，请尽快将电池送往经销店。请勿将用过的电池乱丢。
9. 请勿使用耗竭了的电池，否则会损坏充电器。
10. 请勿将异物插入充电器的通风口。
若将金属异物或易燃物插入通风口的话，将会引起触电事故或使充电器受损。
11. 长时间连续使用本电钻，可能会导致机体过热，对马达及开关造成损害，因此使用本机请勿连续超过 15 分钟。
12. 为保护您的听力请在工作时带上耳塞。
13. 切勿在工作中或刚刚结束工作时触摸锯条，因为在工作中锯条会变得很热，触摸其将会造成严重的烫伤。
14. 请务必拿紧该电动工具的把手和前盖，否则产生的反作用力可能会导致不正确的或甚至危险的操作。
15. 在进行调整、更换附件或存放工具之前请取出电池或将开关置于锁定或关闭位置。
16. 请勿使用工具或电池端子（电池安装部位）明显变形的产品。
否则，安装电池后可能会短路，造成冒烟或起火。
17. 请清除工具端子（电池安装部位）上的削屑和灰尘。
 - 使用前请确保电池上没有堆积削屑和灰尘。
 - 在使用过程中，请尽量避免工具上的削屑或灰尘掉落在电池上。
 - 暂时不使用工具时或使用后，应将工具存放在不会掉落削屑或灰尘的地方。否则可能短路，造成冒烟或起火。

锂离子电池使用注意事项

为延长使用期限，锂离子电池备配停止输出的保护功能。

若是在使用本产品时发生下列 1 和 3 的情况，即使按下开关，马达也可能停止。这并非故障，而是启动保护功能的结果。

1. 在残留的电池电力即将耗尽时，马达会停止。
在这种情况下，请立即予以充电。
 2. 若工具超过负荷，马达亦可能停止。在这种情况下，请松开工具的开关，试着消除超过负荷的原因。之后您就可以再度使用。
 3. 若电池在过载工作情况下过热，电池电力可能会中止。
在这种情况下，请停止使用电池，让电池冷却。之后您就可以再度使用。
- 此外，请留心下列的警告及注意事项。

警告！

为防止发生电池漏电、发热、冒烟、爆炸及提前点燃，请确保留意下列事项。

1. 确保电池上没有堆积削屑及灰尘。
 - 在工作时确定削屑及灰尘没有掉落在电池上。
 - 确定所有工作时掉落在电动工具上的削屑和灰尘没有堆积在电池上。
 - 请勿将未使用的电池存放在曝露于削屑和灰尘的位置。
 - 在存放电池之前，请清除任何可能附着在上面的削屑和灰尘，并请切勿将它与金属零件（螺丝、钉子等）存放在一起。
2. 请勿以钉子等利器刺穿电池、以铁锤敲打、踩踏、丢掷电池，或将其剧烈撞击。
3. 切勿使用明显损坏或变形的电池。
4. 使用电池时请勿颠倒电极。
5. 请勿直接连接电源插座或汽车点烟器孔座。
6. 请依规定方式使用电池，切勿移作他用。
7. 如果已过了再充电时间，电池仍无法完成充电，请立即停止继续再充电。
8. 请勿将电池放置于高温或高压处，例如微波炉、烘干机或高压容器内。
9. 在发觉有渗漏或异味时，请勿接近远离火源。
10. 请勿在会产生强烈静电的地方使用。
11. 如有电池渗漏、异味、发热、褪色或变形，或在使用、充电或存放时出现任何异常，请立即将它从装备或电池充电器拆下，并停止使用。
12. 请勿浸泡电池或让任何液体流入电池内部。导电液体进入（如水），可能造成电池损坏，甚至可导致火灾或爆炸。将电池存放在阴凉、干燥的地方，远离易燃物品。必须避免将电池置于腐蚀性气体环境中。

注意！

1. 若电池渗漏出的液体进入您的眼睛，请勿搓揉眼睛，并以自来水等干净清水充分冲洗，立刻送医。
若不加以处理，液体可能会导致眼睛不适。
2. 若液体渗漏至您的皮肤或衣物，请立即以自来水等清水冲洗。
上述情况可能会使皮肤受到刺激。
3. 若初次使用电池时发现生锈、异味、过热、褪色、变形及 / 或其它异常情况时，请勿使用并将该电池退还给供货商或厂商。

警告！

如果有导电异物进入锂电池，可能发生短路，并有发生火灾危险的可能。请在贮存电池时，遵守如下事项。

- 请不要在电池盒内放置导电物体，如钉子、钢丝、铜丝或其他电线。
- 或者将电池装在电动工具中，或者在牢固按入电池盖并挡住通风孔后再存放，以防止短路（参照图 1）。



图 1

锂离子电池运输

当运输一个锂离子电池，请注意以下预防措施。

警告！

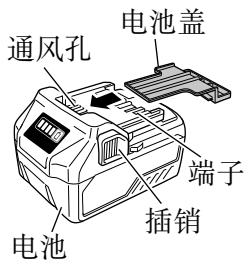
告知运输公司，包装内包含一个锂离子电池，告知该公司其功率输出并且要按照运输公司的指引安排运输。

- 功率输出超过 100 Wh 的锂离子电池被视作危险物品运输分类并且需要特别申请程序。
- 对于境外运输，您必须遵守国际法以及输入国的规章和条例。



图 2

USB设备连接器使用注意事项

发生意外情况时，本产品连接的 USB 中保存的数据可能发生损坏或丢失。使用本产品前，请务必备份 USB 设备中的数据。

请注意，如 USB 设备中存储的数据发生损坏、丢失或连接的设备发生损坏，本公司概不负责。

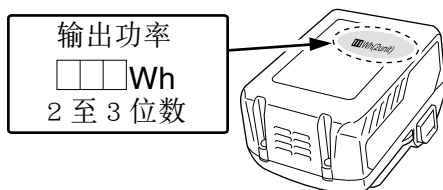
符号

警告！

如下所示的符号用于本机。使用前请务必理解其含意。

	为降低伤害风险，用户必须阅读使用说明书	n_0	空载转速
	直流电	/min	每分钟的振动次数
V	额定电压		警告

规格

电动工具

型式	CR36DA
无负荷速度	0 – 3000 /min
行程	32 mm
能力	软钢管：外径 130 mm
	聚氯乙烯管：外径 130 mm
	木材：厚度 120 mm
	软钢板：厚度 19 mm
电池 *	BSL36A18：锂离子 36 V / 18 V (2.5 Ah / 5.0 Ah 10 节)
重量	4.5 kg (安装 BSL36A18)





* 本工具不适用以下电池 (BSL3660/3626/3620、BSL18xx 和 BSL14xx 系列)。

充电器

型式	UC18YSL3
充电电压	14.4 V – 18 V
重量	0.6 kg

标准附件

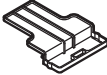
CR36DA 分为 2XC 型和 NN 型两种。各型号的附件请参见以下列表。

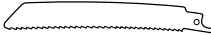
		CR36DA (2XC)	CR36DA (NN)
充电器 (UC18YSL3)		1	—
电池 (BSL36A18)		2	—
电池盖		1	—
塑料箱		1	—
刀刃 (141(S) 号)		1	1

选购附件 (分开销售)

1. 电池

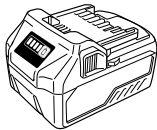

<BSL36A18>

2. 工具和转接器

- | | | |
|-------------|--------------|-----------------|
| (1) 4 号刀刃 | (7) 103 号刀刃 | (13) 121 号刀刃 |
| (2) 5 号刀刃 | (8) 104 号刀刃 | (14) 131 号刀刃 |
| (3) 95 号刀刃 | (9) 107 号刀刃 | (15) 132 号刀刃 |
| (4) 96 号刀刃 | (10) 108 号刀刃 | (16) 141(S) 号刀刃 |
| (5) 101 号刀刃 | (11) 109 号刀刃 | (17) 142(S) 号刀刃 |
| (6) 102 号刀刃 | (12) 110 号刀刃 | (18) 143(S) 号刀刃 |

○ (1) - (4) HCS 刀刃 (HCS: 高速碳钢)

○ (5) - (18) BI-METAL 刀刃

使用刀刃时, 请参照第 28-29 页的表 7, 表 8 和表 9。

用途

- 金属和不锈钢管的切锯。
 - 各种木材的切锯。
 - 软钢、铝和铜板的切锯。
 - 苯酚树脂、聚氯乙烯等合成树脂的切锯。
- 详细内容，请参照第 28 页的“刀刃的选择”一节的内容。

电池的拆卸 / 安装法

1. 电池的拆卸法

请先紧抓住把手，然后再推压电池插销以拆下电池（参照图 3 和图 4）。

注意！

切勿使电池短路。

2. 电池的安装法

插入电池时请注意极性（参照图 4）



图 3



图 4

充电

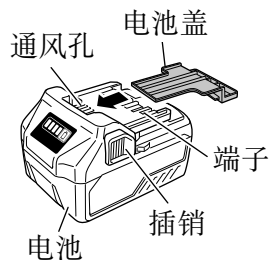
使用电动工具之前，按下述方法将电池进行充电。

1. 将充电器的电源线连接到插座。

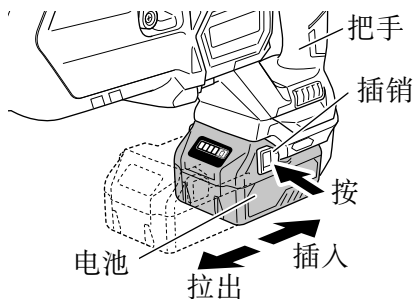
将充电器插头连接到插座时，指示灯闪烁红色（间隔为 1 秒）。

2. 将电池插入充电器。

如图 5 所示，将电池紧紧地插入充电器。



图 5

3. 充电





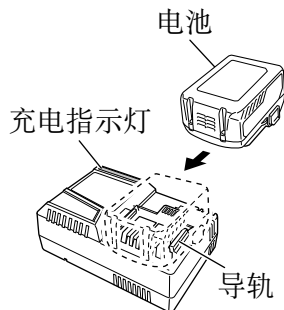

将电池插入充电器后，充电指示灯将呈蓝色闪烁。

电池完全充电后，充电指示灯将持续点亮呈绿色。（参照表 1）

(1) 充电指示灯的指示状态

根据充电器或可充电电池的情况，充电指示灯的显示如表 1 所示。

表 1

充电指示灯的指示状态				
充电指示灯 (红 / 蓝 / 绿 / 紫)	充电前	闪烁 (红)	点亮 0.5 秒钟。不点亮 0.5 秒钟。(熄灭 0.5 秒钟) 	插入电源
	充电时	闪烁 (蓝)	点亮 0.5 秒钟。不点亮 1 秒 钟。(熄灭 1 秒钟) 	电池电量低于 50%
		闪烁 (蓝)	点亮 1 秒钟。不点亮 0.5 秒钟。(熄灭 0.5 秒钟) 	电池电量低于 80%
		点亮 (蓝)	连续点亮 	电池电量高于 80%
	充电完成	点亮 (绿)	连续点亮  (发出持续蜂鸣声：约 6 秒)	
	过热 待机	闪烁 (红)	点亮 0.3 秒钟。不点亮 0.3 秒钟。(熄灭 0.3 秒钟) 	电池过热。无法充 电（电池冷却后将 开始充电）
	无法 充电	闪动 (紫色)	点亮 0.1 秒钟。不点亮 0.1 秒钟。(熄灭 0.1 秒钟)  (发出断续蜂鸣声：约 2 秒)	电池或充电器故障

中文

(2) 可充电电池温度和充电时间相关资料。
温度和充电时间如表 2 所示

表 2

充电器		UC18YSL3					
电池	电池类型	锂离子电池					
	电池可充电温度	-10°C - 50°C					
	充电电压	V	14.4		18		
	充电时间 (环境温度 20°C)	分钟	BSL14xx 系列		BSL18xx 系列		多电压系列
			(4 节)	(8 节)	(5 节)	(10 节)	(10 节)
			BSL1415S : 15 BSL1415 : 15 BSL1415X : 15 BSL1420 : 20 BSL1425 : 25 BSL1430C : 30	BSL1430 : 20 BSL1440 : 26 BSL1450 : 32 BSL1460 : 38	BSL1815S : 15 BSL1815 : 15 BSL1815X : 15 BSL1820 : 20 BSL1825 : 25 BSL1830C : 30	BSL1830 : 20 BSL1840 : 26 BSL1850 : 32 BSL1860 : 38	BSL36A18 : 32
USB	充电电压	V	5				
	充电电流	A	2				

注：

充电时间可能会因环境温度和电源电压而异。

4. 从电源插座拔下充电器的电源线。

5. 握紧充电器并取出电池。

注：

充电后，先将电池从充电器中取出，然后妥善保存。

关于新电池的放电。

新电池内部的化学物质未被激活或电池长时间不使用时，初次或第二次使用时需要将其放电至较低电量。这只是暂时现象，将电池充电 2-3 次即可恢复为充电所需的正常时间。

较长时间保持电池性能的方法

(1) 在电池电力完全耗尽之前进行充电。

感到电动工具的能力变弱时，请停止使用并给电池充电。若您继续使用电动工具并耗尽电力，电池可能会损坏或其使用寿命缩短。

(2) 避免在高温环境中充电。

使用后可充电电池的温度将迅速升高。若使用后立即对这种电池进行充电，其内部化学物质会劣化，电池使用寿命将缩短。请稍等片刻，待电池冷却后再进行充电。

注意！

- 如果电池长时间放置在阳光直射的地方或者刚刚使用完毕时，电池会变热。如果此时对电池充电，充电器的充电指示灯会点亮 0.3 秒钟，然后熄灭 0.3 秒钟（熄灭 0.3 秒钟）。此时请等待电池冷却后再开始充电。
- 充电指示灯闪动（闪动间隔为 0.2 秒钟）时，请检查充电器的电池连接器内是否有异物并加以清除。如没有异物，则可能是电池或充电器发生了故障。请将其送往当地授权服务中心。
- 因内置的微电脑需要约 3 秒钟才能确认正用 UC18YSL3 充电的电池已被取出，因此请等待 3 秒钟后再重新插入电池继续充电。如果在不到 3 秒内就插入电池，则电池可能充电不正常。

作业之前**注意！**

为避免发生严重事故，请确保开关处于关断位置，并取出电池。

1. 检查工作区域环境。
检查工作区域，确保没有杂物且不杂乱。
请勿使无关人员靠近。确保照明和通风充足。
2. 安装锯条
该工具采用了不使用扳钳或其他工具便可装卸锯条的可装卸式装置。
 - (1) 扭转控制杆，打开刀刃钳。
 - (2) 扭转控制杆，将刀刃座完全插入堵塞端部的插槽中。可朝上或朝下安装此刀刃。
(图 6、图 7)



图 6



图 7

中文

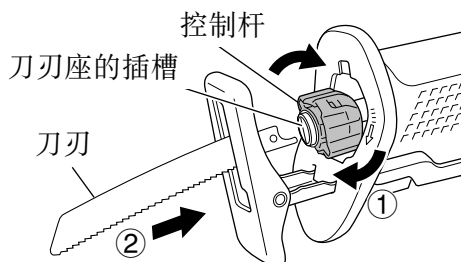
- (3) 松开控制杆时，弹簧的弹力会使控制杆自动返回正确的位置。
- (4) 用手试着拉刀刃背两三次，以确认刀刃已安装牢固。(图 8)

注意！

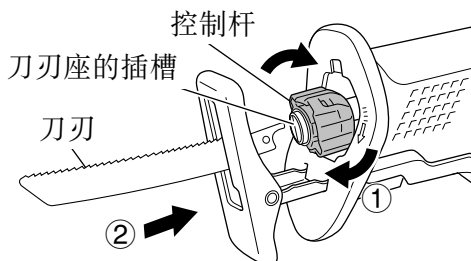
当拉动锯条时务必从后侧拉动，拉动锯条的其他部分将造成人身伤害。



图 8

3. 卸下锯条

注意！

切勿用手触摸刚刚使用过的锯条，否则，灼热的金属极易烫伤您的皮肤。

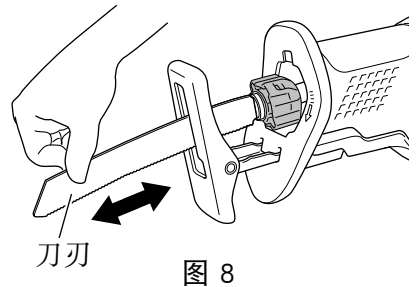
- (1) 转动控制杆后，将刀刃向下。刀刃会自行脱落。如果刀刃未掉下来，用手将刀刃拔出。

当刀刃损坏时

即使当刀刃破损并残留在刀刃座的小插槽内时，若扭转控制杆并使刀刃朝下，它仍会自行掉下。若未自行掉下，请按下述步骤将它取出。

- (1) 若损坏的刀刃某部分粘在了刀刃座的小插槽中，拔出插条并将刀刃拔出。
- (2) 若损坏的锯条藏在小插槽内部，请用锯条的尖部将其钩住并取出。(图 9)



图 9

电锯的维护和检查

- (1) 使用后，请用气刷或刷子清除掉锯条上的灰尘、泥土、尘沙或潮气等，以确保锯条的工作顺畅。

注：

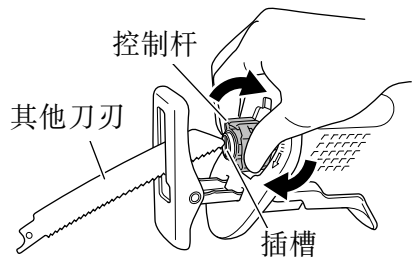
若在不干净或未润滑刀刃的状态下使用工具，控制杆的功能可能因积尘和碎屑而使控制杆运转不畅。此时可以扭转控制杆，并将刀刃座周围擦拭干净，吹走积尘。

注意！

请勿使用带有磨损刀刃孔的刀刃。否则，刀刃可能会掉下，导致人员受伤。(图 10)



图 10

4. 调结基座

为最大限度地延长刀刃的使用寿命，请滑入或滑出基座，调整行程长度以便于高效使用。

- (1) 断开开关，拆下电池。
- (2) 顺时针扭转基座控制杆；使基座滑至适宜位置。可将基座调至 5 个位置。
- (3) 逆时针扭转控制杆以固定基座。（图 11）
- (4) 请确保基座不会对刀刃产生干扰。

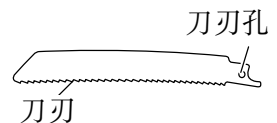

图 11

警告！

为了避免人员受伤和机器损坏，请勿在未安装基座的情况下操作本往复锯。否则可能会因刀刃座撞击工件而造成往复运动机构损坏。

5. 检查电池的插入

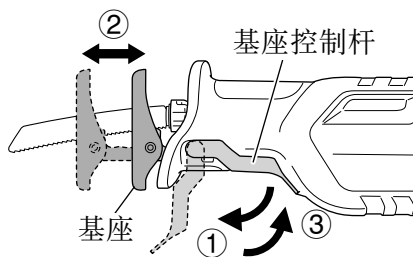
警告！

若电源开关接通，则插入电池后，电动工具将出其不意地立刻转动，从而导致严重事故。

注意！

请确保电池装入正确的位置，直至发出喀嗒声，否则可能会使电池突然掉落，导致使用者或周围人员受伤。

使用方法**警告！**

请勿触碰移动的部件。

注意！

- 在作业中请小心勿使锯屑、灰尘、水等通过柱塞部份进入机内。若锯屑等积于柱塞部份，请务必在使用前加以清除。
- 请勿取下前盖。
务必从前盖的顶部拿住机身。（图 12）
- 在使用时，在切锯作业中请将底座压在材料上面。
若未将底座紧紧压在工件上，振动会导致刀刃损坏。因此，有时刀刃端会接触管内壁，导致刀刃损坏。



图 12

中文

- 请选择长度最适当的刀刃。理论上，减去行程量后从刀刃座突出的刀刃长度应大于材料。（参照图 13 和图 15）

若切锯超过刀刃切锯能力的大工件、大木块等，刀刃可能会接触到管内壁和木料等，从而发生危险。（参照图 14 和图 16）。

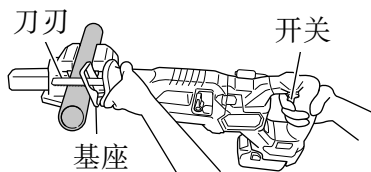
- 为延长使用期限，锂离子电池配备停止输出的保护功能。因此，若工具超过负荷，马达亦可能停止。然而，这并非故障问题，而是保护功能作用的结果。在这种情况下，请松开工具的开关，试着消除超过负荷的原因。

- 移动刀刃进行切锯时，请勿将工具从工件上移开。

- 完成作业后，取出电池。

注：

请勿锁住马达。若马达锁住，请立即断开开关。若马达已被锁住一段时间，可能会使马达或电池烧损。



图 13



图 14

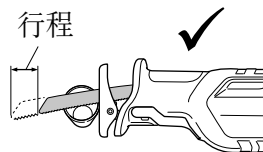

图 15

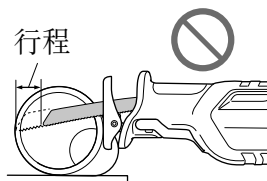

图 16

1. 开关的操作

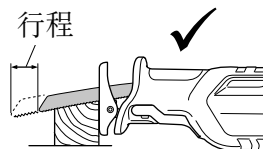
(1) 锁定解除按钮

本工具配有锁定解除按钮。若要启动工具，按下锁定解除按钮，然后按下扳机开关。（图 17）

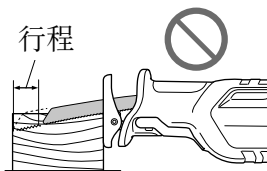
注意！

请勿固定锁定解除按钮。

此外，携带工具时，使手指远离扳机开关。否则可能会在不经意间按下扳机开关，导致意外事故。



图 17

(2) 搬钮开关

本工具配有控制各种速度的搬钮开关。通过按压和松开搬钮可将工具打开或关闭，通过按压搬钮来调整至合适的电锯的速度（从铭牌标注的最小速度至最大速度），向下按时速度加大，松开时速度减小。（图 18）

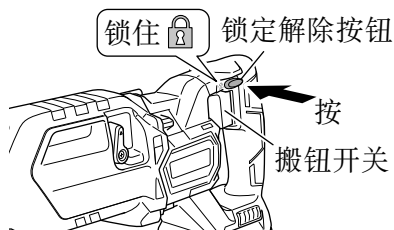

图 18

2. 调整运行速度

注意！

- 请勿撞击或损坏开关面板。
- 请在松开扳机开关时选择模式。否则可能导致故障。

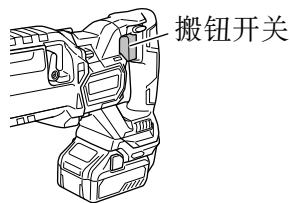
可根据机体开关的插入程度，将刀刃的行程量调节至任意级别。

此外，可利用模式选择开关选择行程量最大值。开关拉动的程度越大，则行程量越大。切锯作业启动时，开始将以低行程量（低速）准确切锯所需位置。实现准确切锯后，可增加行程量（高速），直至完成切锯。



图 19

安装电池并接通电源后，可通过按压模式选择开关更改模式。（图 20）

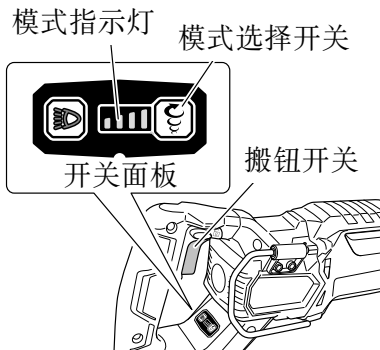

图 20

- 速度变化模式可切换以下 4 档的最大行程量：低速、中速、高速和最高速。
- 指示灯的状态和速度如第 18 页的表 3 所示。

表 3

模式		指示灯状态	运转速度	用途
传输模式	低速		0 – 1700 /min	不锈钢 塑料 纤维板
	中速		0 – 2000 /min	软钢板 铸铁管 L-型角钢 铝 / 黄铜 / 铜
	高速		0 – 2500 /min	石膏板 木材
	最高速		0 – 3000 /min	

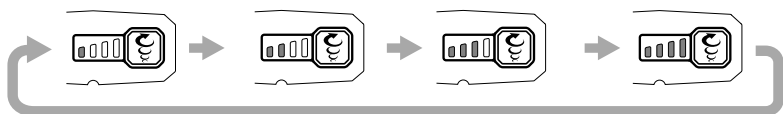
注：

仅在工具已安装电池且已拉动过一次扳机开关后，才可以对模式选择开关进行设定。

3. 行程量模式



该电动工具具备刀刃前后移动的直线模式，以及刀刃上下前后移动的轨道模式。

对于木材等软材料，应用轨道模式可实现平滑的锯割操作，还可改善锯末排放以及与材料的连锁。

使用选择杆选择最适合当前任务的模式。（图 21 和图 22）

根据锯割材料的硬度以及所需的完成度选择最合适的模式。参照表 4 进行选择。

表 4

行程量模式	直线模式		轨道模式
动作轨迹	前后		前后 + 上下
材料硬度	硬材料		软材料
锯割速度	慢		快
完成度	光滑		粗糙

注

○ 如要对软材料进行整齐锯割，请选择直线模式。

○ 如果选择杆上堆积了灰尘或尘土，可能会导致其无法顺畅移动，因此请偶尔进行清洁。

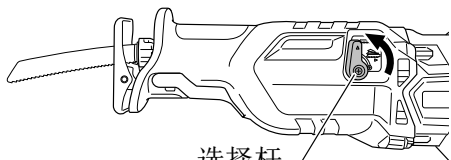

选择杆
(直线模式)

图 21

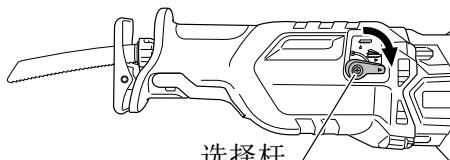

选择杆
(轨道模式)

图 22

4. 挂钩的使用方法

使用挂钩可以在运转期间暂时悬挂机体（图 23、图 24）。

注意！

请勿用挂钩悬挂人。

使用挂钩时，请确保主要机体不会滑倒或倒落，或被风吹动等。

请勿将机器挂在腰带或裤子上，否则可能会导致事故。

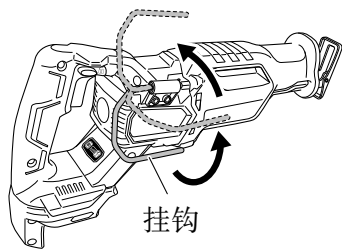

挂钩
图 23



图 24

5. 切锯金属材料

注意！

- 将底座紧紧按在工件之上。
- 切锯时请勿给刀刃施加异常力量。否则很容易损坏刀刃。
- 根据切割物的构成或锯条的不同有时马达会锁住。一旦马达锁住，请立即关闭开关。
- 不要在易爆环境，如有易燃液体、气体或粉尘的环境下操作电动工具。往复锯产生的火花会点燃粉尘或气体。

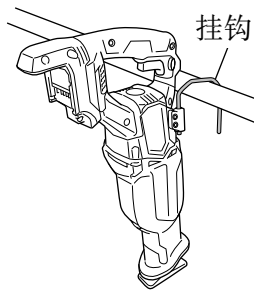
(1) 在作业前牢牢固定工件。（图 25）

(2) 在切锯金属材料时，请使用适当的机油（蜗轮油等）。未使用液体机油时，请给工件涂上润滑油。



图 25

注意！

若未使用机油，刀刃的使用寿命会大幅缩短。

6. 切锯木料

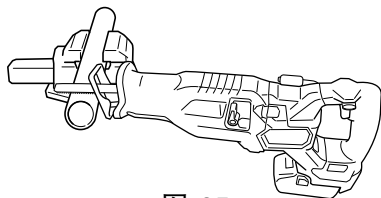
切锯木料时，在开始操作前务必先牢牢固定工件。（图 26）

注意！

切锯时请勿给刀刃施加异常力量。同时，请将底座紧紧压在木料上。



图 26

7. 切锯曲线

建议使用第 29 页表 8 中的 BI-METAL 刀刃，因为这种刀刃坚韧耐用。

注意！

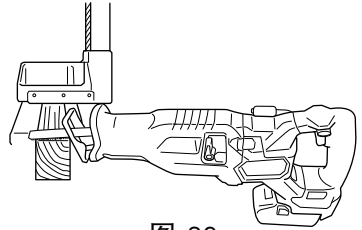
将材料切割成小圆弧时须降低进料速度，速度过快可能会损坏刀刃。

8. 插入切锯

使用本电动往复锯，可在木合板和薄板材料上进行插入切锯。使用本电动往复锯，可在木合板和薄板材料上插入切锯。如图 30、图 31、图 32 所示。请尽量使用短而薄的刀刃。为此，建议使用第 29 页表 8 中列出的 BI-METAL 刀刃号码 132 号。在切锯作业中请务必小心操作并遵守以下步骤。

- (1) 请将底座的下部（或上部）压在切锯材料上，使刀刃前端脱离切锯材料并扣扳机。（图 27、图 30）
- (2) 慢慢抬起把手并用刀刃一点一点地切入。（图 28、图 31）
- (3) 紧紧抓住机身，直至刀刃完全切入材料。（图 29、图 32）



图 27



图 28

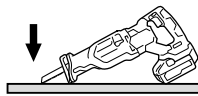

图 29

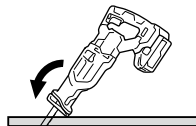

图 30

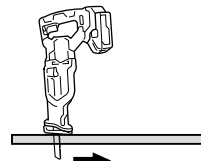

图 31



图 32

注意！

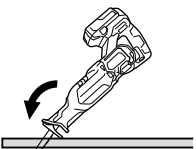
- 避免对金属材料进行切锯，否则很容易损坏刀刃。
- 在刀刃前端压在切锯材料上时切勿扣扳机。否则，当刀刃接触材料时很容易被损坏。
- 务必紧紧抓住机身缓慢地进行切锯。在切锯作业中若对刀刃异常用力，则很容易损坏刀刃。

9. LED 灯使用方法

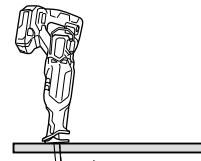
[正常使用]

当开关被拔出时，LED 灯将照亮工具的尖部区域。

松开开关约 10 秒后，LED 灯将自动熄灭。

[仅使用 LED 灯照明时（手提灯模式）]

按下开关面板上的照明开关就可以打开 / 关闭 LED 灯，而不必扣动扳机。

为了防止电池消耗，尽可能多地关闭 LED 灯。



图 33

注：

- 在 LED 打开的情况下，如果 1 小时左右未碰触开关，则将自动断电以防电量消耗。
- 扳动开关时，LED 灯将切换到 [正常使用] 模式。

注意！

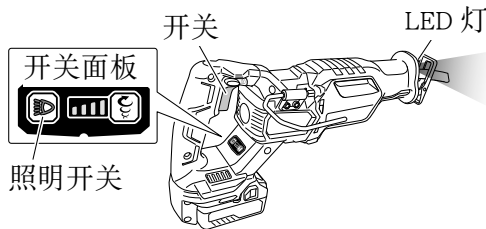
- 请不要直视灯光，避免眼睛直接受灯光照射。如果眼睛持续受灯光照射，会伤害眼睛。
- 用软布仔细擦拭附着在 LED 灯镜片上的灰尘或污垢，小心不要划伤镜片。如果划伤 LED 灯的镜片，可能会导致亮度减弱。

10. LED 灯警示信号（图 34）

该产品设计出具有保护该工具以及电池的功能。当拔出开关，如果在操作过程中任何保护功能启动，LED 灯将会如表 5 所描述的将进行闪光。当启动任何保护功能，立即将您的手指从开关上移开并按照正确步骤所描述的指引进行操作。



图 34

表 5

保护功能	LED 灯显示	正确步骤
负重过度保护	开启 0.1 秒 / 关闭 0.1 秒 ■ ■ ■ ■ ■ ■ ■ ■ ■ ■ ■ ■ ■ ■ ■ ■ ■ ■	解除负担过重原因。
温度保护	开启 0.5 秒 / 关闭 0.5 秒 ■■■■ ■■■■ ■■■■ ■■■■	让该工具和电池得到充分冷却。

11. 剩余电池电量指示灯

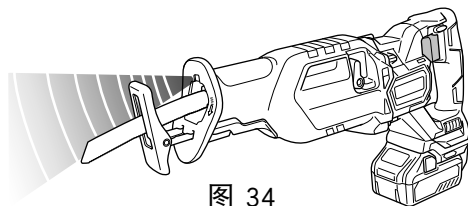
可以按下剩余电池电量指示灯开关点亮指示灯，查看电池的剩余电量。(图 35, 表 6)

按住剩余电池电量指示灯开关约 3 秒后，指示灯将熄灭。

环境温度和电池状态可能会对剩余电池电量产生轻微的影响，因此，建议您仅将指示灯作为参考。

此外，电动工具或充电器上的剩余电池电量指示灯可能有所不同。

剩余电池电量指示灯 剩余电池电量指示灯开关



图 35

表 6

指示灯状态	电池剩余电量
	点亮； 电池剩余电量超过 75%
	点亮； 电池剩余电量为 50% - 75%
	点亮； 电池剩余电量为 25% - 50%
	点亮； 电池剩余电量不到 25%
	闪烁； 电池剩余电量即将耗尽。请尽快对电池进行充电。
	闪烁； 因高温暂停输出从电动工具中取下电池，让电池完全冷却。
	闪烁； 因失败或故障暂停输出。电池可能出现故障，请与经销商联系。

环境温度和电池特性不同，则所显示的电池剩余电量也会有些许不同，以上内容仅供参考。

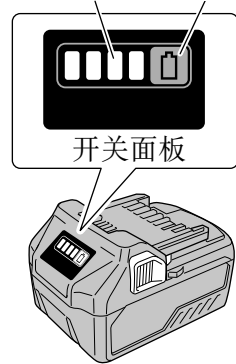
注：

请勿强烈撞击或破坏开关面板。否则可能会导致故障。

操作上的注意事项

连续作业后须让电动工具休息片刻

(1) 电动工具带有温度保护电路以保护马达。

长时间连续作业可能会导致机器温度升高、触发温度保护电路并自动停止作业。

如果发生这种情况，请让电动工具冷却后再使用。

(2) 请在长时间连续作业后或更换电池后，使机器静止 15 分钟。如果在更换电池后立刻开始作业，马达和开关等的温度将会升高，结果导致烧毁。

USB设备的充电方法

警告！

- 使用之前请检查 USB 连接线缆是否有破损或损坏。
使用有破损或损坏的 USB 线缆可能会导致冒烟或着火。
- 不使用产品时，请用橡胶盖封好 USB 端口。
USB 端口中落入灰尘等可能会导致冒烟或着火。

注：

- USB 充电过程中，可能会有偶尔暂停。
- USB 设备未充电时，请将充电器上拔下 USB 设备。
否则不仅会减少 USB 设备的电池寿命，还会导致意外事故。
- 根据设备类型，可能无法对部分 USB 设备进行充电。

(1) 选择充电方式

根据所选的充电方式，将电池插入充电器或连接电源线插入插座。

- 将 USB 设备插入插座进行充电（图 36-a）。
- 将 USB 设备和电池插入插座进行充电。（图 36-b）



图 36

中文

(2) 连接 USB 线缆。(图 37)

拔下橡胶盖并将市售的 USB 线缆（匹配充电的设备）紧紧插入 USB 端口。

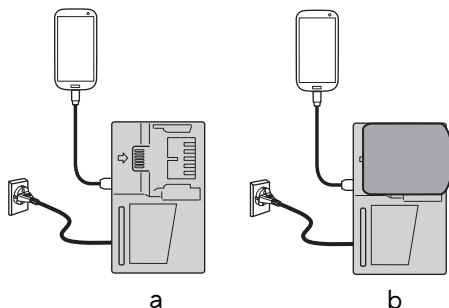

图 37

(3) 充电完成时

- 检查 USB 设备以检验充电状态。
- 从插座中拔下电源线。(图 38)
- 用橡胶盖盖住 USB 端口。

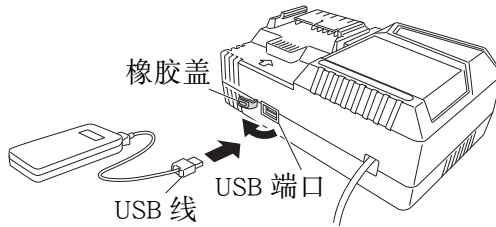

图 38

维护和检查

注意！

维护和检查前请务必关闭开关。

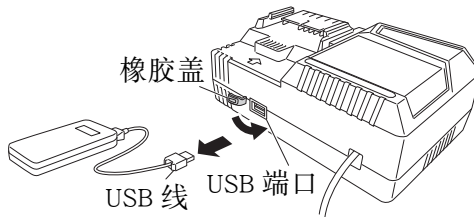
1. 检查刀刃

如继续使用已钝了的或已损坏了的刀刃，会降低工作效率并可能会引起马达超负荷。因此，一旦注意到刀刃磨损，请立即用新刀刃更换之。

注意！

若使用较钝的刀刃作业，则切锯时产生的反作用力会增加。请避免使用未经维修的较钝刀刃。

2. 检查安装螺钉

要经常检查安装螺钉是否紧固妥善。若发现螺钉松了，应立即重新扭紧，否则会导致严重的事故。

3. 电动机的维护

电动机绕线是电动工具的“心脏部”应仔细检查有无损伤，是否被油液或水沾湿。

4. 检查端子（工具和电池）

确保端子上没有堆积削屑和灰尘。

在操作前、操作时和操作后需要时常检查。

注意！

请清除端子上的削屑或灰尘。

否则可能导致故障。

5. 清理外部

电动工具沾污时，用干软布或沾肥皂水的布擦拭。切勿使用氯溶液、汽油或稀释剂，以免塑胶部分溶化。

6. 润滑

考虑到该工具在正常作业条件下的预期使用寿命，轴承已经过优质润滑油的充分润滑。因此，无需进一步润滑。

7. 收藏

电动工具应收藏于温度低于 40°C 和小孩拿不到的地方。

注：

存放锂离子电池

在存放前请确保电池已完全充电。

电池在低电量的状态下长时间存放（3 个月或更长），可能会导致电池性能劣化，使用时间明显减少或无法进行充电。

但是，即使是使用时间明显减少的电池，通过反复充电和使用 2 ~ 5 次，有时也可恢复使用时间。

若反复充电和使用后电池的使用时间仍非常短，请认作为电池已达到了使用寿命并更换新的电池。

注意！

在操作和维修电动工具时，必须遵守贵国制定的安全的有关规则和标准。

关于 HiKOKI 牌无线电动工具的重要通知：

请确保始终使用我们指定的正版电池。如果使用我们指定以外的电池，或对电池进行拆卸和改动（例如拆卸和更换电池组件或其他内部部件），那么我们无法保证我们无线电动工具的安全性和使用性能。

故障排除

如果工具操作不正常，请使用下表中的检查步骤。如果未能解决问题，请向经销商或 HIKOKI 公司授权服务中心咨询。

1. 电动工具

现象	可能的原因	解决办法
工具无法运行	没有剩余电池电量	为电池充电
工具突然停止	工具过度负重	避免因负载过重而引发的问题。 在操作过程中减轻施力。
	电池或工具过热	让工具和电池完全冷却。
	按下扳机开关 5 分钟或更久。	这种情况不属于故障。 电机已自动停止以防止工具发生故障。
锯片 - 无法安装 - 掉落	安装部分的形状不匹配	选用合适的刀片 (请参见第 9 页的“选购附件”)
	刀刃的安装孔磨损	更换新的刀刃。
无法拔出开关	已按下锁定解除按钮	松开锁定解除按钮。
拉动扳机开关时， 将发出异常尖锐 的噪声。	请轻微拉动扳机开关。	这种情况不属于故障。 如果充分拉动扳机开关，则不会 发生此种情况。
刀刃磨损过快。	行程量过快 模式错误	从当前模式切换至低设置的模式。 (切割不锈钢管时请切换至低速 模式) (请参见第 17 页的“调整运行速 度”)
	锯割金属材料时未正确使用 机械油	使用机械油（透平油等）
	操作时施力过度	在操作过程中减轻施力。
无法正确锯割。	刀刃不适用于锯割材料的 质量和厚度	选用正确的刀片 (请参见第 9 页的“选购附件”)
	刀刃过短，不适用于锯割 材料的长度	
	模式不适用于锯割材料的 质量和厚度	请参见适宜模式 (请参见第 17 页的“调整运行速 度”)
	刀刃磨损、退化或损坏	更换新的刀刃。

现象	可能的原因	解决办法
无法安装电池	请尝试安装该工具指定的其他正版电池。	请安装多电压式电池。

2. 充电器

现象	可能的原因	解决办法
充电指示灯快速闪动紫色，电池未开始充电。	电池未完全插入。	请紧紧插入电池。
	电池端部或电池的连接处有异物。	将异物清除。
充电指示灯闪烁红色，电池未开始充电。	电池未完全插入。	请紧紧插入电池。
	电池过热。	如果继续放置，电池将在温度降低后自动开始充电，但此种情况可能会缩短电池使用寿命。建议将电池放置在通风良好的位置，在充电前避免阳光直射。
即使电池完全充电，电池的使用寿命也会逐渐缩短。	电池的使用寿命已耗尽。	请更换新电池。
电池的充电时间较长。	电池、充电器或周围环境的温度过低。	请在室内或温暖的环境中充电。
	充电器的排气孔堵塞，导致其内部部件过热。	请勿堵塞排气孔。
	冷却扇未运转。	请联系 HiKOKI 授权服务中心进行维修。
USB 电源灯熄灭，USB 设备停止充电。	电池剩余电量低。	用电量充足电池替换它。
		将充电器的电源插头插入电插座中。
即使 USB 设备充电完毕，USB 电源灯也不熄灭。	USB 电源灯点亮呈绿色，提示可进行 USB 充电。	这种情况不属于故障。
不清楚 USB 设备的充电状态如何或者是否充电完毕。	即使充电完毕，USB 电源灯也不熄灭。	检查正在充电的 USB 设备以确定其充电状态。

现象	可能的原因	解决办法
USB 设备在中途暂停充电。	使用电池作为电源对 USB 设备进行充电时，充电器插入电插座。	这种情况不属于故障。 充电器与电源间存在差异时，USB 将暂停充电约 5 秒钟。
	使用电源插座作为电源对 USB 设备进行充电时，电池插入充电器。	
电池和 USB 设备同时充电时，USB 设备将在中途暂停充电。	电池已完全充电。	这种情况不属于故障。 检查电池是否已充电完成时，充电器将暂停 USB 充电约 5 秒钟。
电池和 USB 设备同时充电时，USB 设备将无法开始充电。	电池剩余电量已不足。	这种情况不属于故障。 电池电量达到一定程度时，USB 将自动开始充电。

刀刃的选择

为了确保最大工作效率和效果，必须选择种类和厚度最适合切锯材料的刀刃。
注：

表中所示的工件尺寸，表示将底座设置于最靠近充电式往复锯安装位置时的尺寸。须注意，若将底座安装在远离充电式往复锯处，则工件尺寸将变小。

1. HSC 刀刃的选择

表 7 中 HCS 刀刃的刀刃号码标示于各刀刃的安装位置附近。请参照下面表 7 和表 9 来选择适当的刀刃。

表 7: HCS 刀刃

刀刃号码	用途	厚度 (mm)
4 号	切锯和磨毛木料	50 - 70
5 号	切锯和磨毛木料	30 以下
95 号	切锯直径小于 100 mm 的不锈钢管	2.5 以下
96 号	切锯直径小于 30 mm 的不锈钢管	2.5 以下

注：

4 号 - 96 号 HSC 刀刃为另售件。

2. BI-METAL 刀刃的选择

表 8 中的 BI-METAL 刀刃号码表示特殊套装附件。请参照下面表 8 和表 9 选择适当的刀刃。

表 8: BI-METAL 刀刃

刀刃号码	用途	厚度 (mm)
101 号 103 号 109 号 141(S) 号	切锯外径小于 60 mm 的钢管和不锈钢管	2.5 - 6
102 号 104 号 110 号 142(S) 号 143(S) 号	切锯外径小于 100 mm 的钢管和不锈钢管	2.5 - 6
107 号	切锯外径小于 60 mm 的钢管和不锈钢管	3.5 以下
108 号	切锯外径小于 100 mm 的钢管和不锈钢管	3.5 以下
121 号	切锯和磨毛木料	100
131 号	多用途	100
132 号	多用途	100

注：

101 号至 132 号 BI-METAL 刀刃为另售件。

3. 选择用于其他材料的刀刃

表 9

切锯材料	材料性质	厚度 (mm)	刀刃号码
铁板	软钢板	2.5 - 10	101, 102, 103, 104, 109, 110, 131, 141(S), 142(S), 143(S) 号
		3.5 以下	107, 108 号
有色金属	铝、铜和黄铜	5 - 20	101, 102, 103, 104, 109, 110, 131, 132, 141(S), 142(S), 143(S) 号
		5 以下	107, 108 号
合成树脂	苯酚树脂、蜜胺 甲醛树脂等	10 - 50	101, 102, 103, 104, 131, 132, 141(S), 142(S), 143(S) 号
		5 - 30	107, 108, 109, 110 号
	聚氯乙烯树脂、 丙烯酸树脂等	10 - 60	101, 102, 103, 104, 131, 132, 141(S), 142(S), 143(S) 号
		5 - 30	107, 108, 109, 110 号

CONTENTS

GENERAL POWER TOOL SAFETY WARNINGS	30
PRECAUTIONS FOR CORDLESS RECIPROCATING SAW	33
CAUTION ON LITHIUM-ION BATTERY	34
REGARDING LITHIUM-ION BATTERY TRANSPORTATION	36
USB DEVICE CONNECTION PRECAUTIONS	36
SYMBOL.....	36
SPECIFICATIONS	37
STANDARD ACCESSORIES	37
OPTIONAL ACCESSORIES (sold separately).....	38
APPLICATIONS.....	38
BATTERY REMOVAL/INSTALLATION	38
CHARGING	39
PRIOR TO OPERATION.....	42
HOW TO USE.....	45
OPERATIONAL CAUTIONS.....	52
HOW TO RECHARGE USB DEVICE	52
MAINTENANCE AND INSPECTION	54
TROUBLESHOOTING.....	56
SELECTION OF BLADES	59

GENERAL POWER TOOL SAFETY WARNINGS

WARNING

Read all safety warnings, instructions, illustrations and specifications provided with this power tool.

Failure to follow all instructions listed below may result in electric shock, fire and/or serious injury.

Save all warnings and instructions for future reference.

The term “power tool” in the warnings refers to your mains-operated (corded) power tool or battery-operated (cordless) power tool.

- 1) **Work area safety**
 - a) **Keep work area clean and well lit.**
Cluttered or dark areas invite accidents.
 - b) **Do not operate power tools in explosive atmospheres, such as in the presence of flammable liquids, gases or dust.**
Power tools create sparks which may ignite the dust or fumes.
 - c) **Keep children and bystanders away while operating a power tool.**
Distractions can cause you to lose control.

- 2) **Electrical safety**
 - a) **Power tool plugs must match the outlet.**
Never modify the plug in any way.
Do not use any adapter plugs with earthed (grounded) power tools.

Unmodified plugs and matching outlets will reduce risk of electric shock.

- b) **Avoid body contact with earthed or grounded surfaces, such as pipes, radiators, ranges and refrigerators.**

There is an increased risk of electric shock if your body is earthed or grounded.

- c) **Do not expose power tools to rain or wet conditions.**

Water entering a power tool will increase the risk of electric shock.

- d) **Do not abuse the cord. Never use the cord for carrying, pulling or unplugging the power tool.**

Keep cord away from heat, oil, sharp edges or moving parts.

Damaged or entangled cords increase the risk of electric shock.

- e) **When operating a power tool outdoors, use an extension cord suitable for outdoor use.**

Use of a cord suitable for outdoor use reduces the risk of electric shock.

- f) **If operating a power tool in a damp location is unavoidable, use a residual current device (RCD) protected supply.**

Use of an RCD reduces the risk of electric shock.

3) Personal safety

- a) **Stay alert, watch what you are doing and use common sense when operating a power tool.**

Do not use a power tool while you are tired or under the influence of drugs, alcohol or medication.

A moment of inattention while operating power tools may result in serious personal injury.

- b) **Use personal protective equipment. Always wear eye protection.**

Protective equipment such as a dust mask, non-skid safety shoes, hard hat or hearing protection used for appropriate conditions will reduce personal injuries.

- c) **Prevent unintentional starting. Ensure the switch is in the off-position before connecting to power source and/or battery pack, picking up or carrying the tool.**

Carrying power tools with your finger on the switch or energising power tools that have the switch on invites accidents.

- d) **Remove any adjusting key or wrench before turning the power tool on.**

A wrench or a key left attached to a rotating part of the power tool may result in personal injury.

- e) **Do not overreach. Keep proper footing and balance at all times.**

This enables better control of the power tool in unexpected situations.

- f) **Dress properly. Do not wear loose clothing or jewellery. Keep your hair, clothing and gloves away from moving parts.**

Loose clothes, jewellery or long hair can be caught in moving parts.

- g) **If devices are provided for the connection of dust extraction and collection facilities, ensure these are connected and properly used.**

Use of dust collection can reduce dust-related hazards.

- h) **Do not let familiarity gained from frequent use of tools allow you to become complacent and ignore tool safety principles.**

A careless action can cause severe injury within a fraction of a second.

English

4) Power tool use and care

- a) **Do not force the power tool. Use the correct power tool for your application.**
The correct power tool will do the job better and safer at the rate for which it was designed.
- b) **Do not use the power tool if the switch does not turn it on and off.**
Any power tool that cannot be controlled with the switch is dangerous and must be repaired.
- c) **Disconnect the plug from the power source and/or remove the battery pack, if detachable, from the power tool before making any adjustments, changing accessories, or storing power tools.**
Such preventive safety measures reduce the risk of starting the power tool accidentally.
- d) **Store idle power tools out of the reach of children and do not allow persons unfamiliar with the power tool or these instructions to operate the power tool.**
Power tools are dangerous in the hands of untrained users.
- e) **Maintain power tools and accessories. Check for misalignment or binding of moving parts, breakage of parts and any other condition that may affect the power tool's operation.**
If damaged, have the power tool repaired before use.
Many accidents are caused by poorly maintained power tools.
- f) **Keep cutting tools sharp and clean.**
Properly maintained cutting tools with sharp cutting edges are less likely to bind and are easier to control.
- g) **Use the power tool, accessories and tool bits etc. in accordance with these instructions, taking into account the working conditions and the work to be performed.**
Use of the power tool for operations different from those intended could result in a hazardous situation.
- h) **Keep handles and grasping surfaces dry, clean and free from oil and grease.**
Slippery handles and grasping surfaces do not allow for safe handling and control of the tool in unexpected situations.

5) Battery tool use and care

- a) **Recharge only with the charger specified by the manufacturer.**
A charger that is suitable for one type of battery pack may create a risk of fire when used with another battery pack.
- b) **Use power tools only with specifically designated battery packs.**
Use of any other battery packs may create a risk of injury and fire.
- c) **When battery pack is not in use, keep it away from other metal objects, like paper clips, coins, keys, nails, screws or other small metal objects, that can make a connection from one terminal to another.**
Shorting the battery terminals together may cause burns or a fire.
- d) **Under abusive conditions, liquid may be ejected from the battery; avoid contact. If contact accidentally occurs, flush with water. If liquid contacts eyes, additionally seek medical help.**
Liquid ejected from the battery may cause irritation or burns.

- e) **Do not use a battery pack or tool that is damaged or modified.**
Damaged or modified batteries may exhibit unpredictable behaviour resulting in fire, explosion or risk of injury.
- f) **Do not expose a battery pack or tool to fire or excessive temperature.**
Exposure to fire or temperature above 130 °C may cause explosion.
- g) **Follow all charging instructions and do not charge the battery pack or tool outside the temperature range specified in the instructions.**
Charging improperly or at temperatures outside the specified range may damage the battery and increase the risk of fire.
- 6) **Service**
- a) **Have your power tool serviced by a qualified repair person using only identical replacement parts.**
This will ensure that the safety of the power tool is maintained.
- b) **Never service damaged battery packs.**
Service of battery packs should only be performed by the manufacturer or authorized service providers.

CAUTION

Keep children and infirm persons away.

When not in use, tools should be stored out of reach of children and infirm persons.

PRECAUTIONS FOR CORDLESS RECIPROCATING SAW

1. **Always charge the battery at a temperature of 0 – 40°C.**
A temperature of less than 0°C will result in over charging which is dangerous. The battery cannot be charged at a temperature higher than 40°C.
The most suitable temperature for charging is that of 20 – 25°C.
2. **Do not use the charger continuously.**
When one charging is completed, leave the charger for about 15 minutes before the next charging of battery.
3. **Do not allow foreign matter to enter the hole for connecting the rechargeable battery.**
4. **Never disassemble the rechargeable battery and charger.**
5. **Never short-circuit the rechargeable battery.** Short-circuiting the battery will cause a great electric current and overheat. It results in burn or damage to the battery.
6. **Do not dispose of the battery in fire.**
If the battery is burnt, it may explode.
7. **When cutting in wall, floor or ceiling, check for buried electric power cord, etc.**
8. **Bring the battery to the shop from which it was purchased as soon as the post-charging battery life becomes too short for practical use.** Do not dispose of the exhausted battery.
9. **Using an exhausted battery will damage the charger.**
10. **Do not insert object into the air ventilation slots of the charger.**
Inserting metal objects or inflammables into the charger air ventilation slots will result in electrical shock hazard or damaged charger.

English

11. When using this unit continuously, the unit may overheat, leading to damage in the motor and switch. Please leave it without using it for approximately 15 minutes.
12. Wear earplugs to protect your ears during operation.
13. Do not touch the blade during or immediately after operation. The blade becomes very hot during operation and could cause serious burns.
14. Always hold the body handle and front cover of the power tool firmly. Otherwise the counterforce produced may result in inaccurate and even dangerous operation.
15. Remove the battery from tool or place the switch in the locked or off position before making any adjustments, changing accessories, or storing the tools.
16. Do not use the product if the tool or the battery terminals (battery mount) are deformed.

Installing the battery could cause a short circuit that could result in smoke emission or ignition.

17. Keep the tool's terminals (battery mount) free of swarf and dust.
 - Prior to use, make sure that swarf and dust have not collected in the area of the terminals.
 - During use, try to avoid swarf or dust on the tool from falling on the battery.
 - When suspending operation or after use, do not leave the tool in an area where it may be exposed to falling swarf or dust.Doing so could cause a short circuit that could result in smoke emission or ignition.

CAUTION ON LITHIUM-ION BATTERY

To extend the lifetime, the lithium-ion battery equips with the protection function to stop the output.

In the cases of 1 to 3 described below, when using this product, even if you are pulling the switch, the motor may stop. This is not the trouble but the result of protection function.

1. When the battery power remaining runs out, the motor stops.
In such case, charge it up immediately.
2. If the tool is overloaded, the motor may stop. In this case, release the switch of tool and eliminate causes of overloading. After that, you can use it again.
3. If the battery is overheated under overload work, the battery power may stop.
In this case, stop using the battery and let the battery cool. After that, you can use it again.

Furthermore, please heed the following warning and caution.

WARNING

In order to prevent any battery leakage, heat generation, smoke emission, explosion and ignition beforehand, please be sure to heed the following precautions.

1. Make sure that swarf and dust do not collect on the battery.
 - During work make sure that swarf and dust do not fall on the battery.
 - Make sure that any swarf and dust falling on the power tool during work do not collect on the battery.
 - Do not store an unused battery in a location exposed to swarf and dust.

- Before storing a battery, remove any swarf and dust that may adhere to it and do not store it together with metal parts (screws, nails, etc.).
- 2. Do not pierce battery with a sharp object such as a nail, strike with a hammer, step on, throw or subject the battery to severe physical shock.
- 3. Do not use an apparently damaged or deformed battery.
- 4. Do not use the battery in reverse polarity.
- 5. Do not connect directly to an electrical outlets or car cigarette lighter sockets.
- 6. Do not use the battery for a purpose other than those specified.
- 7. If the battery charging fails to complete even when a specified recharging time has elapsed, immediately stop further recharging.
- 8. Do not put or subject the battery to high temperatures or high pressure such as into a microwave oven, dryer, or high pressure container.
- 9. Keep away from fire immediately when leakage or foul odor are detected.
- 10. Do not use in a location where strong static electricity generates.
- 11. If there is battery leakage, foul odor, heat generated, discolored or deformed, or in any way appears abnormal during use, recharging or storage, immediately remove it from the equipment or battery charger, and stop use.
- 12. Do not immerse the battery or allow any fluids to flow inside. Conductive liquid ingress, such as water, can cause damage resulting in fire or explosion. Store your battery in a cool, dry place, away from combustible and flammable items. Corrosive gas atmospheres must be avoided.

CAUTION

- 1. If liquid leaking from the battery gets into your eyes, do not rub your eyes and wash them well with fresh clean water such as tap water and contact a doctor immediately.
If left untreated, the liquid may cause eye-problems.
- 2. If liquid leaks onto your skin or clothes, wash well with clean water such as tap water immediately.
There is a possibility that this can cause skin irritation.
- 3. If you find rust, foul odor, overheating, discolor, deformation, and/or other irregularities when using the battery for the first time, do not use and return it to your supplier or vendor.

WARNING

If an electrically conductive foreign object enters the terminals of the lithium ion battery, a short-circuit may occur resulting in the risk of fire. Please observe the following matters when storing the battery.

- Do not place electrically conductive cuttings, nails, steel wire, copper wire or other wire in the storage case.
- Either install the battery in the power tool or store by securely pressing into the battery cover until the ventilation holes are concealed to prevent short-circuits (See Fig. 1).

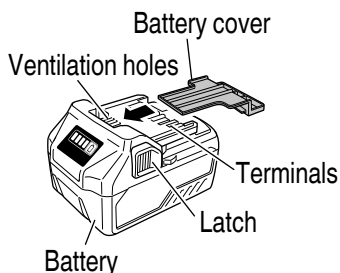

Fig. 1

REGARDING LITHIUM-ION BATTERY TRANSPORTATION

When transporting a lithium-ion battery, please observe the following precautions.

WARNING

Notify the transporting company that a package contains a lithium-ion battery, inform the company of its power output and follow the instructions of the transportation company when arranging transport.

- Lithium-ion batteries that exceed a power output of 100Wh are considered to be in the freight classification of Dangerous Goods and will require special application procedures.
- For transportation abroad, you must comply with international law and the rules and regulations of the destination country.

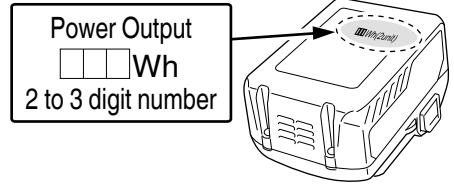

Fig. 2

USB DEVICE CONNECTION PRECAUTIONS



When an unexpected problem occurs, the data in a USB device connected to this product may be corrupted or lost. Always make sure to back up any data contained in the USB device prior to use with this product.

Please be aware that our company accepts absolutely no responsibility for any data stored in a USB device that is corrupted or lost, nor for any damage that may occur to a connected device.

SYMBOL

WARNING

The following show symbols used for the machine. Be sure that you understand their meaning before use.

	To reduce the risk of injury, user must read instruction manual.	n_0	No-load speed
	Direct current	/min	Oscillation per minute
V	Rated voltage		Warning

SPECIFICATIONS

Power Tool

Model	CR36DA
No-load speed	0 – 3000 /min
Stroke	32 mm
Capacity	Mild Steel Pipe: O.D. 130 mm
	Vinyl Chloride Pipe: O.D. 130 mm
	Wood: Depth 120 mm
	Mild Steel Plate: Thickness 19 mm
Battery*	BSL36A18: Li-ion 36 V / 18 V (2.5 Ah / 5.0 Ah 10 cells)
Weight	4.5 kg (BSL 36A18 attached)



* Existing batteries (BSL3660/3626/3620, BSL18xx and BSL14xx series) cannot be used with this tool.

Charger

Model	UC18YSL3
Charging voltage	14.4 – 18 V
Weight	0.6 kg

STANDARD ACCESSORIES

CR36DA have two types which are designated as 2XC and NN. For their respective accessories, see the Table below.

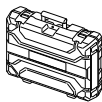
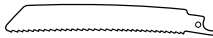
		CR36DA (2XC)	CR36DA (NN)
Charger (UC18YSL3)		1	—
Battery (BSL36A18)		2	—
Battery cover		1	—
Plastic case		1	—
Blade (No. 141(S))		1	1

OPTIONAL ACCESSORIES (sold separately)

1. Battery

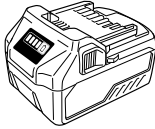

<BSL36A18>

2. Blades

- | | | |
|-------------------|--------------------|-----------------------|
| (1) No. 4 Blade | (7) No. 103 Blade | (13) No. 121 Blade |
| (2) No. 5 Blade | (8) No. 104 Blade | (14) No. 131 Blade |
| (3) No. 95 Blade | (9) No. 107 Blade | (15) No. 132 Blade |
| (4) No. 96 Blade | (10) No. 108 Blade | (16) No. 141(S) Blade |
| (5) No. 101 Blade | (11) No. 109 Blade | (17) No. 142(S) Blade |
| (6) No. 102 Blade | (12) No. 110 Blade | (18) No. 143(S) Blade |

○ (1) – (4): HCS Blades (HCS: Highspeed Carbon Steel)

○ (5) – (18): BI-METAL Blades.

Refer to **Table 7, 8 and 9 on page 59-60** for use of the blades.

APPLICATIONS

- Cutting metal and stainless steel pipe.
- Cutting various lumbers.
- Cutting mild steel, aluminum and copper plate.
- Cutting synthetic resins, such as phenol resin and vinyl chloride.

For details refer to the section entitled “SELECTION OF BLADES” on page 59.

BATTERY REMOVAL/INSTALLATION

1. Battery removal

Hold the handle tightly and push the battery latches to remove the battery (see **Fig. 3 and 4**).

CAUTION

Never short-circuit the battery.

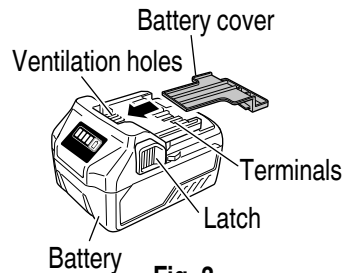

Fig. 3

- Battery installation
Insert the battery while observing its polarities
(See Fig. 4).

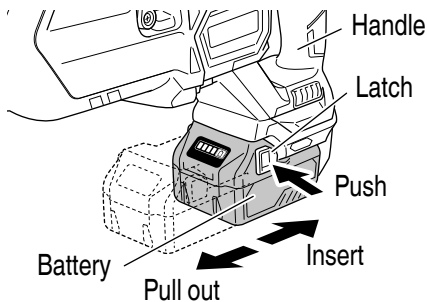

Fig. 4

CHARGING

Before using the power tool, charge the battery as follows.

- Connect the charger's power cord to the receptacle.**

When connecting the plug of the charger to a receptacle, the pilot lamp will blink in red (At 1- second intervals).

- Insert the battery into the charger.**

Firmly insert the battery into the charger as shown in Fig. 5.

- Charging**

When inserting a battery in the charger, the charge indicator lamp will blink in blue.

When the battery becomes fully recharged, the charge indicator lamp will light up in green. (See **Table 1 on page 40**)

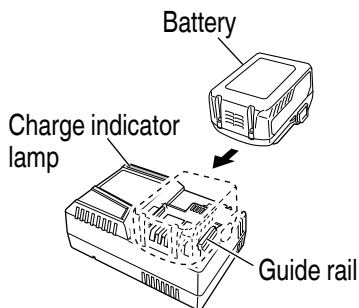









Fig. 5

English

(1) Charge indicator lamp indication

The indications of the charge indicator lamp will be as shown in **Table 1**, according to the condition of the charger or the rechargeable battery.

Table 1

Indications of the charge indicator lamp				
Charge indicator lamp (RED / BLUE / GREEN / PURPLE)	Before charging	Blinks (RED)	Lights for 0.5 seconds. Does not light for 0.5 seconds. (off for 0.5 seconds) 	Plugged into power source
	While charging	Blinks (BLUE)	Lights for 0.5 seconds. Does not light for 1 second. (off for 1 second) 	Battery capacity at less than 50%
		Blinks (BLUE)	Lights for 1 second. Does not light for 0.5 seconds. (off for 0.5 seconds) 	Battery capacity at less than 80%
		Lights (BLUE)	Lights continuously 	Battery capacity at more than 80%
	Charging complete	Lights (GREEN)	Lights continuously  (Continuous buzzer sound: about 6 seconds)	
	Overheat standby	Blinks (RED)	Lights for 0.3 seconds. Does not light for 0.3 seconds. (off for 0.3 seconds) 	Battery overheated. Unable to charge. (Charging will commence when battery cools)
	Charging impossible	Flickers (PURPLE)	Lights for 0.1 seconds. Does not light for 0.1 seconds. (off for 0.1 seconds)  (Intermittent buzzer sound: about 2 seconds)	Malfunction in the battery or the charger

- (2) Regarding the temperatures and charging time of the rechargeable battery
The temperatures and charging time will become as shown in **Table 2**.

Table 2

Charger		UC18YSL3					
Battery	Type of battery	Li-ion					
	Temperatures at which the battery can be recharged	-10 °C – 50 °C					
	Charging voltage	V	14.4		18		
	Charging time, approx. (At 20°C)	min.	BSL14xx series		BSL18xx series		Multi volt series
			(4 cells)	(8 cells)	(5 cells)	(10 cells)	(10 cells)
		BSL1415S : 15 BSL1415 : 15 BSL1415X : 15 BSL1420 : 20 BSL1425 : 25 BSL1430C : 30	BSL1430 : 20 BSL1440 : 26 BSL1450 : 32 BSL1460 : 38	BSL1815S : 15 BSL1815 : 15 BSL1815X : 15 BSL1820 : 20 BSL1825 : 25 BSL1830C : 30	BSL1830 : 20 BSL1840 : 26 BSL1850 : 32 BSL1860 : 38	BSL36A18 : 32	
USB	Charging voltage	V	5				
	Charging current	A	2				

NOTE

The recharging time may vary according to the ambient temperature and power source voltage.

4. Disconnect the charger's power cord from the receptacle.

5. Hold the charger firmly and pull out the battery.

NOTE

Be sure to pull out the battery from the charger after use, and then keep it.

Regarding electric discharge in case of new batteries, etc.
--

As the internal chemical substance of new batteries and batteries that have not been used for an extended period is not activated, the electric discharge might be low when using them the first and second time. This is a temporary phenomenon, and normal time required for recharging will be restored by recharging the batteries 2 – 3 times.

English

How to make the batteries perform longer.

- (1) Recharge the batteries before they become completely exhausted.
When you feel that the power of the tool becomes weaker, stop using the tool and recharge its battery. If you continue to use the tool and exhaust the electric current, the battery may be damaged and its life will become shorter.
- (2) Avoid recharging at high temperatures.
A rechargeable battery will be hot immediately after use. If such a battery is recharged immediately after use, its internal chemical substance will deteriorate, and the battery life will be shortened. Leave the battery and recharge it after it has cooled for a while.

CAUTION

- If the battery is charged while it is heated because it has been left for a long time in a location subject to direct sunlight or because the battery has just been used, the charge indicator lamp of the charger lights for 0.3 seconds, does not light for 0.3 seconds (off for 0.3 seconds). In such a case, first let the battery cool, then start charging.
- When the charge indicator lamp flickers (at 0.2-second intervals), check for and take out any foreign objects in the charger's battery connector. If there are no foreign objects, it is probable that the battery or charger is malfunctioning. Take it to your authorized Service Center.
- Since the built-in micro computer takes about 3 seconds to confirm that the battery being charged with UC18YSL3 is taken out, wait for a minimum of 3 seconds before reinserting it to continue charging. If the battery is reinserted within 3 seconds, the battery may not be properly charged.

PRIOR TO OPERATION

CAUTION

To avoid serious accident, ensure the switch is in the OFF position, and pull out the battery.

1. Check the work area environment
Check the work area to make sure that it is clear of debris and clutter.
Clear the area of unnecessary personnel. Ensure that lighting and ventilation is adequate.
2. Mounting the blade
This unit employs a detachable mechanism that enables mounting and removal of saw blades without the use of a wrench or other tools.

- (1) Pivot the lever to open the blade clamp.
- (2) Insert the saw blade all the way into the small slit of the blade holder with the lever pivoting. You can mount this blade either in the upward or downward direction. (Fig. 6, Fig. 7)
- (3) When you release the lever, the spring force will return the lever to the correct position automatically.
- (4) Pull the back of the saw blade two or three times by hand and check that the blade is securely mounted. (Fig. 8)

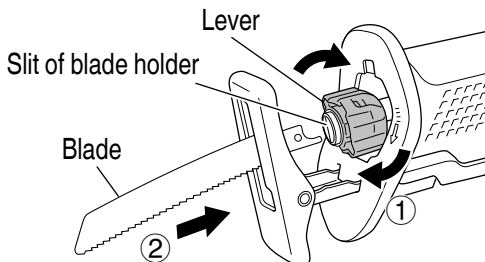

Fig. 6

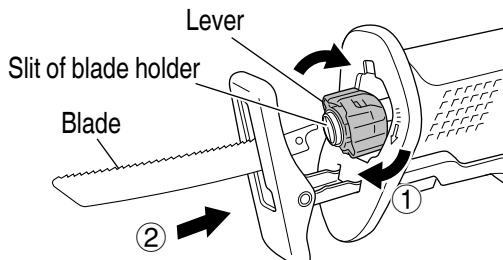

Fig. 7

CAUTION

When pulling the saw blade, be absolutely sure to pull it from the back. Pulling other parts of the blade will result in an injury.

3. Dismounting the blade

CAUTION

Never touch the saw blade immediately after use. The metal is hot and can easily burn your skin.

- (1) After pivoting the lever, point the blade downward. The blade should fall out on its own. If the blade fails to fall out, pull it out by hand.

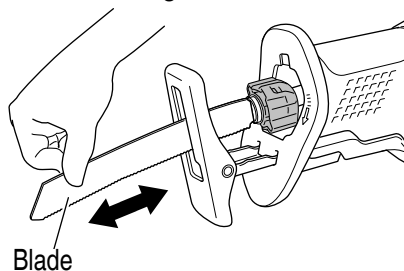

Fig. 8

WHEN THE BLADE IS BROKEN

Even when the saw blade is broken and remains inside the small slit of the blade holder, it should fall out when the lever is pivoted and the blade is pointed downward. If the blade fails to fall out on its own, take it out by using the procedures described below.

- (1) If a part of the broken saw blade is sticking out of the small slit of the blade holder, pull out the protruding part and take the blade out.
- (2) If the broken saw blade is hidden inside the small slit, hook the broken blade using a tip of another saw blade and take it out. (Fig. 9)

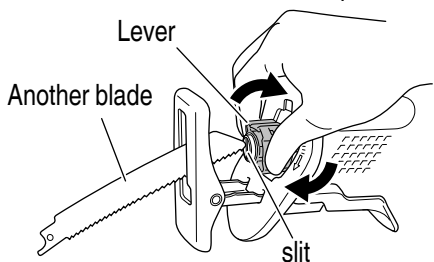

Fig. 9

English

MAINTENANCE AND INSPECTION OF SAW BLADE MOUNT

- (1) After use, blow away sawdust, earth, sand, moisture, etc., with air or brush them away with a brush, etc., to ensure that the blade mount can function smoothly.

NOTE

Continued use of the tool without cleaning the area where the saw blade is attached can result in sawdust and chip buildup which may adversely affect the movement of the lever. Should this be the case, pivot the lever and clean around the blade holder and lever by wiping or blowing away the buildup.

CAUTION

Do not use any saw blade with a worn-out blade hole. Otherwise, the saw blade can come off, resulting in personal injury. (Fig. 10)

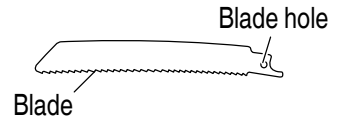

Fig. 10

4. Adjusting the base
To maximize blade life, the base slides in or out to allow the stroke length to be adjusted for better efficiency.
 - (1) Turn off the switch and remove the battery.
 - (2) Pivot the base lever clockwise; and slide the base to the desired position. There are five positions that the base can be adjusted to.
 - (3) Pivot the base lever counterclockwise to secure the base. (Fig. 11)
 - (4) Make sure that the base is not interfering with the blade.

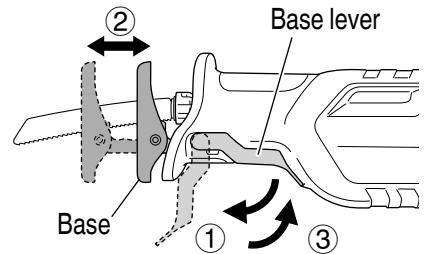

Fig. 11

WARNING

To avoid injury and damage, do not operate the saw without the base in place. The blade holder may strike against the workpiece and damage the reciprocating mechanism.

5. Check battery insertion

WARNING

If the battery is inserted while the power switch is in the ON position, the power tool will start operating immediately, inviting serious accident.

CAUTION

Until the battery locks in place with a little click, if not, it may accidentally fall out of the tool causing injury to you or someone around you.

HOW TO USE

WARNING

Never touch the moving parts.

CAUTION

- Be careful not to let sawdust, earth, moisture, etc., enter the inside of the machine through the plunger section during operation. If sawdust and the like accumulate in the plunger section, always clean it before use.
- Do not remove the front cover. Be sure to hold the body from the top of the front cover (Fig. 12).
- During use, press the base against the material while cutting. Vibration can damage the saw blade if the base is not pressed firmly against the workpiece. Furthermore, a tip of the saw blade can sometimes contact the inner wall of the pipe, damaging the saw blade.
- Select a saw blade of the most appropriate length. Ideally, the length protruding from the base of the saw blade after subtracting the stroke quantity should be larger than the material (see Fig. 13 and Fig. 15). If you cut a large pipe, large block of wood, etc., that exceeds the cutting capacity of a blade; there is a risk that the blade may contact with the inner wall of the pipe, wood, etc., resulting in damage (Fig. 14, Fig. 16).
- To extend the lifetime, the lithium-ion battery equips with the protection function to stop the output. Therefore, if the tool is overloaded, the motor may stop. However, this is not the trouble but the result of protection function. In this case, release the switch of tool and eliminate the causes of overloading.
- Don't remove the tool from workpiece during a cut while the saw blade is moving.
- Pull out the battery after completing operation.

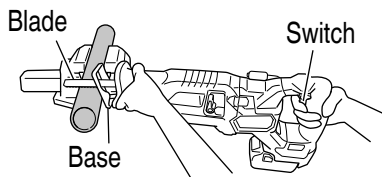

Fig. 12

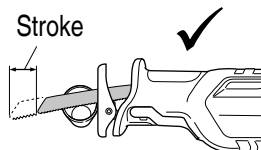

Fig. 13

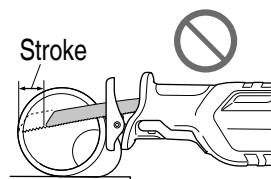

Fig. 14

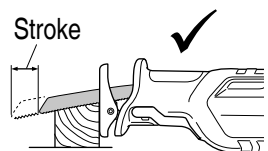

Fig. 15

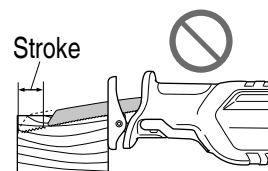

Fig. 16

English

NOTE

Take care not to lock the motor. If the motor is locked, immediately turn the power off. If the motor is locked for a while, the motor or battery may be burnt.

1. Switch operation

(1) Lock-off button

The tool is equipped with a lock-off button. To start the tool, press the lock-off button and then squeeze the trigger switch. (Fig. 17)

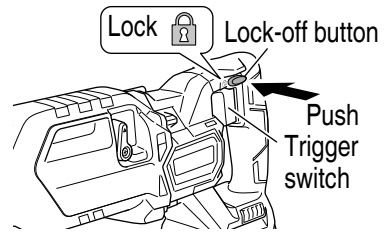

CAUTION

Do not fix and secure the lock-off button. Besides, keep your finger off the trigger switch when the tool is being carried around. Otherwise, the trigger switch can be inadvertently turned ON, resulting in unexpected accidents.

(2) Trigger switch

This tool is equipped with a variable speed controlled trigger switch. The tool can be turned "ON" or "OFF" by squeezing or releasing the trigger. The blade plunger stroke rate can be adjusted from the minimum to maximum nameplate stroke rate by the pressure you apply to the trigger. Apply more pressure to increase the speed and release pressure to decrease speed. (Fig. 18)

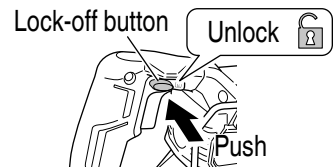

Fig. 17

2. Adjusting operating speed

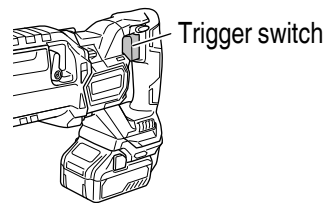

Fig. 18

CAUTION

- Do not subject the switch panel to shock or damage.
- Select mode while the trigger switch is released. Failure to do so could result in malfunction.

The blade's stroke volume can be adjusted to any level depending on how much the unit's switch is pulled in.

Also, the maximum number of strokes can be selected with the mode selector switch. The more the unit's switch is pulled, the higher the number of strokes.

When starting a cut, begin cutting with low strokes (slow speed) to accurately cut the desired position. Once you have the desired cut, raise the number of strokes (high speed) and finish cutting.

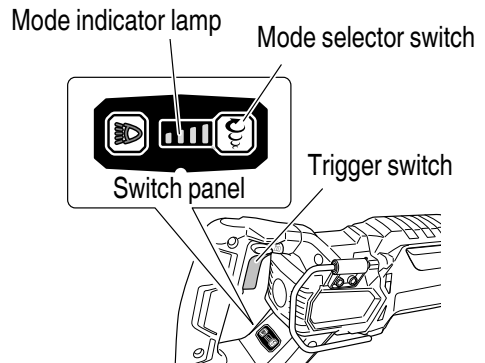

Fig. 19

Once you install the battery and switch on the power, you can change modes with each press of the mode selector switch. (Fig. 20)

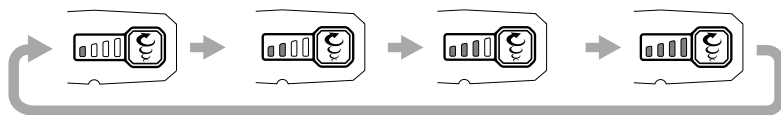

Fig. 20

- Speed change mode allows the number of maximum strokes to be switched between 4 levels: low speed, medium speed, high speed and Max. speed.
With speed change mode, the set number of maximum strokes will be maintained even if there is a change in load.
- **Table 3** shows the lamp status and speed.

Table 3

Mode		State of lamp	Operating speed	Uses
Transmission Mode	Low		0 – 1700 /min	Stainless steel Plastic Fiber board
	Medium		0 – 2000 /min	Mild steel pipes Cast-iron tubes L-shaped angle steel Aluminum / brass / copper
	High		0 – 2500 /min	Plaster board Wood
	Max.		0 – 3000 /min	

NOTE

The mode selector switch can only be set after the battery has been installed in the tool and the trigger switch has been pulled once.

3. Stroke Mode

This power tool features a straight mode in which the blade moves back and forth, and an orbital mode in which the blade moves back and forth while moving up and down. For soft materials such as wood, orbital mode ensures smooth cutting operation while improving the discharge of sawdust and the interlock with materials.

English

Use the change lever to select the ideal mode for the task at hand. (Fig. 21 and Fig. 22)
 The ideal mode depends on factors such as the hardness of the material to be cut and the level of finish required. Use **Table 4** as a guideline when making your choice.

Table 4

Stroke Mode	Straight mode		Orbital mode	
Trajectory of Motion	Back and forth action		Back and forth action + up and down action	
Hardness of Material	Hard material	←————→	←————→	Soft material
Cutting Speed	Slow	←————→	←————→	Fast
Level of Finish	Smooth	←————→	←————→	Rough

NOTE

- Select Straight Mode if you wish to cut soft materials neatly.
- Occasionally clean the change lever as its movement may be adversely affected if dirt or dust collects on the change lever.

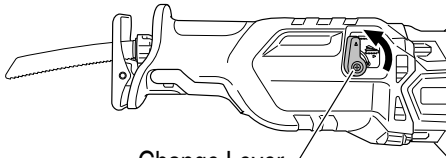

Change Lever
(Straight Mode)

Fig. 21

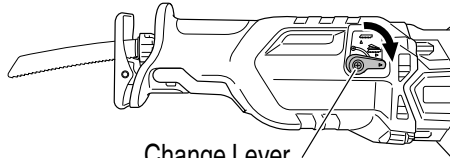

Change Lever
(Orbital Mode)

Fig. 22

4. How to use the Hook
 The hook can be used to hang up the unit temporarily during operations (Fig. 23, Fig. 24).

CAUTION

The hook should never be used to hang the unit on your person.
When using the hook, check to make sure that the main unit will not slip and fall, or become unstable by the wind, etc.
Never hang the unit from your belt or trousers as this could cause accidents.

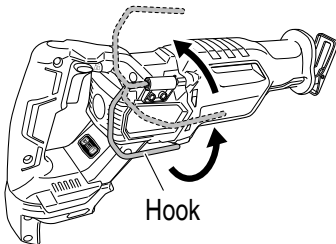

Hook

Fig. 23

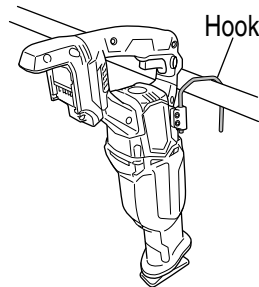

Hook

Fig. 24

5. Cutting metallic materials

CAUTION

- Press the base firmly against the workpiece.
- Never apply any unreasonable force to the saw blade when cutting. Doing so can easily break the blade.
- The motor can be locked sometimes, depending on the combination of the material to be cut and the blade. Whenever the motor gets locked, switch it off immediately.
- Do not operate power tools in explosive atmospheres, such as in the presence of flammable liquids, gases or dust. Reciprocating saw create sparks which may ignite the dust or fumes.

- (1) Fasten a workpiece firmly before operation. (Fig. 25)
- (2) When cutting metallic materials, use proper machine oil (turbine oil, etc.). When not using liquid machine oil, apply grease over the workpiece.

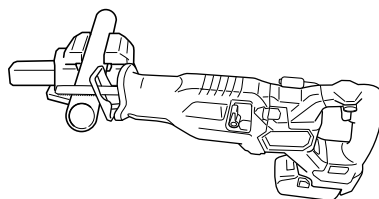

Fig. 25

CAUTION

The service life of the saw blade will be drastically shortened if you don't use machine oil.

6. Cutting lumber
When cutting lumber, make sure that the workpiece is fastened firmly before beginning. (Fig. 26)

CAUTION

Never apply any unreasonable force to the saw blade when cutting. Also remember to press the base against the lumber firmly.

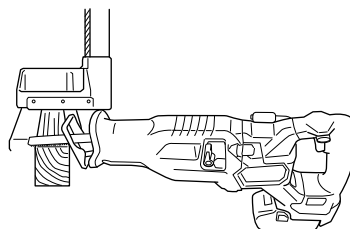

Fig. 26

7. Sawing curved lines
We recommend that you use the BI-METAL blade mentioned in **Table 8 on page 59** for the saw blade since it is tough and hardly breaks.

CAUTION

Delay the feed speed when cutting the material into small circular arcs. An unreasonably fast feed may break the blade.

8. Plunge cutting
With this tool, you can perform plunge cutting on plywood panels and thin board materials. You can carry out plunge cutting quite easily with the saw blade installed in reverse as illustrated in **Fig. 30, Fig. 31, Fig. 32 on page 50**.
Use the saw blade that is as short and thick as possible. We recommend for this purpose that you use BI-METAL Blade No. 132 mentioned in **Table 8 on page 59**. Be sure to use caution during the cutting operation and observe the following procedures.

English

- (1) Press the lower part (or the upper part) of the base against the material. Pull the switch trigger while keeping the tip of the saw blade apart from the material (**Fig. 27, Fig. 30**).
- (2) Raise the handle slowly and cut in with the saw blade little by little (**Fig. 28, Fig. 31**).
- (3) Hold the body firmly until the saw blade completely cuts into the material (**Fig. 29, Fig. 32**).

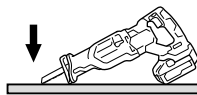

Fig. 27

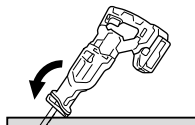

Fig. 28

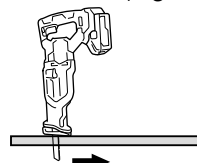

Fig. 29



Fig. 30

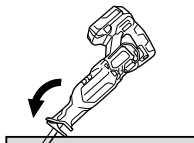

Fig. 31

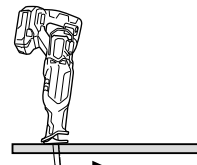

Fig. 32

CAUTION

- Avoid plunge cutting for metallic materials. This can easily damage the blade.
- Never pull the Trigger switch while the tip of the saw blade is pressed against the material. If you do so, the blade can easily be damaged when it collides with the material.
- Make absolutely sure that you cut slowly while holding the body firmly. If you apply any unreasonable force to the saw blade during the cutting operation, the blade can easily be damaged.

9. How to use the LED light

[Normal Use]

The LED light will light the area at the tip of the tool when the switch is drawn.

The LED light will automatically power off 10 seconds after the switch is released.

[Using just the LED light (Lantern Mode)]

Pressing the lighting switch on the switch panel will turn the LED light ON/OFF without having to pull the switch.

To prevent battery consumption, turn the LED light OFF as much as possible.

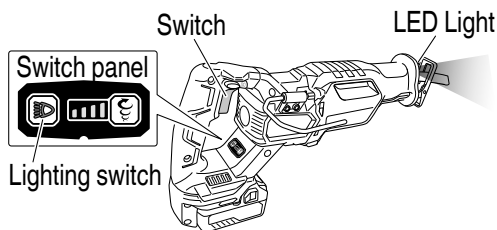

Fig. 33

NOTE

- To prevent battery consumption when the LED light is left on, the light will automatically power off if the switch is untouched for approximately one hour.
- When the switch is pulled, the LED light will switch over to [Normal Use] mode.

CAUTION

- Do not expose directly your eye to the light by looking into the light. If your eye is continuously exposed to the light, your eye will be hurt.
- Wipe off any dirt or grime attached to the lens of the LED light with a soft cloth, being careful not to scratch the lens. Scratches on the lens of the LED light can result in decreased brightness.

10. LED light warning signals (Fig. 34)
This product features functions that are designed to protect the tool itself as well as the battery. While the switch is pulled, if any of the safeguard functions activate during operation, the LED light will blink as described in Table 5.

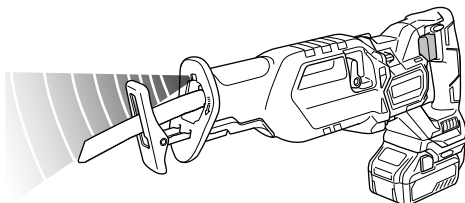

Fig. 34

When any of the safeguard functions are triggered, immediately remove your finger from the switch and follow the instructions described under corrective action

Table 5

Safeguard Function	LED Light Display	Corrective Action
Overburden Protection	On 0.1 second/off 0.1 second ■ ■ ■ ■ ■ ■ ■ ■ ■ ■ ■ ■ ■ ■ ■ ■	Remove the cause of the overburdening.
Temperature Protection	On 0.5 second/off 0.5 second ■ ■ ■ ■ ■ ■ ■ ■ ■ ■ ■ ■ ■ ■ ■ ■	Allow the tool and battery to thoroughly cool.

11. About Remaining Battery Indicator
You can check the battery's remaining capacity by pressing the remaining battery indicator switch to light the indicator lamp. (Fig. 35, Table 6 on page 52)

The indicator will shut off approximately 3 seconds after the remaining battery indicator switch is pressed.

It is best to use the remaining battery indicator as a guide since there are slight differences such as ambient temperature and the condition of the battery.

Also, the remaining battery indicator may vary from those equipped to a tool or charger.

Remaining battery indicator lamp Remaining battery indicator switch

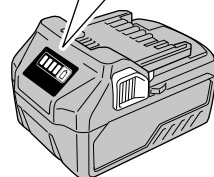
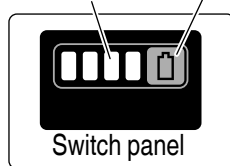

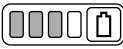

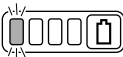

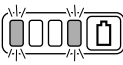

Fig. 35

Table 6

State of lamp	Battery Remaining Power
	Lights ; The battery remaining power is over 75%
	Lights ; The battery remaining power is 50% – 75%.
	Lights ; The battery remaining power is 25% – 50%.
	Lights ; The battery remaining power is less than 25%
	Blinks ; The battery remaining power is nearly empty. Recharge the battery soonest possible.
	Blinks ; Output suspended due to high temperature. Remove the battery from the tool and allow it to fully cool down.
	Blinks ; Output suspended due to failure or malfunction. The problem may be the battery so please contact your dealer.

As the remaining battery indicator shows somewhat differently depending on ambient temperature and battery characteristics, read it as a reference.

NOTE

Do not give a strong shock to the switch panel or break it. It may lead to a trouble.

OPERATIONAL CAUTIONS

Resting the unit after continuous work

- (1) The power tool is equipped with a temperature protection circuit to protect the motor. Continuous work may cause the temperature of the unit to rise, activating the temperature protection circuit and automatically stopping operation. If this happens, allow the power tool to cool before resuming use.
- (2) After use for continuous works, rest the unit for 15 minutes or so when replacing the battery. The temperature of the motor, switch, etc., will rise if the work is started again immediately after battery replacement, eventually resulting in burnout.

HOW TO RECHARGE USB DEVICE

WARNING

- **Prior to use, check the connecting USB cable for any defect or damage. Using a defective or damaged USB cable can cause smoke emission or ignition.**
- **When the product is not being used, cover the USB port with the rubber cover. Buildup of dust etc. in the USB port can cause smoke emission or ignition.**

NOTE

- There may be an occasional pause during USB recharging.
 - When a USB device is not being charged, remove the USB device from the charger. Failure to do so may not only reduce the battery life of a USB device, but may also result in unexpected accidents.
 - It may not be possible to charge some USB devices, depending on the type of device.
- (1) Select a charging method
Depending on the charge method selected, either the battery is inserted into the charger or the power cord is plugged into an outlet.
- Charging a USB device from a electrical outlet (Fig. 36-a).
 - Charging a USB device and battery from a electrical outlet.(Fig. 36-b)

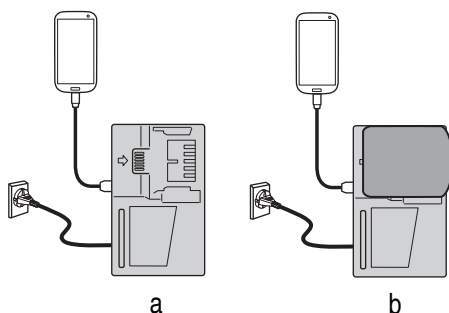
**Fig. 36**

- (2) Connect the USB cable. (Fig. 37)
Pull back the rubber cover and firmly plug in a commercially available USB cable (appropriate to the device being charged) into the USB port.

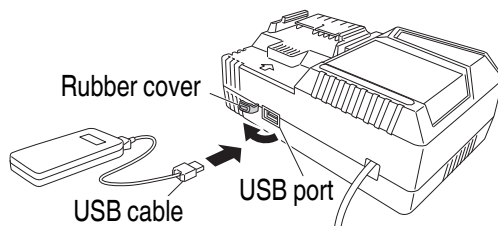
**Fig. 37**

- (3) When charging is completed
- To verify charge status, check the USB device.
 - Unplug the power cord from the electrical outlet. (Fig. 38)
 - Place the rubber cover over the USB port.

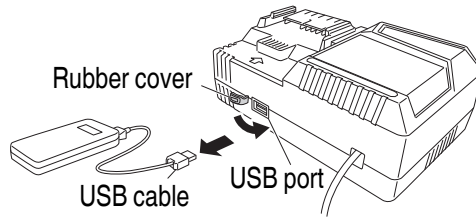

Fig. 38

MAINTENANCE AND INSPECTION

CAUTION

Be sure to turned off the switch and remove the battery before maintenance and inspection.

1. Inspecting the blade
Continued use of a dull or damaged blade will result in reduced cutting efficiency and may cause overloading of the motor. Replace the blade with a new one as soon as excessive abrasion is noted.

CAUTION

If a dull saw blade is used, reactive force is increased during cutting operation. Avoid the use of the dull saw blade without repair.

2. Inspecting the mounting screws
Regularly inspect all mounting screws and ensure that they are properly tightened. Should any of the screws be loose, retighten them immediately. Failure to do so could result in serious hazard.
3. Maintenance of the motor
The motor unit winding is the very "heart" of the power tool. Exercise due care to ensure the winding does not become damaged and/or wet with oil or water.
4. Inspection of terminals (tool and battery)
Check to make sure that swarf and dust have not collected on the terminals. On occasion check prior, during and after operation.

CAUTION

Remove any swarf or dust which may have collected on the terminals. Failure to do so may result in malfunction.

5. Cleaning of the outside
When the Cordless Reciprocating Saw is stained, wipe with a soft dry cloth or a cloth moistened with soapy water. Do not use chloric solvents, gasoline or paint thinner, as they melt plastics.

6. Lubrication

The bearings in this tool have been sufficiently lubricated with quality lubricating oil, taking into account the expected life of this tool under normal operating conditions. As a result, no further lubrication is necessary.

7. Storage

Store the Cordless Reciprocating Saw in a place in which the temperature is less than 40°C, and out of reach of children.

NOTE

Storing Lithium-ion Batteries

Make sure the batteries have been fully charged before storing them.

Prolonged storage (3 months or more) of batteries with a low charge may result in performance deterioration, significantly reducing battery usage time or rendering the batteries incapable of holding a charge.

However, significantly reduced battery usage time may be recovered by repeatedly charging and using the batteries two to five times.

If the battery usage time is extremely short despite repeated charging and use, consider the batteries dead and purchase new batteries.

CAUTION

In the operation and maintenance of power tools, the safety regulations and standards prescribed in each country must be observed.

Important notice on the batteries for the HiKOKI cordless power tools

Please always use one of our designated genuine batteries. We cannot guarantee the safety and performance of our cordless power tool when used with batteries other than these designated by us, or when the battery is disassembled and modified (such as disassembly and replacement of cells or other internal parts).

TROUBLESHOOTING

Use the inspections in the table below if the tool does not operate normally. If this does not remedy the problem, consult your dealer or the HiKOKI Authorized Service Center.

1. Power tool

Symptom	Possible cause	Remedy
Tool doesn't run	No remaining battery power	Charge the battery.
Tool suddenly stopped	Tool was overburdened	Get rid of the problem causing the overburden. During operation, lighten the applied pressure.
	Battery or tool overheated	Allow the tool and battery to thoroughly cool.
	The trigger switch was held down for 5 minutes or more.	This is not a malfunction. The motor was automatically stopped to prevent failure of the tool.
Saw blade - can't be attached - fall off	The shape of the attachment portion doesn't match	Use the appropriate blade (See "OPTIONAL ACCESSORIES" on page 38)
	The blade's attachment hole is worn	Replace with a new blade.
Switch can't be pulled	Lock-off button is pushed in	Release the Lock-off button.
An abnormal high-pitched noise occurs when the trigger switch is pulled.	The trigger switch is being pulled only slightly.	This is not a malfunction. It does not occur if the trigger switch is pulled more fully.
Blade wears out too quickly.	Number of strokes is too fast Mode is inappropriate	Switch the mode to a lower setting than the current one. (Switch to low speed mode when cutting stainless pipes) (See "Adjusting operating speed" on page 46)
	Proper machine oil not used when cutting metallic materials	Use machine oil (turbine oil, etc.)
	Too much applied pressure during operation	During operation, lighten the applied pressure.

Symptom	Possible cause	Remedy
Unable to properly cut.	Blade is inappropriate for the quality and thickness of the material to be cut	Use the proper blade (See "OPTIONAL ACCESSORIES" on page 38)
	Blade is too short for the length of the material to be cut	
	Mode is inappropriate for the quality and thickness of the material to be cut	Set the appropriate mode (See "Adjusting operating speed" on page 46)
	Blade is worn, degraded or damaged	Replace with a new blade.
Battery cannot be installed	Attempting to install a battery other than that specified for the tool.	Please install a multi volt type battery.

2. Charger

Symptom	Possible cause	Remedy
The charge indicator lamp rapidly flickers purple, and battery charging doesn't begin.	The battery is not inserted all the way.	Insert the battery firmly.
	There is foreign matter in the battery terminal or where the battery is attached.	Remove the foreign matter.
The charge indicator lamp blinks red, and battery charging doesn't begin.	The battery is not inserted all the way.	Insert the battery firmly.
	The battery is overheated.	If left alone, the battery will automatically begin charging if its temperature decreases, but this may reduce battery life. It is recommended that the battery be cooled in a well-ventilated location away from direct sunlight before charging it.
Battery usage time is short even though the battery is fully charged.	The battery's life is depleted.	Replace the battery with a new one.

English

Symptom	Possible cause	Remedy
The battery takes a long time to charge.	The temperature of the battery, the charger, or the surrounding environment is extremely low.	Charge the battery indoors or in another warmer environment.
	The charger's vents are blocked, causing its internal components to overheat.	Avoid blocking the vents.
	The cooling fan is not running.	Contact a HiKOKI Authorized Service Center for repairs.
The USB power lamp has switched off and the USB device has stopped charging.	The battery's capacity has become low.	Replace the battery with one that has capacity remaining.
		Plug the charger's power plug into an electric socket.
USB power lamp does not switch off even though the USB device has finished charging.	The USB power lamp lights up green to indicate that USB charging is possible.	This is not a malfunction.
It is unclear what the charging status of a USB device is, or whether its charging is complete.	The USB power lamp does not switch off even when charging is complete.	Examine the USB device that is charging to confirm its charging status.
Charging of a USB device pauses midway.	The charger was plugged into an electrical socket while the USB device was being charged using the battery as the power source.	This is not a malfunction. The charger pauses USB charging for about 5 seconds when it is differentiating between power sources.
	A battery was inserted into the charger while the USB device was being charged using a power socket as the power source.	
Charging of the USB device pauses midway when the battery and the USB device are being charged at the same time.	The battery has become fully charged.	This is not a malfunction. The charger pauses USB charging for about 5 seconds while it checks whether the battery has successfully completed charging.

Symptom	Possible cause	Remedy
Charging of the USB device doesn't start when the battery and the USB device are being charged at the same time.	The remaining battery capacity is extremely low.	This is not a malfunction. When the battery capacity reaches a certain level, USB charging automatically begins.

SELECTION OF BLADES

To ensure maximum operating efficiency and results, it is very important to select the appropriate blade best suited to the type and thickness of the material to be cut.

NOTE

Dimensions of the workpiece mentioned in the table represent the dimensions when the mounting position of the base is set nearest to the body of the Cordless Reciprocating Saw. Caution must be exercised since dimensions of the workpiece will become smaller if the base is mounted far away from the body of the Cordless Reciprocating Saw.

1. Selection of HCS blades

The blade number of HCS blades in **Table 7** is engraved in the vicinity of the mounting position of each blade. Select appropriate blades by referring to **Tables 7 and 9 on page 60** below.

Table 7: HCS blades

Blade No.	Uses	Thickness (mm)
No. 4	For cutting and roughing lumber	50 – 70
No. 5	For cutting and roughing lumber	Below 30
No. 95	For cutting stainless steel pipe less than 100 mm in diameter	Below 2.5
No. 96	For cutting stainless steel pipe less than 30 mm in diameter	Below 2.5

NOTE

No. 4 – No. 96 HCS blades are sold separately as optional accessories.

2. Selection of BI-METAL blades

The BI-METAL blade numbers in **Table 8** are described on the packages of special accessories. Select appropriate blades by referring to **Table 8 and 9 on page 60** below.

Table 8: BI-METAL blades

Blade No.	Uses	Thickness (mm)
No. 101 No. 103 No. 109 No. 141(S)	For cutting steel and stainless pipes less than 60 mm in outer diameter	2.5 – 6

English

No. 102 No. 104 No. 110 No. 142(S) No. 143(S)	For cutting steel and stainless pipes less than 100 mm in outer diameter	2.5 – 6
No. 107	For cutting steel and stainless pipes less than 60 mm in outer diameter	Below 3.5
No. 108	For cutting steel and stainless pipes less than 100 mm in outer diameter	Below 3.5
No. 121	For cutting and roughing lumber	100
No. 131	All purpose	100
No. 132	All purpose	100

NOTE

No. 101 – No. 132 BI-METAL blades are sold separately as optional accessories.

3. Selection of blades for other materials

Table 9

Material to be cut	Material quality	Thickness (mm)	Blade No.
Iron plate	Mild steel plate	2.5 – 10	No. 101, 102, 103, 104, 109, 110, 131, 141(S), 142(S), 143(S)
		Below 3.5	No. 107, 108
Nonferrous metal	Aluminium, Copper and Brass	5 – 20	No. 101, 102, 103, 104, 109, 110, 131, 132, 141(S), 142(S), 143(S)
		Below 5	No. 107, 108
Synthetic resin	Phenol resin, Melamine resin, etc.	10 – 50	No. 101, 102, 103, 104, 131, 132, 141(S), 142(S), 143(S)
		5 – 30	No. 107, 108, 109, 110
	Vinyl chloride, Acrylic resin, etc.	10 – 60	No. 101, 102, 103, 104, 131, 132, 141(S), 142(S), 143(S)
		5 – 30	No. 107, 108, 109, 110

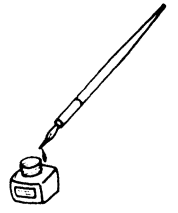

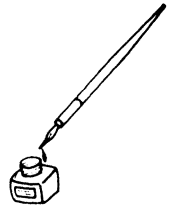

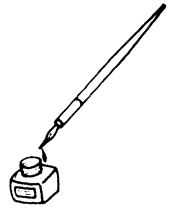

服务中心
高壹工机商业(上海)有限公司
上海市闵行区浦江工业园区三鲁路3585号7幢3楼

制造商
广东高壹工机有限公司
广东省广州市番禺区化龙镇工业路富裕围工业村

Koki Holdings Co., Ltd.

109
编号: C99730623 G
发行日期: 2021年9月
中国印刷