

HIKOKI

电圆锯
Circular Saw

C 7U3

中文
English

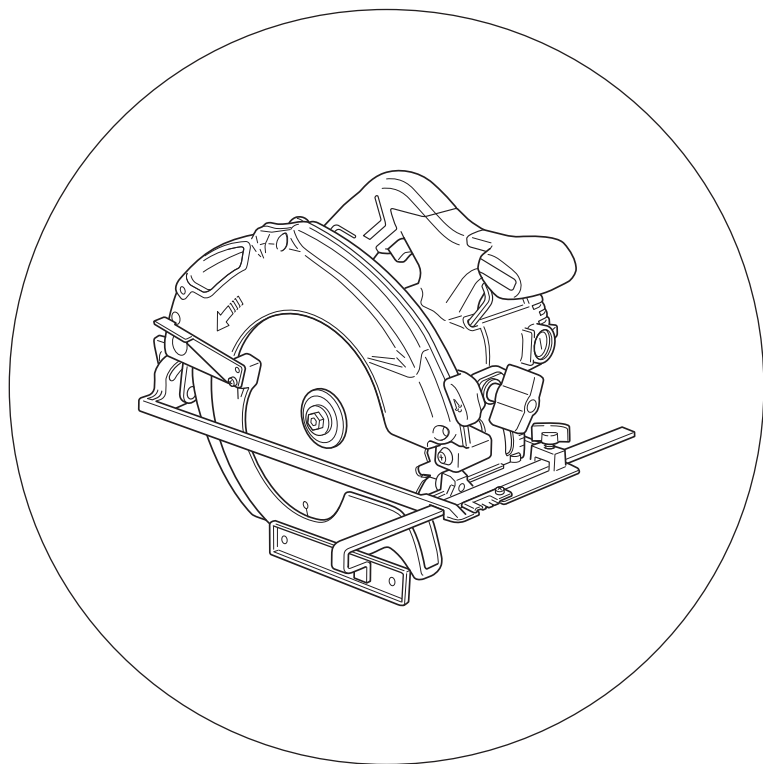

保留备用
Keep for future reference



使用说明书
Handling instructions



目次

电动工具通用安全警告	2	用途.....	8
所有圆锯的安全说明.....	4	作业之前.....	9
所有圆锯的进一步安全说明.....	5	使用前调整电圆锯.....	9
带摆动式内护罩的圆锯的安全说明.....	6	锯割步骤.....	11
带分料刀的各种圆锯的附加安全说明.....	6	锯片的装卸.....	12
使用电圆锯时应注意事项.....	7	使用固线器.....	13
符号.....	7	维护和检查.....	13
规格.....	8	附加信息.....	14
标准附件.....	8	选择附件.....	15

电动工具通用安全警告

警告！

阅读随电动工具提供的所有安全警告、说明、图示和规定。
不遵照以下所列说明会导致电击、着火和 / 或严重伤害。

保存所有警告和说明书以备查阅。

在所有下列的警告中术语“电动工具”指市电驱动(有线)电动工具或电池驱动(无线)电动工具。

a) 工作场地的安全

- 1) 保持工作场地清洁和明亮。
杂乱和黑暗的场地会引发事故。
- 2) 不要在易爆环境，如有易燃液体、气体或粉尘的环境下操作电动工具。
电动工具产生的火花会点燃粉尘或气体。
- 3) 操作电动工具时，远离儿童和旁观者。
注意力不集中会使你失去对工具的控制。

b) 电气安全

- 1) 电动工具插头必须与插座相配。绝不能以任何方式改装插头。需接地的电动工具不能使用任何转换插头。
未经改装的插头和相配的插座将降低电击风险。
- 2) 避免人体接触接地表面，如管道、散热片和冰箱。
如果你身体接触接地表面会增加电击风险。
- 3) 不得将电动工具暴露在雨中或潮湿环境中。
水进入电动工具将增加电击风险。

- 4) 不得滥用软线。绝不能用软线搬运、拉动电动工具或拔出其插头。使软线远离热源、油、锐边或运动部件。
受损或缠绕的软线会增加电击风险。
- 5) 当在户外使用电动工具时，使用适合户外使用的延长线。
适合户外使用的电线将降低电击风险。
- 6) 如果无法避免在潮湿环境中操作电动工具，应使用带有剩余电流装置（RCD）保护的电源。
RCD的使用可降低电击风险。

c) 人身安全

- 1) 保持警觉，当操作电动工具时关注所从事的操作并保持清醒。当你感到疲倦，或在有药物、酒精或治疗反应时，不要操作电动工具。
在操作电动工具时瞬间的疏忽会导致严重人身伤害。
- 2) 使用个人防护装置。始终佩戴护目镜。
防护装置，诸如适当条件下使用防尘面具、防滑安全鞋、安全帽、听力防护等装置能减少人身伤害。
- 3) 防止意外起动。在连接电源和 / 或电池包、拿起或搬运工具前确保开关处于关断位置。
手指放在开关上搬运工具或开关处于接通时通电会导致危险。
- 4) 在电动工具接通之前，拿掉所有调节钥匙或扳手。
遗留在电动工具旋转零件上的扳手或钥匙会导致人身伤害。
- 5) 手不要过分伸展。时刻注意立足点和身体平衡。
这样能在意外情况下能更好地控制住电动工具。
- 6) 着装适当。不要穿宽松衣服或佩戴饰品。让你的头发和衣服远离运动部件。
宽松衣服、佩饰或长发可能会卷入运动部件。
- 7) 如果提供了与排屑、集尘设备连接用的装置，要确保其连接完好且使用得当。
使用集尘装置可降低尘屑引起的危险。
- 8) 不要因为频繁使用工具而产生的熟悉感而掉以轻心，忽视工具的安全准则。
某个粗心的动作可能在瞬间导致严重的伤害。

d) 电动工具使用和注意事项

- 1) 不要勉强使用电动工具，根据用途使用合适的电动工具。
选用合适的按照额定值设计的电动工具会使你工作更有效、更安全。
- 2) 如果开关不能通过或关断电源，则不能使用该电动工具。
不能用开关来控制的电动工具是危险的且必须进行修理。
- 3) 在进行任何调节、更换附件或贮存电动工具之前，必须从电源上拔掉插头和 / 或卸下电池包（如可拆卸）。
这种防护性的安全措施降低了电动工具意外起动的风险。
- 4) 将闲置不用的电动工具贮存在儿童所及范围之外，并且不允许不熟悉电动工具和不了解这些说明的人操作电动工具。
电动工具在未经培训的使用者手中是危险的。

中文

- 5) 维护电动工具及其附件。检查运动部件是否调整到位或卡住，检查零件破损情况和影响电动工具运行的其他状况。如有损坏，应在使用前修理好电动工具。

许多事故是由维护不良的电动工具引发的。

- 6) 保持切削刀具锋利和清洁。

维护良好的有锋利切削刃的刀具不易卡住而且容易控制。

- 7) 按照使用说明书，并考虑作业条件和要进行的作业来选择电动工具、附件和工具的刀头等。

将电动工具用于那些与其用途不符的操作可能会导致危险情况。

- 8) 不要因为频繁使用工具而产生的熟悉感而掉以轻心，忽视工具的安全准则。某个粗心的动作可能在瞬间导致严重的伤害。

e) 维修

- 1) 由专业维修人员使用相同的备件维修电动工具。

这将保证所维修的电动工具的安全。

注意！

不可让儿童和体弱人士靠近工作场所。

应将不使用的工具存放在儿童和体弱人士接触不到的地方。

所有圆锯的安全说明

锯割步骤：

危险！

- a) 让手始终远离锯割区域和锯片。另一只手始终握住辅助手柄或电动机机壳。
如果双手都握住圆锯，就不会切到手。
- b) 不得接触工件的下面。
护罩不能防止工件下方锯片的危险。
- c) 将锯割深度调至工件的厚度。
能看到在工件下方露出的锯齿应不到一个齿高。
- d) 不得手持工件或将工件架在腿上进行锯割，应将工件固定在一个稳定的平台上。
适当支撑工件对减少人身伤害、锯片卡住或操作失控是至关重要的。
- e) 当在锯割附件可能触及暗线或其自身导线的场合进行操作时，要通过绝缘握持面握持工具。
锯割附件碰到带电导线会使工具外露的金属零件带电而使操作者受到电击。
- f) 当作劈锯时，始终使用劈锯护栏和直边导向器。
这样会改善锯割精度并减小了锯片卡住的几率。
- g) 始终使用具有正确轴孔尺寸和形状（方形或圆形）的锯片。
如果锯片与圆锯夹装部件不符将引起偏心运转而导致失控。

h) 不得使用损坏的或尺寸不符的垫圈或螺栓。

为达到最佳操作性能并确保安全操作，锯片垫圈及螺栓是为所使用的圆锯专门设计的。

所有圆锯的进一步安全说明

回弹的原因和相关警告：

- 回弹是当锯片受挤压、被卡住或偏离中心时受到的突然反作用，使圆锯不受控制地抬起并脱离工件冲向操作者。
- 当锯片受挤压或被收拢的切口紧紧卡住时，锯片堵转且电动机反作用力驱使整机向操作者快速弹回。
- 如果锯片发生扭曲或偏离锯割面，锯片后边缘上的锯齿会挖入木材上表面从而使锯片爬出切口并向操作者回弹。

回弹是误用圆锯和 / 骤不正确操作程序或条件导致的结果，采取以下适当预防措施可避免回弹。

- a) 双手紧握圆锯的把手，双臂放置得能抵住回弹力。身体处于圆锯的任意一侧，不要对准锯片。
回弹会导致圆锯向后弹起，但如果采取适当的防备措施，操作者可以控制住回弹力。
- b) 当锯片卡住，或因任何原因导致锯割中断时，释放开关扳机并保持圆锯在材料中不移动，直到锯片完全停止。不得在锯片处于运转或可能发生回弹的情况下尝试将圆锯从工件中移出或向后拉动圆锯。
调查并采取纠正措施以消除锯片卡住的原因。
- c) 当在工件中重新启动圆锯时，将锯片对准切口而不使锯齿插入材料中。
如果锯片卡住了，工具重新启动时，锯片会爬出工件或从工件上回弹。
- d) 支撑大型板料以减少锯片受挤压和回弹的风险。
大型板料会因自重而下垂，支撑物必须放置在板料下面的两侧，靠近锯割线和板料边缘。
- e) 不得使用不锋利的或安装不当的锯片。
没有开锋的或安装不当的锯片会形成窄小的切口，从而导致过度摩擦、锯片卡住和回弹。
- f) 锯割之前，必须旋紧和紧固锯割深度和倾斜角调节锁定钮。
如果锯割时锯片调节器发生移动，可能会引起锯片卡住和回弹。
- g) 当对现存墙体或其他盲区进行锯割时要格外小心。
伸出的锯片可能锯割到会引起回弹的物体。

带摆动式内护罩的圆锯的安全说明

下护罩功能：

- a) 每次使用前，检查下护罩闭合是否自如。如果下护罩不能自如活动并迅速闭合，则不得操作圆锯。不得将下护罩夹住或系绑在开启位置。
如果圆锯意外跌落，下护罩可能会弯曲变形，用回缩手柄抬起下护罩，确信在任何锯割角度和深度下护罩活动自如，且不会触及锯片或任何其他零件。
- b) 检查下护罩弹簧的工作情况，如果护罩及弹簧不能正常工作，必须在使用前对其进行维修。
下护罩可能因零件损害、胶质沉积或废屑堆积而运动迟缓。
- c) 仅当特殊锯割，例如“插入式锯割”和“组合式锯割”，才可用手动方式抬起下护罩。用回缩手柄抬起下护罩，一旦锯片进入到锯割材料就必须立即释放下护罩。
对所有其他锯割作业，下护罩应自动工作。
- d) 在把圆锯放置在工作台或地上之前，应始终察看下护罩是否遮住锯片。
没有防护的、惯性运转的锯片会引起圆锯后退，锯割到其行程上的任何物体。
要考虑到开关释放后锯片停下来的时间。

带分料刀的各种圆锯的附加安全说明

分料刀功能：

- a) 使用与所用分料刀相匹配的锯片。
为使分料刀起作用，锯片本体必须比分料刀薄，锯片锯割宽度应大于分料刀的厚度。
- b) 按使用说明书所述调节分料刀。
不正确的间隔、定位和对准会导致分料刀不能有效地防止回弹。
- c) 除进行“插入式锯割”以外，都要使用分料刀。
必须在插入式锯割之后重新装上分料刀。插入锯割作业期间，分料刀会对锯割造成干扰并产生回弹。

注：

本条警告不适用于带弹簧加载分料刀的插入式圆锯。

- d) 为使分料刀工作，必须将它插入工件。
在进行短材料锯割时，分料刀对防止回弹不起作用。
- e) 当分料刀弯曲变形时不得操作圆锯。
即使一个轻微干涉也会减慢护罩闭合速度。

使用电圆锯时应注意事项

1. 请勿使用破损或变形的锯片。
2. 请勿使用高速钢制造的锯片。
3. 请勿使用不符合本说明书规定特性的锯片。
4. 请勿按压圆盘侧面停止锯片操作。
5. 经常保持锯片锋利。
6. 确保下部防护移动顺畅自如。
7. 请勿在电圆锯的下部防护被固定在打开位置的状态下使用电圆锯。
8. 确保防护系统的收回机制正确操作。
9. 锯片本身必须比分料刀薄，锯割宽度或切口（锯齿）必须比分料刀的厚度大。
10. 请勿在锯片转向前面或转向侧面的状态下使用电圆锯。
11. 确保工件上无铁钉等任何异物。
12. 除在插入工件中间时以外，应一直使用分料刀。
13. 对于型号 C7U3，锯片应在 185 mm 至 190 mm 之间。
 本体厚度：最大 1.5 mm，端部宽度：至少 1.9 mm
 分料刀厚度：1.8 mm
14. 在执行任何调整、维修、维护前先从插座上拔下插头。
15. 请勿仅使用工具的鼓风机功能。（图 1）
16. 请勿使用本机规定的锯片直径以外的锯片。
17. 请勿使用砂轮。
18. 检查线缆上是否有裂口或划痕。
19. 检查外观，确保无破损。
20. 使用锯割木材用切削锯。
21. 使用显示速度不低于工具上显示转速的切削锯。
22. 始终握牢工具把手。



图 1

符号

警告！

如下所示的符号用于本机。使用前请务必理解其含意。

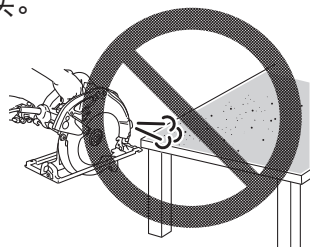



为降低伤害风险，用户必须阅读使用说明书

规格

电压		220 V ~
锯切深度	90 度	0 - 66 mm
	45 度	最大 48 mm
输入功率		1300 W
空载转速		5800 /min
重量 (不含线缆)		4.7 kg

标准附件

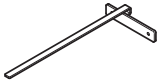
除了主机 (1 台) 外, 产品包中还包括表中所列的附件。

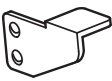
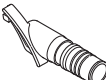
六角条形扳手		1
引导器		1
蝶形螺栓		1
锁簧		1
杆 (短型)		1
集尘器装置		1

用途

锯割各种木材。

作业之前

1. 电源

确认所使用的电源与工具铭牌上标示的规格是否相符。

2. 电源开关

确认电源开关是否切断。若电源开关接通，则插头插入电源插座时电动工具将出其不意地立刻转动，从而招致严重事故。

3. 延伸线缆

若作业场所移到离开电源的地点，应使用容量足够、铠装合适的延伸线缆，并且要尽可能地短些。

4. 制备木质工作台（图 2）

锯片将露出锯木下面，所以锯割时，应将锯木放在工作台上。若用方木块作为工作台，则应选择平坦地面，以保持稳定。使用不稳定的工作台，工作时非常危险。



图 2

注意！

为避免可能发生的事故，锯割后的锯木剩余部分栓住放妥。

使用前调整电圆锯

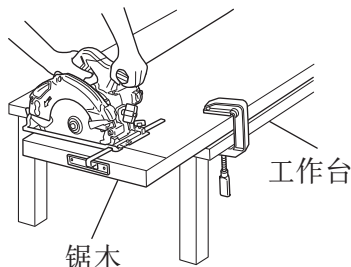
1. 调整锯割深度

如图 3 所示，用一只手握住手柄，另一只手拧松旋钮。

可以通过将底座移到所需的位置来调整锯割深度。以这种方式调整锯割深度后重新拧紧旋钮。



图 3

注意！

如果旋钮一直处于松动状态，则会引发非常危险的状况。务必随时使其完全夹紧。

2. 调整分料刀

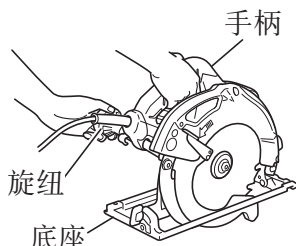
将工具的切割深度设为最小。

拧松夹住分料刀的六角承座螺栓，调整分料刀以使分料刀与锯片齿圈之间的距离不超过 3 mm，锯片齿圈超出分料刀下缘（图 4）不大于 3 mm，然后重新拧紧六角承座螺栓。



图 4

3. 调整倾斜角度

如图 5、图 6 所示拧松斜规上的蝶形螺帽和底座上的蝶形螺栓，根据底座的情况，锯片可能倾斜至 45 度的最大角度。完成调整之后，确认蝶形螺帽和蝶形螺栓是否拧紧。

注意！

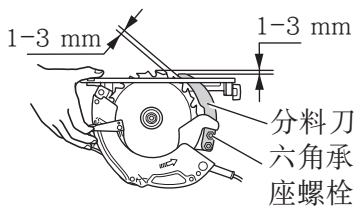
如果蝶形螺栓一直处于松动状态，则会非常危险。务必随时使其完全夹紧。



图 5



图 6

4. 调整引导器 (图 7)

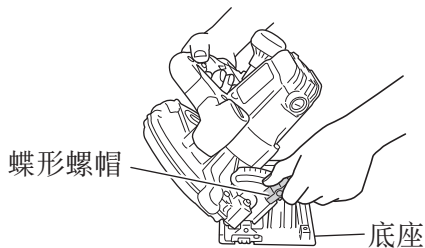
拧松蝶形螺栓，将引导器左右移动，即可调整锯割位置。

引导器可以安装在工具的左边或右边。

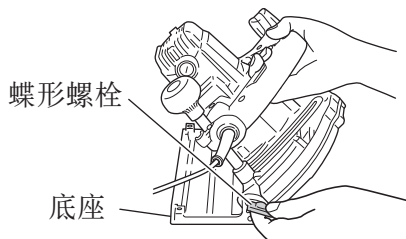
5. 调整导向器

在圆锯机上，可进行导向器固定位置之微调，此微调之位置须先将锯片与记号线对准。

圆锯机从工厂出货后，导向器上的前段线性比例尺会与锯片的中央部位对准 (图 8)。

万一固定位置是错误的话，请松开导向器上的 M4 螺丝，做必要的调整。



图 7



图 8

6. 使用集尘器装置

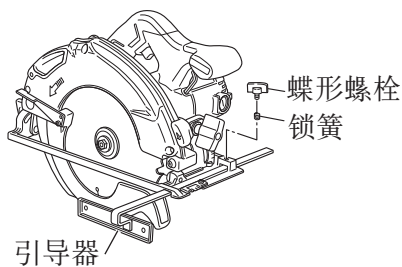
在电动工具上安装真空集尘器后，集尘器装置将收集锯屑。拆下安装在电动工具上的杆并安装杆（短型）。

用 M4 螺丝将集尘器装置安装到电动工具上（图 9）。

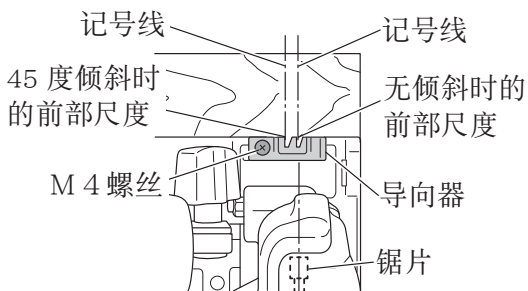

图 9

锯割步骤

1. 将底座置于工件材料上方，然后在底座前方，将锯片及导向器前段线性刻度尺对准于记号线（图 8）。

底座无倾斜角度时，请使用大截面部位以做为导引之用（图 8 和图 10）。

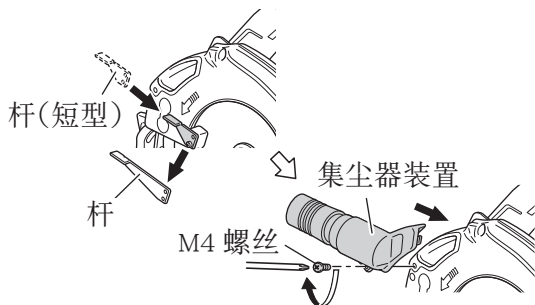
如果有倾斜角度（45 度）时，请以小的前段刻度尺做为导引之用（图 8 和图 11）。



图 10



图 11

2. 锯片在开始进行锯切材料之前，务必先将开关切换至开启（ON）的位置。扳动扳机时即可将开关切换至开启（ON）而松开扳机时便可将开关切换至关闭（OFF）。

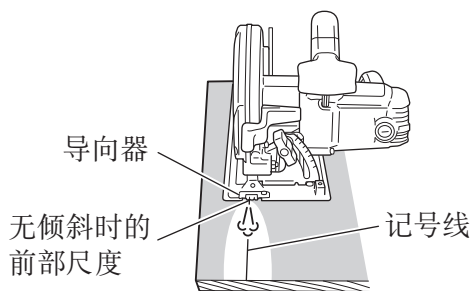
中文

3. 以定速笔直移动电圆锯可进行最佳锯割。

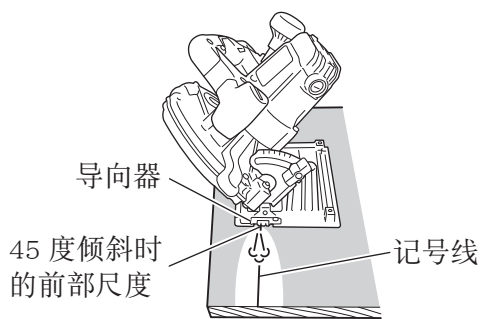
注意！

在进行锯割操作前，请确认要锯割的材料。如果材料有可能产生有害 / 有毒的粉尘，请确保集尘袋或适用的除尘设备已紧密连接到粉尘出口。

如可以，请戴防尘面罩。

- 在开始锯割之前，先确认锯片以达到全速转速。
- 工作中若锯片停止下来或发出异常噪声，应立即关掉开关。
- 随时注意不要让第一线靠近转动着的锯片。
- 锯片朝上或朝侧面使用电圆锯是非常危险的。这种不正常的用途应予避免。
- 锯割材料时，务请戴上护目镜。
- 完成作业时，应将插头从电源插座拔出。

锯片的装卸

注意！

为了避免发生严重事故，务必将开关置于关闭（OFF）位置，并把电源切断。

1. 拆卸锯片

- (1) 将锯割深度调到最大，将电圆锯如图 12 所示放置。
- (2) 压住锁紧杆，锁住主轴，然后用六角条形扳手拆下内六角螺栓。
- (3) 握住下部防护杆以使下部防护完全缩回到锯盖内，拆下锯片。

2. 安装锯片

- (1) 将主轴、螺栓以及垫圈周围聚集的切屑完全清理干净。
- (2) 如图 13 所示，带凸起中心的垫圈（A）侧，其直径和锯片的内径相同，而垫圈（B）的凹入侧必须和锯片侧一致。
- (3) 为确保锯片转动方向正确，锯片上的箭头方向必须与锯盖上的箭头方向一致。
- (4) 用手指尽量将固定锯片的内六角螺栓拧紧。然后压下锁紧杆，锁住主轴，并拧紧螺栓。

注意！

安装锯片后，请再次确认锁紧杆已牢固固定在指定位置。



图 12



图 13

使用固线器

使用固线器可以将电线绕到产品背面，如图所示。如果电线在操作过程中比较碍事，请将其卷入固线器并改变其角度。

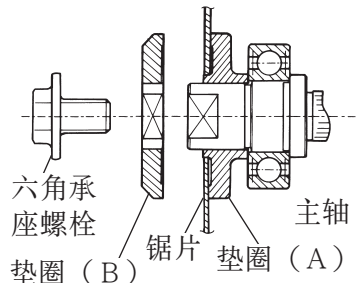

图 14

维护和检查

1. 检查锯片

使用钝锯片将会导致降低效率和电动机故障，因此当查出锯片有磨损时，请尽快磨砺或更换新的。

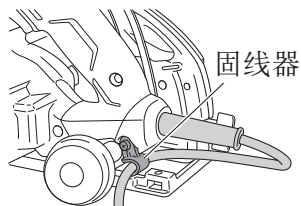
2. 检查安装螺钉

要经常检查安装螺钉是否紧固妥善。若发现螺钉松了，应立即重新扭紧，否则会导致严重的事故。

3. 检查炭刷（图 15）

马达使用炭刷，它是消耗部品，因为使用过久的炭刷将会导致马达故障，用具有相同炭刷号的新炭刷去更换旧的，炭刷编号用数字表示炭刷何时用旧或接近于磨损极限，此外，要经常保持炭刷清洁以及保证它在刷握里能自由滑动。

注意！

在更换新的炭刷前，请按照分解图上指定的数字使用HiKOKI指定的炭刷。



图 15

4. 更换炭刷

用无头螺丝刀卸下炭刷盖，然后可以很容易地取下炭刷。

5. 更换电源线

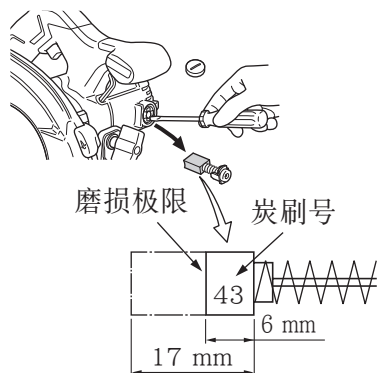
如果需要更换电源线，则必须由此代理的生产厂商进行操作，以免发生危险。

中文

6. 调整底座和锯片以保持垂直

底座和锯片之间的角度已被调整为 90 度，但是，这一垂直角度可能会由于某些原因而改变，请按以下方式调整：

- (1) 将底座转向上方（图 16）并拧松蝶形螺栓（第 10 页的图 5, 6）。
- (2) 将一把直角尺放在底座和锯片上，用六角条形扳手转动六角套筒固定螺丝，移动底座的位置以形成所需的正确角度



图 16

7. 电动机的维护

电动机绕线此电动工具的重要部件。应避免损伤，注意不要被油液或水沾湿。

使用 50 小时后，请用空气枪或其他工具向电动机外壳通风口内吹入干燥的空气，仔细清洁电动机（图 17）。

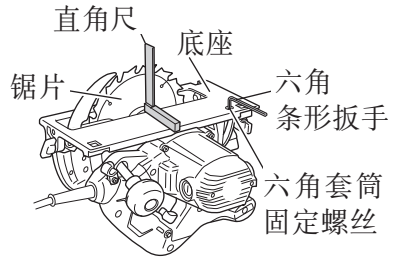
电动机中灰尘或杂质颗粒堆积可能会导致故障。

8. 检查和维护下护罩

确保下护罩能平滑移动。

如果发生故障，请立即修理下护罩。

清洁和维护下护罩时，请使用空气枪或其他工具吹送干燥的空气，吹净下护罩与齿轮罩之间的部位，以及下护罩的转动部位（图 17）。

可以有效去除碎屑或其他杂质颗粒。

下护罩周围堆积碎屑或其他杂质颗粒，可能会导致故障或损伤。

确保下护罩
能平滑移动

下护罩的
转动部位



图 17

警告！

如要防止灰尘吸入或眼睛刺痛，请在使用空气枪或其他工具清洁下护罩、通风孔或产品的其他部分时，仔细佩戴好护目镜和防尘口罩。

注意！

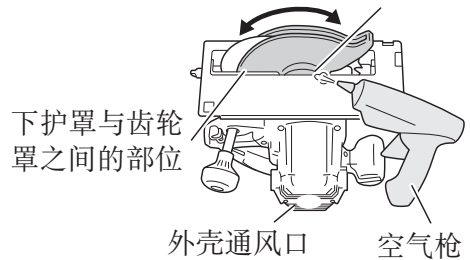
在操作和维修电动工具时，必须遵守贵国制定的安全的有关规则和标准。

附加信息

生产月份和年份的数据见机器和包装的铭牌，以数字和字母编码的月份：1-9 是 1-9 月，O 是 10 月，N 是 11 月，D 是 12 月，生产年份按当年度最后一位数字编码。

选择附件

根据特定作业选择适合的附件。
有关详细信息请联系HiKOKI授权服务中心。



产品编号：370270



产品编号：330888
锯片



产品编号：370279



产品编号：324662

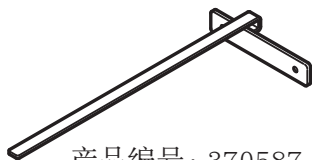

产品编号：370587
引导器



产品编号：872422
六角条形扳手

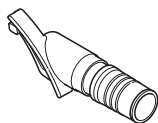

产品编号：997247
集尘器装置



产品编号：370264
杆（短型）

CONTENTS

GENERAL POWER TOOL SAFETY WARNINGS	16
SAFETY INSTRUCTIONS FOR ALL SAWS	19
FURTHER SAFETY INSTRUCTIONS FOR ALL SAWS	19
SAFETY INSTRUCTIONS FOR SAWS WITH INNER PENDULUM GUARD	20
ADDITIONAL SAFETY INSTRUCTIONS FOR ALL SAWS WITH RIVING KNIFE	21
PRECAUTIONS ON USING CIRCULAR SAW	21
SYMBOL.....	22
SPECIFICATIONS.....	22
STANDARD ACCESSORIES	22
APPLICATIONS.....	23
PRIOR TO OPERATION.....	23
ADJUSTING THE SAW PRIOR TO USE	24
CUTTING PROCEDURES.....	26
MOUNTING AND DISMOUNTING THE SAW BLADE	27
USING THE CORD HOLDER	27
MAINTENANCE AND INSPECTION	28
ADDITIONAL INFORMATION	29
SELECTING ACCESSORIES.....	30

GENERAL POWER TOOL SAFETY WARNINGS

WARNING

Read all safety warnings, instructions, illustrations and specifications provided with this power tool.

Failure to follow all instructions listed below may result in electric shock, fire and/or serious injury.

Save all warnings and instructions for future reference.

The term “power tool” in the warnings refers to your mains-operated (corded) power tool or battery-operated (cordless) power tool.

- 1) **Work area safety**
 - a) **Keep work area clean and well lit.**
Cluttered or dark areas invite accidents.
 - b) **Do not operate power tools in explosive atmospheres, such as in the presence of flammable liquids, gases or dust.**
Power tools create sparks which may ignite the dust or fumes.
 - c) **Keep children and bystanders away while operating a power tool.**
Distractions can cause you to lose control.

2) **Electrical safety**

- a) **Power tool plugs must match the outlet.**
Never modify the plug in any way.
Do not use any adapter plugs with earthed (grounded) power tools.
Unmodified plugs and matching outlets will reduce risk of electric shock.
- b) **Avoid body contact with earthed or grounded surfaces, such as pipes, radiators, ranges and refrigerators.**
There is an increased risk of electric shock if your body is earthed or grounded.
- c) **Do not expose power tools to rain or wet conditions.**
Water entering a power tool will increase the risk of electric shock.
- d) **Do not abuse the cord. Never use the cord for carrying, pulling or unplugging the power tool.**
Keep cord away from heat, oil, sharp edges or moving parts.
Damaged or entangled cords increase the risk of electric shock.
- e) **When operating a power tool outdoors, use an extension cord suitable for outdoor use.**
Use of a cord suitable for outdoor use reduces the risk of electric shock.
- f) **If operating a power tool in a damp location is unavoidable, use a residual current device (RCD) protected supply.**
Use of an RCD reduces the risk of electric shock.

3) **Personal safety**

- a) **Stay alert, watch what you are doing and use common sense when operating a power tool.**
Do not use a power tool while you are tired or under the influence of drugs, alcohol or medication.
A moment of inattention while operating power tools may result in serious personal injury.
- b) **Use personal protective equipment. Always wear eye protection.**
Protective equipment such as a dust mask, non-skid safety shoes, hard hat or hearing protection used for appropriate conditions will reduce personal injuries.
- c) **Prevent unintentional starting. Ensure the switch is in the off position before connecting to power source and/or battery pack, picking up or carrying the tool.**
Carrying power tools with your finger on the switch or energising power tools that have the switch on invites accidents.
- d) **Remove any adjusting key or wrench before turning the power tool on.**
A wrench or a key left attached to a rotating part of the power tool may result in personal injury.
- e) **Do not overreach. Keep proper footing and balance at all times.**
This enables better control of the power tool in unexpected situations.
- f) **Dress properly. Do not wear loose clothing or jewellery. Keep your hair and clothing away from moving parts.**
Loose clothes, jewellery or long hair can be caught in moving parts.
- g) **If devices are provided for the connection of dust extraction and collection facilities, ensure these are connected and properly used.**
Use of dust collection can reduce dust-related hazards.

English

- h) **Do not let familiarity gained from frequent use of tools allow you to become complacent and ignore tool safety principles.**

A careless action can cause severe injury within a fraction of a second.

4) Power tool use and care

- a) **Do not force the power tool. Use the correct power tool for your application.**

The correct power tool will do the job better and safer at the rate for which it was designed.

- b) **Do not use the power tool if the switch does not turn it on and off.**

Any power tool that cannot be controlled with the switch is dangerous and must be repaired.

- c) **Disconnect the plug from the power source and/or remove the battery pack, if detachable, from the power tool before making any adjustments, changing accessories, or storing power tools.**

Such preventive safety measures reduce the risk of starting the power tool accidentally.

- d) **Store idle power tools out of the reach of children and do not allow persons unfamiliar with the power tool or these instructions to operate the power tool.**

Power tools are dangerous in the hands of untrained users.

- e) **Maintain power tools and accessories. Check for misalignment or binding of moving parts, breakage of parts and any other condition that may affect the power tool's operation.**

If damaged, have the power tool repaired before use.

Many accidents are caused by poorly maintained power tools.

- f) **Keep cutting tools sharp and clean.**

Properly maintained cutting tools with sharp cutting edges are less likely to bind and are easier to control.

- g) **Use the power tool, accessories and tool bits etc. in accordance with these instructions, taking into account the working conditions and the work to be performed.**

Use of the power tool for operations different from those intended could result in a hazardous situation.

- h) **Keep handles and grasping surfaces dry, clean and free from oil and grease.**

Slippery handles and grasping surfaces do not allow for safe handling and control of the tool in unexpected situations.

5) Service

- a) **Have your power tool serviced by a qualified repair person using only identical replacement parts.**

This will ensure that the safety of the power tool is maintained.

CAUTION

Keep children and infirm persons away.

When not in use, tools should be stored out of reach of children and infirm persons.

SAFETY INSTRUCTIONS FOR ALL SAWS

DANGER

- a) **Keep hands away from cutting area and the blade. Keep your second hand on auxiliary handle, or motor housing.**
If both hands are holding the saw, they cannot be cut by the blade.
- b) **Do not reach underneath the workpiece.**
The guard cannot protect you from the blade below the workpiece.
- c) **Adjust the cutting depth to the thickness of the workpiece.**
Less than a full tooth of the blade teeth should be visible below the workpiece.
- d) **Never hold the workpiece in your hands or across your leg while cutting. Secure the workpiece to a stable platform.**
It is important to support the work properly to minimize body exposure, blade binding, or loss of control.
- e) **Hold power tool by insulated gripping surfaces, when performing an operation where the cutting tool may contact hidden wiring or its own cord.**
Contact with a "live" wire will also make exposed metal parts of the power tool "live" and shock the operator.
- f) **When ripping always use a rip fence or straight edge guide.**
This improves the accuracy of cut and reduces the chance of blade binding.
- g) **Always use blades with correct size and shape (diamond versus round) of arbour holes.**
Blades that do not match the mounting hardware of the saw will run off-centre, causing loss of control.
- h) **Never use damaged or incorrect blade washers or bolt.**
The blade washers and bolt were specially designed for your saw, for optimum performance and safety of operation.

FURTHER SAFETY INSTRUCTIONS FOR ALL SAWS

Causes and operator prevention of kickback:

- kickback is a sudden reaction to a pinched, jammed or misaligned saw blade, causing an uncontrolled saw to lift up and out of the workpiece toward the operator;
- when the blade is pinched or jammed tightly by the kerf closing down, the blade stalls and the motor reaction drives the unit rapidly back toward the operator;
- if the blade becomes twisted or misaligned in the cut, the teeth at the back edge of the blade can dig into the top surface of the wood causing the blade to climb out of the kerf and jump back toward the operator.

Kickback is the result of saw misuse and/or incorrect operating procedures or conditions and can be avoided by taking proper precautions as given below.

- a) **Maintain a firm grip with both hands on the saw and position your arms to resist kickback forces.**
Position your body either side of the blade, but not in line with the blade.

English

Kickback could cause the saw to jump backwards, but kickback forces can be controlled by the operator, if proper precautions are taken.

- b) **When blade is binding, or when interrupting a cut for any reason, release the trigger and hold the saw motionless in the material until the blade comes to a complete stop.**
Never attempt to remove the saw from the work or pull the saw backward while the blade is in motion or kickback may occur.
Investigate and take corrective actions to eliminate the cause of blade binding.
- c) **When restarting a saw in the workpiece, centre the saw blade in the kerf so that the saw teeth are not engaged into the material.**
If saw blade binds, it may walk up or kickback from the workpiece as the saw is restarted.
- d) **Support large panels to minimize the risk of blade pinching and kickback.**
*Large panels tend to sag under their own weight.
Supports must be placed under the panel on both sides, near the line of cut and near the edge of the panel.*
- e) **Do not use dull or damaged blades.**
Unsharpened or improperly set blades produce narrow kerf causing excessive friction, blade binding and kickback.
- f) **Blade depth and bevel adjusting locking levers must be tight and secure before making the cut.**
If blade adjustment shifts while cutting, it may cause binding and kickback.
- g) **Use extra caution when making a “plunge cut” into existing walls or other blind areas.**
The protruding blade may cut objects that can cause kickback.

SAFETY INSTRUCTIONS FOR SAWS WITH INNER PENDULUM GUARD

- a) **Check the lower guard for proper closing before each use. Do not operate the saw if the lower guard does not move freely and close instantly. Never clamp or tie the lower guard into the open position.**
*If the saw is accidentally dropped, the lower guard may be bent.
Raise the lower guard with the retracting handle and make sure it moves freely and does not touch the blade or any other part, in all angles and depth of cut.*
- b) **Check the operation of the lower guard spring. If the guard and the spring are not operating properly, they must be serviced before use.**
Lower guard may operate sluggishly due to damaged parts, gummy deposits, or build-up of debris.
- c) **The lower guard may be retracted manually only for special cuts such as “plunge cuts” and “compound cuts”. Raise the lower guard by the retracting handle and as soon as the blade enters the material, the lower guard must be released.**
For all other sawing, the lower guard should operate automatically.

- d) **Always observe that the lower guard is covering the blade before placing the saw down on bench or floor.**

An unprotected, coasting blade will cause the saw to walk backwards, cutting whatever is in its path.

Be aware of the time it takes for the blade to stop after switch is released.

ADDITIONAL SAFETY INSTRUCTIONS FOR ALL SAWS WITH RIVING KNIFE

- a) **Use the appropriate riving knife for the blade being used.**
For the riving knife to work, it must be thicker than the body of the blade but thinner than the tooth set of the blade.
- b) **Adjust the riving knife as described in this instruction manual.**
Incorrect spacing, positioning and alignment can make the riving knife ineffective in preventing kickback.
- c) **Always use the riving knife except when plunge cutting.**
The riving knife must be replaced after plunge cutting. The riving knife causes interference during plunge cutting and can create kickback.
- d) **For the riving knife to work, it must be engaged in the workpiece.**
The riving knife is ineffective in preventing kickback during short cuts.
- e) **Do not operate the saw if the riving knife is bent.**
Even a light interference can slow the closing rate of a guard.

PRECAUTIONS ON USING CIRCULAR SAW

1. Do not use saw blades which are deformed or cracked.
2. Do not use saw blades made of high speed steel.
3. Do not use saw blades which do not comply with the characteristics specified in these instructions.
4. Do not stop the saw blades by lateral pressure on the disc.
5. Always keep the saw blades sharp.
6. Ensure that the lower guard moves smoothly and freely.
7. Never use the circular saw with its lower guard fixed in the open position.
8. Ensure that the retraction mechanism of the guard system operates correctly.
9. The saw blades body must be thinner than the riving knife and the width of cut, or kerf (with teeth set) must be greater than the thickness of the riving knife.
10. Never operate the circular saw with the saw blade turned upward or to the side.
11. Ensure that the material is free of foreign matters such as nails.
12. The riving knife should always be used except when plunging in the middle of the workpiece.
13. For model C7U3, the saw blades should be from 185 mm to 190 mm.
Body thickness: up to 1.5 mm, tip width: at least 1.9 mm
Riving knife thickness: 1.8 mm

English

14. Disconnect the plug from the receptacle before carrying out any adjustment, servicing or maintenance.
15. Do not use the tool with only the blower function. (Fig. 1)
16. Use only blade diameter specified on the machine.
17. Do not use any abrasive wheel.
18. Check that there are no nicks or scratches in the cord.
19. Check the exterior and ensure that there is no damage.
20. Use a chip saw that is for cutting wood.
21. Use a chip saw with a displayed speed that is equal to or higher than the rotation speed displayed on the tool.
22. Always hold handle of the tool firmly.

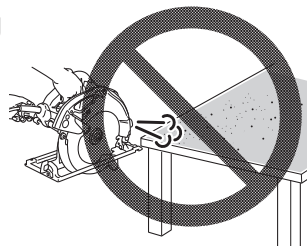

Fig. 1

SYMBOL

WARNING

The following show symbols used for the machine. Be sure that you understand their meaning before use.



To reduce the risk of injury, user must read instruction manual.



SPECIFICATIONS

Voltage		220 V ~
Cutting Depth	90°	0 – 66 mm
	45°	Max. 48 mm
Power Input		1300 W
No-Load Speed		5800 /min
Weight (without cord)		4.7 kg

STANDARD ACCESSORIES

In addition to the main unit (1 unit), the package contains the accessories listed in the below.

Hex. bar wrench		1
Guide		1

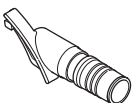
Wing-bolt		1
Lock spring		1
Lever (short type)		1
Dust collector		1

APPLICATIONS

Cutting various types of wood.

PRIOR TO OPERATION

1. Power source
Ensure that the power source to be utilized conforms to the power requirements specified on the product nameplate.
2. Power switch
Ensure that the power switch is in the OFF position. If the plug is connected to a receptacle while the power switch is in the ON position, the power tool will start operating immediately, which could cause a serious accident.
3. Extension cord
When the work area is removed from the power source, use an extension cord of sufficient thickness and rated capacity. The extension cord should be kept as short as practicable.
4. Prepare a wooden workbench (Fig. 2)
Since the saw blade will extend beyond the lower surface of the lumber, place the lumber on a workbench when cutting. If a square block is utilized as a workbench, select level ground to ensure it is properly stabilized. An unstable workbench will result in hazardous operation.

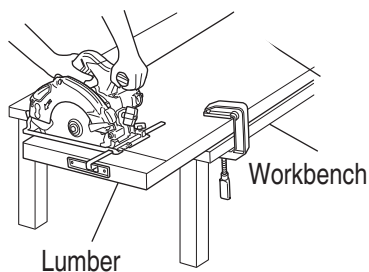

Fig. 2

CAUTION

To avoid possible accident, always ensure that the portion of lumber remaining after cutting is securely anchored or held in position.

ADJUSTING THE SAW PRIOR TO USE

1. Adjusting the cutting depth

As shown in **Fig. 3**, hold the handle with one hand while loosening the knob with the other. The cutting depth can be adjusted by moving the base to the desired position. In such manner adjust the cutting depth and then securely retighten the knob.

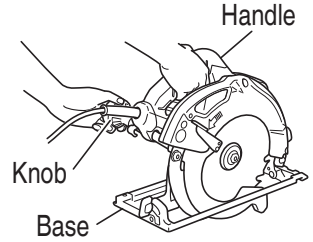

Fig. 3

CAUTION

Should knob remain loosened, it will create a very hazardous situation. Always thoroughly clamp it.

2. Adjusting the riving knife

Set the tool's cutting depth to the minimum. Loosen the hexagonal - socket bolt used to clamp the riving knife, adjust the riving knife so that the distance between the riving knife and the rim of the blade is not more than 3 mm, and the rim of the blade does not extend more than 3 mm beyond the lowest edge of the riving knife (**Fig. 4**) and securely retighten the bolt.

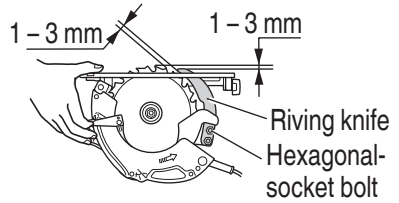

Fig. 4

3. Adjusting the angle of inclination

As shown in **Fig. 5**, **Fig. 6** by loosening the wing-nut on the incline gauge and the wing-bolt on the base, the saw blade may be inclined to a maximum angle of 45° in relation to the base. After having completed the adjustment, reconfirm that the wing-nut and the wing-bolt are firmly tightened.

CAUTION

It is very hazardous to allow wing bolt to remain loosened. Always thoroughly clamp it.

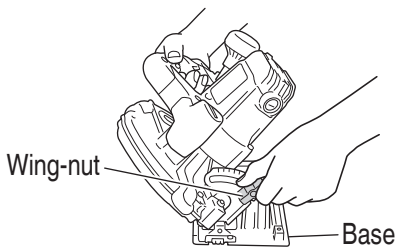

Fig. 5

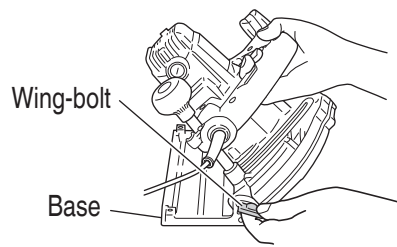

Fig. 6

4. **Regulating the guide (Fig. 7)**
The cutting position can be regulated by moving the guide to the left or right after loosening its wingbolt. The guide may be mounted on either the right or left side of the tool.

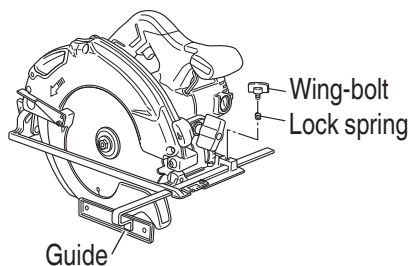

Fig. 7

5. **Adjusting the guide piece**
On the circular saw, it is possible to make fine adjustment of the fixing position of the guide piece, where the saw blade and the premarked line are to be aligned.

When the saw is shipped from the factory, the linear portion of a front scale on the guide piece is aligned with the central position of the saw blade (Fig. 8).

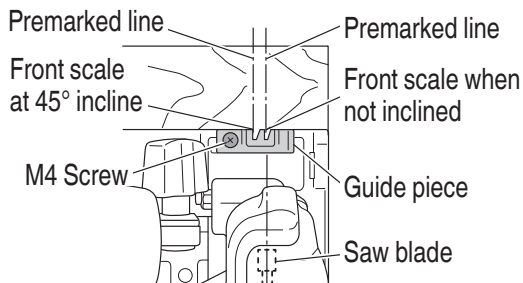

Fig. 8

Loosen the fixed M4 screw on the guide piece, should the fixing position be wrong, and make necessary adjustment of the position.

6. **Using the dust collector**
The dust collector collects sawdust when the vacuum cleaner is attached to the power tool. Remove the lever attached to the power tool and attach lever (short type). Attach the dust collector to the power tool with the M4 screw (Fig. 9).

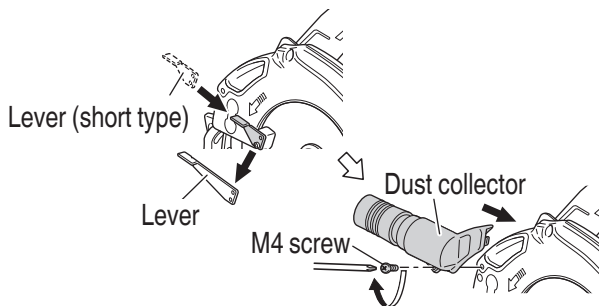

Fig. 9

CUTTING PROCEDURES

1. Place the base on the material, then align the premarked line and the sawblade with the guide piece front scale section at the front of the base (**Fig. 8 on page 25**). When the base is not slanted, use the large cutout as the guide (**Fig. 8 on page 25 and Fig. 10**). If the base is slanted (45 degrees), use the small front scale as the guide (**Fig. 8 on page 25 and Fig. 11**).

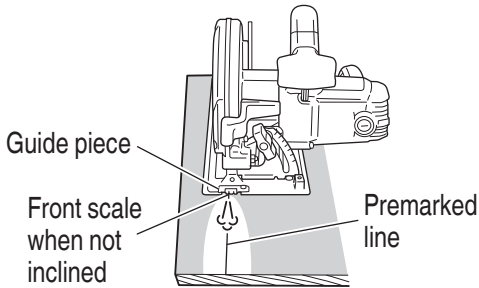

Fig. 10

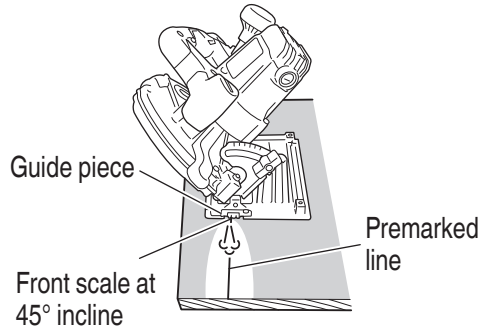

Fig. 11

2. Ensure that the switch is turned to the ON position before the saw blade comes in contact with the lumber. The switch is turned ON when the trigger is squeezed; and OFF when the trigger is released.
3. Moving the saw straight at a constant speed will produce optimum cutting.

CAUTION

Prior to cutting operation, make sure the material you are going to cut. If the material to be cut is expected to generate harmful / toxic dusts, make sure the dust bag or appropriate dust extraction system is connected with dust outlet tightly. Wear the dust mask additionally, if available.

- Before starting to saw, ensure that the saw blade has reached full speed revolution.
- Should the saw blade be stopped or made an abnormal noise during operation, turn off the switch immediately.
- Always take care in preventing the power cord from coming near the revolving saw blade.
- Using the circular saw with the saw blade facing upwards or sideways is very hazardous. Such uncommon applications should be avoided.
- When cutting materials, always wear protective glasses.
- When finished with a job, pull out the plug from the receptacle.

MOUNTING AND DISMOUNTING THE SAW BLADE

CAUTION

To avoid serious accident, ensure the switch is in the OFF position, and the power source is disconnected.

1. Dismounting the saw blade
 - (1) Set the cutting volume at maximum, and place the Circular Saw as shown in **Fig. 12**.
 - (2) Depress the lock lever, lock the spindle, and remove the hexagonal-socket bolt with the Hex. bar wrench.
 - (3) While holding the lower guard lever to keep the lower guard fully retracted into the saw cover, remove the saw blade.
2. Mounting the Saw Blade
 - (1) Thoroughly remove any sawdust which has accumulated on the spindle, bolt and washers.
 - (2) As shown in **Fig. 13**, the side of Washer (A) with a projected center the same diameter as the inner diameter of the saw blade and the concave side of Washer (B) must be fitted to the saw blade sides.
 - (3) To assure proper rotation direction of the saw blade, the arrow direction on the saw blade must coincide with the arrow direction on the saw cover.
 - (4) Using the fingers, tighten the hexagonal-socket bolt retaining the saw blade as much as possible. Then depress the lock lever, lock the spindle, and thoroughly tighten the bolt.

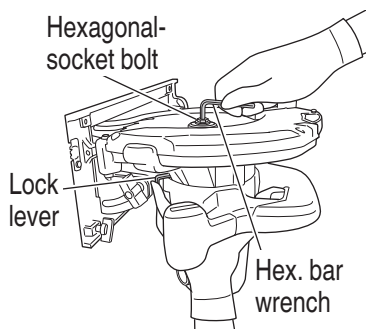

Fig. 12

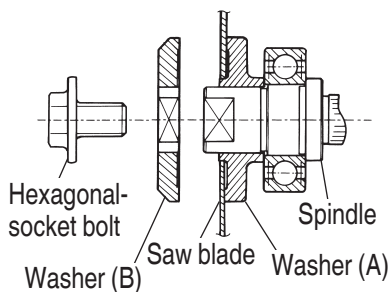

Fig. 13

CAUTION

After having attached the saw blade, reconfirm that the lock lever is firmly secured in the prescribed position.

USING THE CORD HOLDER

Using the cord holder, the cord can be guided toward the rear of the product, as shown in the figure.

If the cord is interfering during operation, hook it into the cord holder and change its angle.

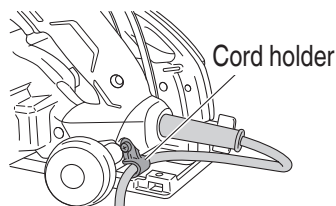

Fig. 14

MAINTENANCE AND INSPECTION

1. Inspecting the saw blade
Since use of a dull saw blade will degrade efficiency and cause possible motor malfunction, sharpen or replace the saw blade as soon as abrasion is noted.
2. Inspecting the mounting screws
Regularly inspect all mounting screws and ensure that they are properly tightened. Should any of the screws be loose, retighten them immediately. Failure to do so could result in serious hazard.
3. Inspecting the carbon brushes (**Fig. 15**)
The motor employs carbon brushes which are consumable parts. Since an excessively worn carbon brush can result in motor trouble, replace the carbon brushes with new ones having the same carbon brush No. shown in the figure when it becomes worn to or near the "wear limit". In addition, always keep carbon brushes clean and ensure that they slide freely within the brush holders.

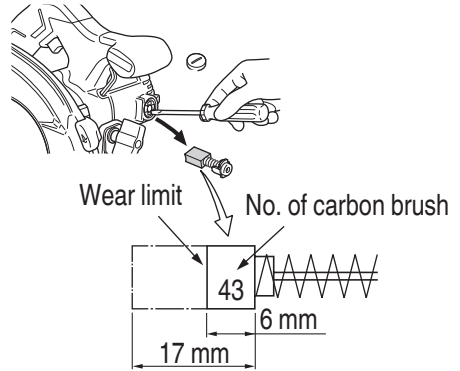

Fig. 15

CAUTION

When replacing the new carbon brushes, always use genuine HiKOKI carbon brushes with the number specified in the drawing.

4. Replacing carbon brushes
Disassemble the brush caps with a slotted-head screwdriver. The carbon brushes can then be easily removed.
5. Replacing supply cord
If the replacement of the supply cord is necessary, this has to be done by the manufacturer of this agent in order to avoid a safety hazard.
6. Adjusting the base and saw blade to maintain perpendicularity
The angle between the base and the saw blade has been adjusted to 90°, however should this perpendicularity be lost for some reason, adjust in the following manner:
 - (1) Turn the base face up (**Fig. 16**) and loosen the wing-nut and wing-bolt (**Fig. 5, 6 on page 24**).
 - (2) Apply a square to the base and the saw blade and turning the hex. socket set screw with a hex. bar wrench, shift the position of the base to produce the desired right angle.

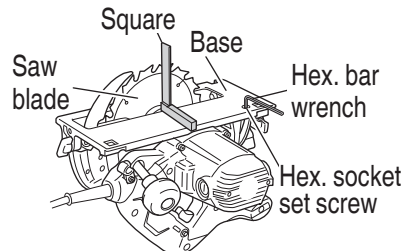

Fig. 16

7. Motor unit maintenance

The motor winding is an important part of this tool. Avoid damaging and be careful to avoid contact with cleaning oil or water.

After 50 hours of use, clean the motor by blowing into the ventilation holes of the motor housing with dry air from an air gun or other tool (**Fig. 17**).

Dust or particle accumulation in the motor can result in damage.

8. Inspecting and maintaining the lower guard

Always make sure that the lower guard moves smoothly.

In the event of any malfunction, immediately repair the lower guard.

For cleaning and maintenance, use an air gun or other tool to blow clean the space between the lower guard and gear cover as well as the rotation part of the lower guard with dry air (**Fig. 17**).

Doing so is effective for the emission of chips or other particles.

Accumulation of chips or other particles around the lower guard may result in malfunction or damage.

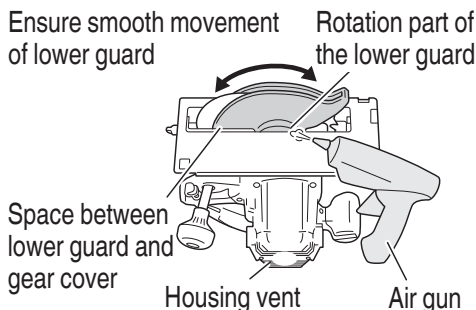

Fig. 17

WARNING

To prevent dust inhalation or eye irritation, wear protective safety goggles and a dust mask when using an air gun or other tool to clean the lower guard, ventilation holes or other parts of the product.

CAUTION

In the operation and maintenance of power tools, the safety regulations and standards prescribed in each country must be observed.

ADDITIONAL INFORMATION

Data about month and year of production see at name plate of machine and package. Months coded by digits and letters: 1-9 – Jan-Sept, O-Oct, N-Nov, D-Dec. Year of production coded by last digit of current year.

SELECTING ACCESSORIES

Select accessories that are suited to a specific task.
For details contact HiKOKI Authorized Service Center.



Part Number: 370270

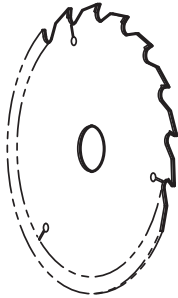

Part Number: 330888
Saw blade



Part Number: 370279



Part Number: 324662

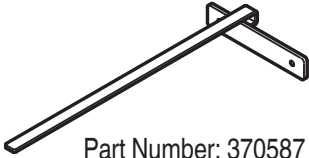

Part Number: 370587
Guide



Part Number: 872422
Hex.bar wrench

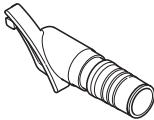

Part Number: 997247
Dust collector

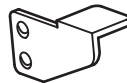

Part Number: 370264
Lever (short type)

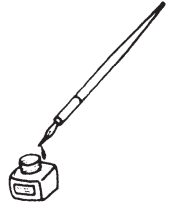

服务中心
高壹工机商业(上海)有限公司
上海市闵行区浦江工业园区三鲁路3585号7幢3楼

制造商
福建高壹工机有限公司
福建省福州市福兴投资区湖塘路

Koki Holdings Co., Ltd.

110
编号: C99718324 F
发行日期: 2021年 10月
中国印刷