

HIKOKI

中文

English

充电式吸尘器
Cordless Cleaner

R 18DC · R 18DTC

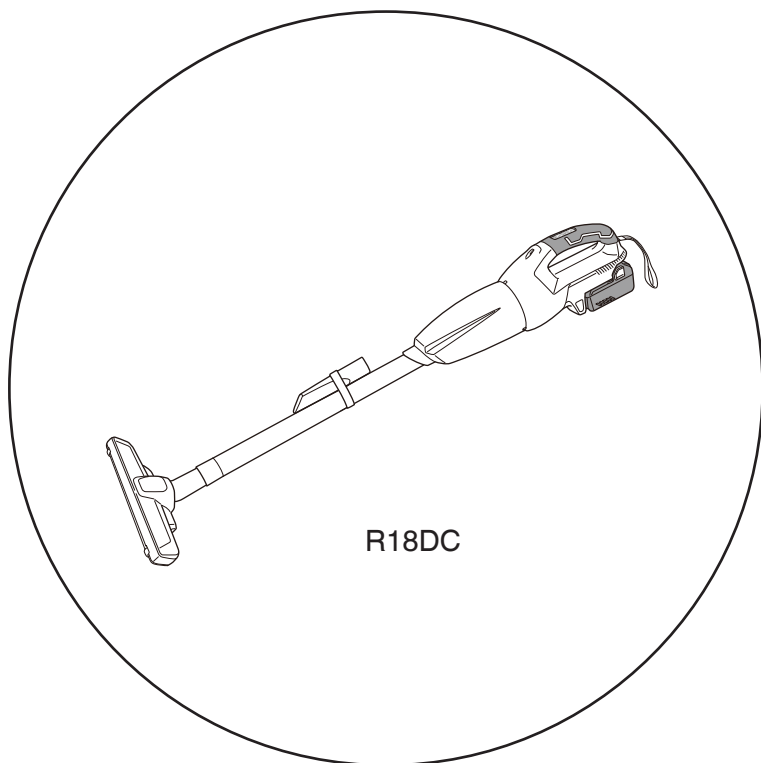

保留备用
Keep for future reference



使用说明书
Handling instructions

目次

充电式吸尘器通用安全警告.....	2
充电式吸尘器的使用注意事项.....	4
其他安全警告.....	5
锂离子电池使用注意事项.....	5
锂离子电池运输.....	7
USB设备连接器使用注意事项.....	7
符号.....	8
零件名称.....	8
规格.....	9
标准附件.....	10
用途.....	10
电池的拆卸 / 安装法.....	11
充电.....	11
作业之前.....	14
开关面板 (R18DC).....	17
使用方法.....	19
清空集尘盒.....	22
USB设备的充电方法(UC18YSL3).....	24
维护和检查.....	26
故障排除.....	29
选择附件.....	31

充电式吸尘器通用安全警告

警告！

阅读所有警告和所有说明。

不遵照以下警告和说明会导致电击、着火和 / 或严重伤害。

保存所有警告和说明书以备查阅。

1) 工作场地的安全

a) 保持工作场地明亮。

黑暗的场地会引发事故。

b) 不要在易爆环境，如有易燃液体、气体或粉尘的环境下操作电器。

电器产生的火花会点燃粉尘或气体。

c) 让儿童和旁观者离开后操作电器。

注意力不集中会使操作者失去对工具的控制。

2) 电气安全

- a) 充电器插头必须与插座相配。绝不能以任何方式改装插头。
未经改装的插头和相配的插座将减少电击危险。
- b) 不得将电器暴露在雨中或潮湿环境中。
水进入电器将增加电击危险。
- c) 不得滥用充电器的电线。绝不能用电线搬运、拉动充电器或拔出其插头。
使电线远离热源、油、锐边或运动部件。
受损或缠绕的软线会增加电击危险。

3) 人身安全

- a) 保持警觉，当操作电器时关注所从事的操作并保持清醒。
当你感到疲倦，或在有药物、酒精或治疗反应时，不要操作电器。
在操作电器时瞬间的疏忽会导致严重人身伤害。
- b) 手不要伸展得太长。时刻注意立足点和身体平衡。
这样在意外情况下能很好地控制电器。

4) 吸尘器使用和注意事项

- a) 不要滥用电器。根据用途使用适当的电器。
选用适当设计的电器会使你工作更有效、更安全。
- b) 如果开关不能接通或关断电器电源，则不能使用该电器。
不能用开关来控制的电器是危险的且必须进行修理。
- c) 在进行任何调节、更换附件或贮存电器之前，必须将电池盒与电器脱开。
这种防护性措施将减少电器意外起动的危险。
- d) 将闲置不用的电器贮存在儿童所及范围之外，并且不要让不熟悉电器或对这些说明不了解的人操作电器。
电器在未经培训的用户手中是危险的。
- e) 保养电器。检查运动件是否调整到位或卡住，检查零件破损情况和影响电器运行的其他状况。
如有损坏，电器应在使用前修理好。
许多事故由维护不良的电器引发。
- f) 按照使用说明书，考虑作业条件和进行的作业来使用电器和附件等。
将电器用于那些与其用途不符的操作可能会导致危险。

5) 电池盒的使用和注意事项

此电器仅可使用附带的或本公司规定的锂电池来供电。

- a) 只用制造商规定的充电器充电。
将适用于某种电池盒的充电器用到其他电池盒时会发生着火危险。
- b) 只使用配有特制电池盒的电器。
使用其他电池盒会发生损坏和着火危险。

- c) 当电池盒不用时，将它远离其他金属物体，例如回形针、硬币、钥匙、钉子、螺钉或其他小金属物体，以防一端与另一端连接。电池端部短路会引起燃烧或火灾。
- d) 在滥用条件下，液体会从电池中溅出；避免接触。如果无意间碰到了，用水冲洗。如果液体碰到了眼睛，还要寻求医疗帮助。从电池中溅出的液体会发生腐蚀或燃烧。

6) 维修

- a) 将你的电器送交专业维修人员，使用同样的备件进行修理。这样将确保所维修的电器的安全性。

注意！

不可让儿童和体弱人士靠近工作场所。

应将不使用的电器存放在儿童和体弱人士接触不到的地方。

充电式吸尘器的使用注意事项

1. 请勿吸下列物品：否则可能会造成起火或受伤。
 - 液体（如水、油）或潮湿的碎片。
 - 研磨或切割金属时产生的火花。
 - 点燃的香烟等高温物品。
 - 易燃物质(汽油、稀释剂、苯、煤油、油漆等)、爆炸性物质(甘油三硝酸酯等)、可燃物质(铝、锌、镁、钛、红磷、黄磷、赛璐珞等)。
 - 尖锐物体，如指甲、剃刀或玻璃。
 - 水泥粉和调色剂等固体物质以及金属粉末和碳粉等传导性细粉尘。
2. 使用前请正确装入过滤器。请勿在未装上过滤器或装在错误位置上的情况下使用本产品，也勿使用撕裂的过滤器。否则可能会造成马达烧坏等问题。
3. 本电器仅适用于室内。切勿将其用于室外。请勿在雨中使用。请远离水或油。
否则可能导致故障，因为本电器不防水。
4. 请勿在吸入口或排气口被堵住的情况下使用本电器。
否则马达温度可能会异常升高，造成零件变形或马达烧坏等问题。
5. 请勿在吸入口被堵住的情况下操作本电器。
否则马达可能会烧坏，造成零件变形或马达故障。
6. 当不小心把本电器掉在地上或碰撞本电器后，请检查本电器是否损坏、破裂或变形。损坏、破裂或变形可能会造成受伤。
7. 如果在使用本电器时出现异常或发出异常声音，请立即关闭开关并让当地零售商或授权维修代理商修理。如果在未修理的情况下继续使用，可能会造成受伤。

其他安全警告

1. 务请在 0°C — 40°C 的温度下进行充电。
温度低于 0°C 将会导致充电过度，极其危险。电池不能在高于 40°C 的温度下充电。
最适合于充电的温度是 20°C — 25°C 。
2. 不要连续使用充电器。
一次充电完毕后，在15分钟内不要再次使用该充电器对电池充电。
3. 勿让杂质进入可充电电池的连接口内。
4. 切勿拆卸可充电电池或充电器。
5. 切勿使充电式电池短路。电池短路会引起强电流和过热。从而烧坏电池。
6. 请勿将电池丢入火中。
电池受热将会爆炸。
7. 充电后电池寿命太短不够使用时，请尽快将电池送往经销店。请勿将用过的电池乱丢。
8. 请勿将异物插入充电器的通风口。
若将金属异物或易燃物插入通风口的话，将会引起触电事故或使充电器受损。
9. 长时间连续使用本电钻，可能会导致机体过热，对马达及开关造成损害。因此，机壳变热时，请让工具休息一段时间。
10. 确认已紧紧装上电池。如果松弛则电池可能会脱开，并造成事故。
11. 请勿使用工具或电池端子（电池安装部位）明显变形的产品。
否则，安装电池后可能会短路，造成冒烟或起火。
12. 请清除工具端子（电池安装部位）上的削屑和灰尘。
 - 使用前请确保电池上没有堆积削屑和灰尘。
 - 在使用过程中，请尽量避免工具上的削屑或灰尘掉落在电池上。
 - 暂时不使用工具时或使用后，应将工具存放在不会掉落削屑或灰尘的地方。
否则可能短路，造成冒烟或起火。
13. 请在 -5°C — 40°C 环境下使用本工具及电池。

锂离子电池使用注意事项

为延长使用期限，锂离子电池配备停止输出的保护功能。在下述的1至3情况下，在使用本产品时，即使其已开启，电机仍可能停止。这并非故障，而是启动保护功能的结果。

1. 在残留的电池电力即将耗尽时，马达会停止。
在这种情况下，请立即予以充电。
2. 若工具超过负荷，马达亦可能停止。在此情况下，将工具关闭并消除过载的可能原因。之后您就可以再度使用。

中文

3. 若电池在过载工作情况下过热，电池电力可能会中止。

在这种情况下，请停止使用电池，让电池冷却。之后您就可以再度使用。此外，请留心下列的警告及注意事项。

警告！

为防止发生电池漏电、发热、冒烟、爆炸及提前点燃，请确保留意下列事项。

1. 确保电池上没有堆积削屑及灰尘。
 - 在工作时确定削屑及灰尘没有掉落在电池上。
 - 确定所有工作时掉落在电器上的削屑和灰尘没有堆积在电池上。
 - 请勿将未使用的电池存放在曝露于削屑和灰尘的位置。
 - 在存放电池之前，请清除任何可能附着在上面的削屑和灰尘，并请切勿将它与金属零件（螺丝、钉子等）存放在一起。
2. 请勿以钉子等利器刺穿电池、以铁锤敲打、踩踏、丢掷电池，或将其剧烈撞击。
3. 切勿使用明显损坏或变形的电池。
4. 请依规定方式使用电池，切勿移作他用。
5. 如果已过了再充电时间，电池仍无法完成充电，请立即停止继续再充电。
6. 请勿将电池放置于高温或高压处，例如微波炉、烘干机或高压容器内。
7. 在发觉有渗漏或异味时，请勿接近远离火源。
8. 请勿在会产生强烈静电的地方使用。
9. 如有电池渗漏、异味、发热、褪色或变形，或在使用、充电或存放时出现任何异常，请立即将它从装备或电池充电器拆下，并停止使用。
10. 请勿浸泡电池或让任何液体流入电池内部。导电液体进入（如水），可能造成电池损坏，甚至可导致火灾或爆炸。将电池存放在阴凉、干燥的地方，远离易燃物品。必须避免将电池置于腐蚀性气体环境中。

注意！

1. 若电池渗漏出的液体进入您的眼睛，请勿搓揉眼睛，并以自来水等干净清水充分冲洗，立刻送医。
若不加以处理，液体可能会导致眼睛不适。
2. 若液体渗漏至您的皮肤或衣物，请立即以自来水等清水冲洗。
上述情况可能会使皮肤受到刺激。
3. 若初次使用电池时发现生锈、异味、过热、褪色、变形及 / 或其它异常情况时，请勿使用并将该电池退还给供货商或厂商。

警告！

如果导电异物接触到锂离子电池的端子，电池可能短路，并导致火灾。存放锂离子电池时，请务必遵循下列注意事项。

- 切勿在存放盒中放置导电的残片，钉子，以及导线，如铁线和铜线。

- 或者将电池装在电器中，或者在牢固按入电池盖并挡住通风孔后再存放，以防止短路。(参照图1)



图1

锂离子电池运输

当运输一个锂离子电池，请注意以下预防措施。

警告！

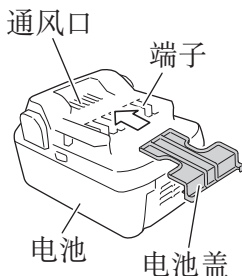
告知运输公司，包装内包含一个锂离子电池，告知该公司其功率输出并且要按照运输公司的指引安排运输。

- 功率输出超过100Wh的锂离子电池被视作危险物品运输分类并且需要特别申请程序。
- 对于境外运输，您必须遵守国际法以及输入国的规章和条例。



图2

USB设备连接器使用注意事项



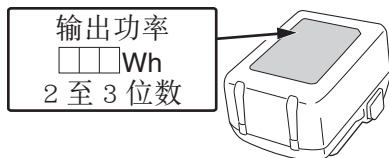

发生意外情况时，本产品连接的USB中保存的数据可能发生损坏或丢失。使用本产品前，请务必备份USB设备中的数据。

请注意，如USB设备中存储的数据发生损坏、丢失或连接的设备发生损坏，本公司概不负责。

符号

警告！

如下所示的符号用于本电器。使用前请务必理解其含意。

	为降低伤害风险，用户必须阅读使用说明书
	直流电
	额定电压
	警告

零件名称

1. 吸尘器



图3

规格

吸尘器

型式		R18DC	R18DTC
电压		18V	
电动机		DC 马达	
连续工作时间 (电池：使用 BSL36A18X时)	3 (高)	约40分钟	约40分钟
	2 (中)	约48分钟	
	1 (低)	约66分钟	
抽吸功率	3 (高)	约 40W	约40W
	2 (中)	约 30W	
	1 (低)	约 16W	
集尘容量		560mL	
本电器可用的电池		多电压电池, BSL18系列	
重量		1.7kg (安装 BSL36A18X)	

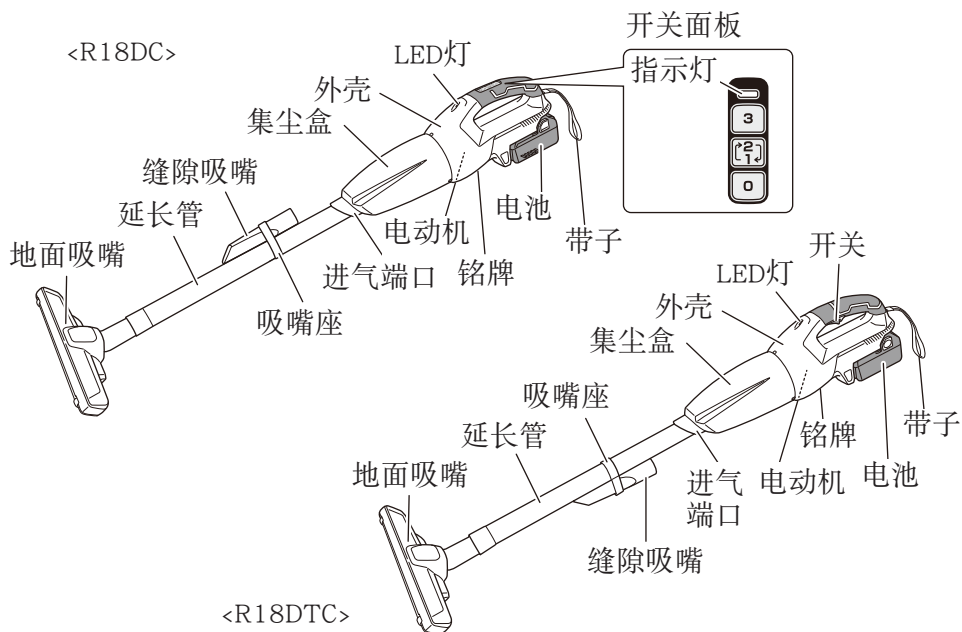
电池（另售）

型式	BSL36A18X
电压	36V / 18V (自动转换*1)
电池容量	2.5Ah / 5.0Ah (自动转换*1)
可用无线产品*2	多伏系列, 18V产品
可用充电器	锂电池滑动充电器

*1 工具自身可自动切换。

*2 详情请见总目录。

中文



充电器（另售）

型式	UC18YSL3
充电电压	14.4－18V
重量	0.6kg

标准附件

除了主机（1 台）外，产品包中还包括表中所列的附件。

表1

		R18DC (NN)	R18DTC (NN)
地面吸嘴		1	1
缝隙吸嘴		1	1
延长管 (包含吸嘴座)	 吸嘴座	1	1

标准附件可能不预先通告而已予更改。

用途

- 干燥表面的轻负荷吸尘

电池的拆卸 / 安装法

1. 电池的拆卸法

请先紧抓住把手、然后再推压电池插销以拆下电池 (参照图4)。



图4

注意！

切勿使电池短路。

2. 电池的安装法

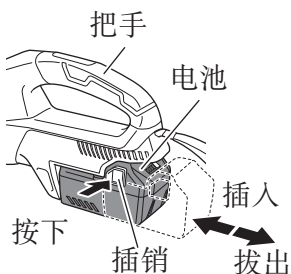
将电池对准本机的凹槽，并用力将电池按入直至听到咔哒声 (参照图4)。

充电

使用电器之前，按下述方法将电池进行充电。

<UC18YSL3>

1. 将充电器的电源线连接到插座。

将充电器插头连接到插座时，充电指示灯闪烁红色。(参照表2)

2. 将电池插入充电器。

如图5所示，将电池紧紧地插入充电器。



图5

中文





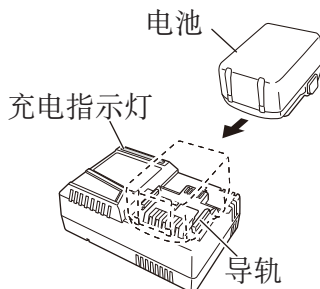

3. 充电

将电池插入充电器后，充电开始，并且充电器指示灯将呈蓝色闪烁。电池完全充电后，充电器上的充电指示灯将点亮呈绿色。(参照表2)

(1) 充电指示灯的指示状态

根据充电器或可充电电池的情况，充电指示灯的显示如表2所示。

表2: 充电指示灯的指示状态

每隔0.5秒开/关一次 (红色) 	充电前*1
每隔1秒点亮0.5秒 (蓝色) 	充电量低于50%
每隔0.5秒点亮1秒 (蓝色) 	充电量低于80%
持续亮起 (蓝色) 	充电量高于80%
持续亮起 (发出持续蜂鸣声: 约6秒) (绿色) 	充电完成
每隔0.3秒开/关一次 (红色) 	过热而等待*2
每隔0.1秒开/关一次 (发出断续蜂鸣声: 约2秒) (紫色) 	无法充电*3

注:

*1 如果连好充电器后指示灯依旧闪烁红色，请检查并确认电池已完全插入。

*2 电池过热。无法充。

虽然继续放置在原处，电池将在冷却后开始充电，但最好是将电池取出并放置在阴凉、通风良好的位置处冷却。

*3 电池或充电器有问题。

– 请紧紧插入电池。

– 并确认电池安装部位或端部无异物堵塞。若无异物，则可能电池或充电器发生故障。请带去经授权的维修中心检查。

- 连续使用时，电池充电器温度将提升，因此会导致出现故障。充电完成后，在下次充电之前，请使其冷却5分钟。

(2) 关于电池的温度和充电时间（参照表3）

表3

型式	UC18YSL3	
电池类型	锂离子电池	
充电电压	14.4-18V	
电池可充电温度	0°C-50°C	
电池容量的大致充电时间（20°C下）	1.5Ah	15 分钟
	2.0Ah	20 分钟
	2.5Ah	25 分钟
	3.0Ah	20 分钟 (BSL1430C、BSL1830C: 30 分钟)
	4.0Ah	26 分钟 (BSL1840M: 40 分钟)
	5.0Ah	32 分钟
	6.0Ah	38 分钟
多伏电池容量的大致充电时间（20°C下）	1.5Ah（×2节）	20 分钟
	2.5Ah（×2节）	32 分钟
	4.0Ah（×2节）	52 分钟
电池数量	4-10	
USB充电电压	5V	
USB充电电流	2A	
重量	0.6kg	

注:

- 充电时间可能会因环境温度和电源电压而异。
○ 充电时间较长

中文

- 环境温度过低时，充电时间会延长。请在温暖的场所中（如室内）给电池充电。
 - 请勿堵塞排气孔。否则会导致内部过热，从而降低充电器的性能。
 - 冷却扇未运转，请联系HiKOKI授权服务中心进行维修。
4. 从电源插座拔下充电器的电源线。
 5. 握紧充电器并取出电池。

注:

充电后，先将电池从充电器中取出，然后妥善保存。

关于新电池的放电。

新电池内部的化学物质未被激活或电池长时间不使用时，初次或第二次使用时需要将其放电至较低电量。这只是暂时现象，将电池充电2-3次即可恢复为充电所需的正常时间。

较长时间保持电池性能的方法

- (1) 在电池电力完全耗尽之前进行充电。
感到电动工具的能力变弱时，请停止使用并给电池充电。若您继续使用电动工具并耗尽电力，电池可能会损坏或其使用寿命缩短。
- (2) 避免在高温环境中充电。
使用后可充电电池的温度将迅速升高。若使用后立即对这种电池进行充电，其内部化学物质会劣化，电池使用寿命将缩短。请稍等片刻，待电池冷却后再进行充电。

作业之前

1. 工作环境的准备和检查
请按下列注意事项检查工作环境是否适当。
2. 安装和拆卸过滤器
使用本产品前，请检查过滤器是否妥善安装。

(1) 取下集尘盒 (图6)

从进气端口观看灰尘盒，将其逆时针旋转约120度，将灰尘盒和外壳上的凸起标记对准，然后将其拉下。



图6

(2) 取下过滤器。(图7)

顺时针旋转过滤器，将其从机壳处取下。

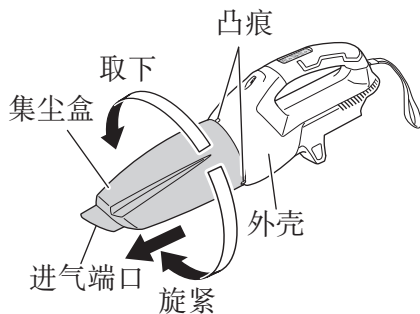

图7

(3) 检查过滤器 (图8)

检查过滤器是否损坏或污染。

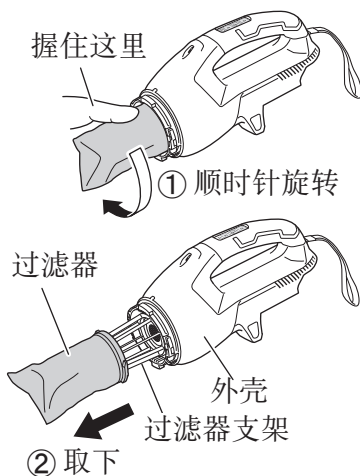

图8

(4) 安装过滤器 (图9)

安装过滤器时，沿水平方向用力按压机壳的突起处。然后旋转过滤器，直到突起处固定在机壳的凹槽中。

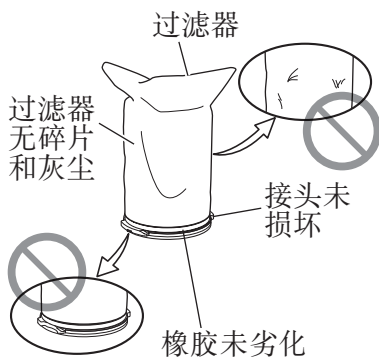

图9

(5) 安装集尘盒 (图10)

将集尘盒安装在机壳上，对准两处凸痕。然后顺时针旋转集尘盒约120度。

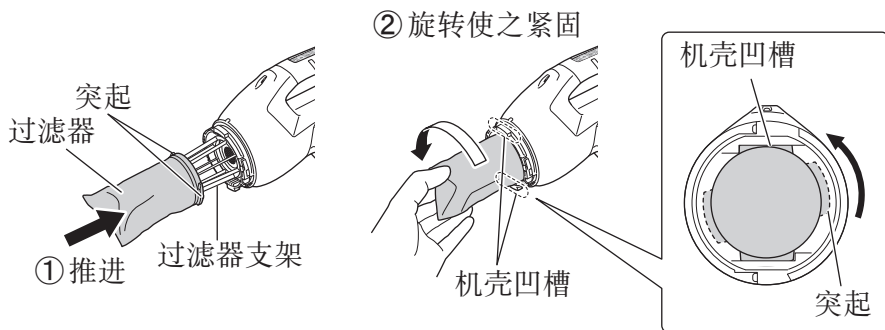

图10

注:

若过滤器安装不当，可能会使灰尘或污垢进入风机，导致发生故障或损坏。

开关面板 (R18DC)

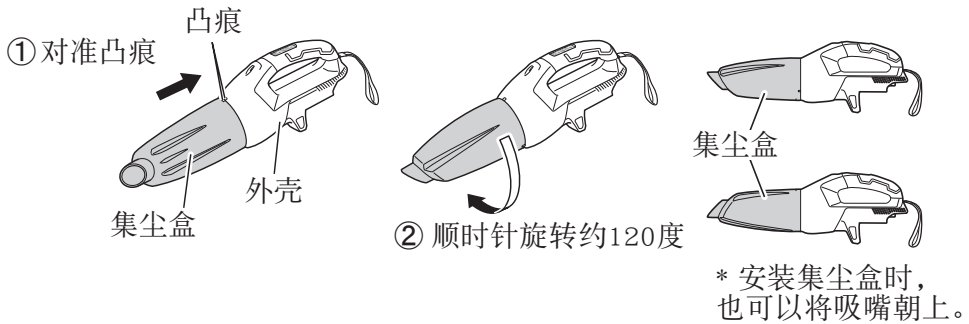
注意！

请勿撞击或损坏开关面板。

1. 开关操作 (图11)

可根据需要，在3档间任选切换吸尘操作。

电源关闭时，按下“3”按钮或“2 / 1”按钮将启动设备。同时，LED灯将开启。按下“2 / 1”按钮，切换中模式和低模式。

使用本产品时，切换到模式“1”可降低噪声。

按“0”按钮，关闭设备。这也将关闭LED灯。



图11

模式	连续工作时间
	BSL36A18X
3 (高)	约40分钟
2 (中)	约48分钟
1 (低)	约66分钟

* 连续工作时间因电池状况而异。请参照表格。

2. 指示灯 (图12)

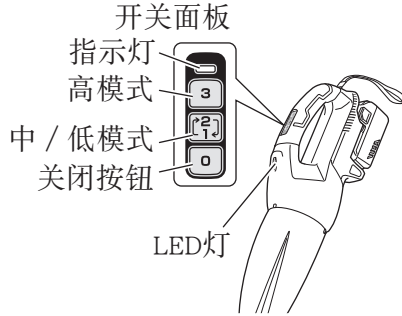
操作过程中, 若电池电量较低, 指示灯将亮起。此时, 请将本产品充电。



图12

使用方法

警告！

装卸充电电池时，为了防止事故，请关闭本电器的开关。

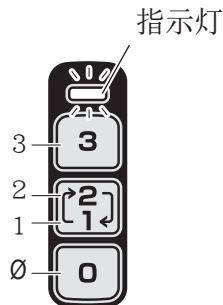
注意！

- 确认已正确装入充电电池。否则电池可能会掉出，造成受伤。
- 确保使用本电器时已安装过滤器。否则可能导致人员受伤或设备故障。

1. 检查过滤器（图13）

检查是否已安装过滤器。同时，检查并确保过滤器未损坏或脏污。（请参阅第16页的“检查过滤器”）



图13

2. 安装吸嘴（图14）

通过操作，将吸嘴插入产品的吸入口。不安装吸嘴也可使用本电器。

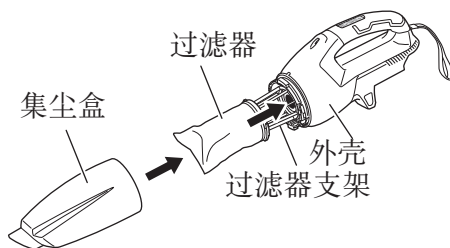

图14

注:

安装吸嘴或延长管时，按照箭头指示的方向插入。（图15）
拆下时，按照箭头指示的方向扭转。
按照相反的方向扭转将导致集尘盒与机壳分离。

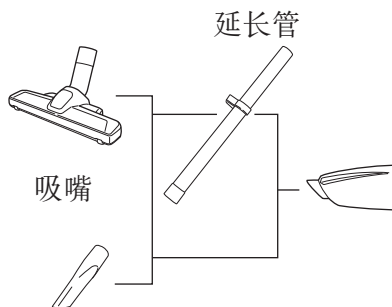

图15

3. 安装电池（图16）

如下图所示，将电池插到底直到听见喀哒声。

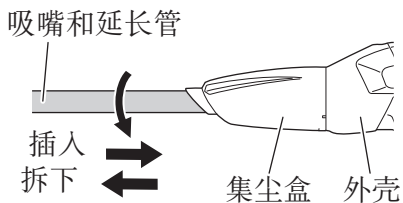

图16

4. 启动本电器

<R18DC>

根据需要按下模式按钮。（图17）

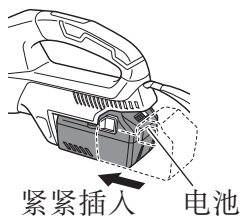
（参照第17页的“开关面板（R18DC）”）



图17

<R18DTC>

拉下开关时，本产品与LED灯接通。松开开关，本产品与LED灯断开。

(图18)

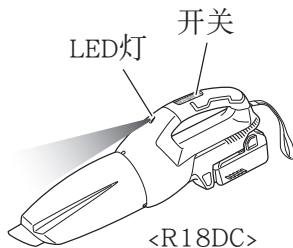

图18

注意！

- 请不要直视灯光，避免眼睛直接受LED灯照射。如果眼睛持续受LED灯照射，会伤害眼睛。
- 用一块软布擦去附着在LED灯镜头上的任何灰尘或污垢，注意不要刮擦镜头。LED灯镜头上的刮擦会导致亮度降低。

5. 剩余电池电量指示灯

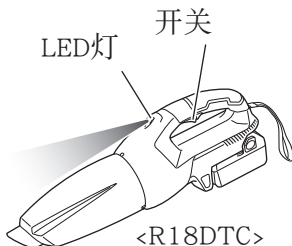
可以按下剩余电池电量指示灯开关点亮指示灯，查看电池的剩余电量。

(图19, 表4)



图19

按住剩余电池电量指示灯开关约3秒后，指示灯将熄灭。





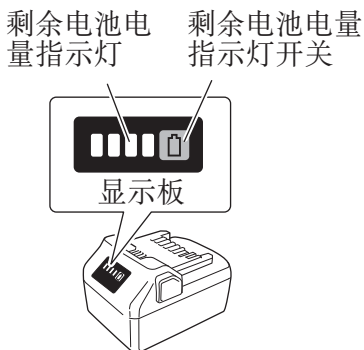

环境温度和电池状态可能会对剩余电池电量产生轻微的影响，因此，建议您仅将指示灯作为参考。

中文

注:

此外，电动工具或充电器上的剩余电池电量指示灯可能有所不同。

表4

	点亮； 电池剩余电量超过75%。
	点亮； 电池剩余电量为50%—75%。
	点亮； 电池剩余电量为25%—50%。
	点亮； 电池剩余电量超过25%。
	闪烁； 电池剩余电量即将耗尽。请尽快对电池进行充电。
	闪烁； 因高温暂停输出。从电动工具中取下电池，让电池完全冷却。
	闪烁； 因失败或故障暂停输出。电池可能出现故障，请与经销商联系。

环境温度和电池特性不同，则所显示的电池剩余电量也会有些许不同，以上内容仅供参考。

注:

请勿强烈撞击或破坏开关面板。否则可能会导致故障。

清空集尘盒

警告！

为了防止事故，请务必关闭电源，并从本电器中取出充电电池。

注意！

○ 请勿让集尘盒受到强烈冲击，否则会造成变形或损坏。

○ 请经常清空集尘盒，并保持本电器和过滤器等的清洁。否则可能会降低吸尘效率或造成马达的故障或发出异味。

1. 旋转集尘盒，将其从机壳取下。（图20）

注:

取下集尘盒时，将吸入口朝下，倒出灰尘。



图20

2. 处理集尘盒中的灰尘。

3. 若处理灰尘后无法重新盖上吸嘴，请清洁过滤器。

4. 将过滤器和集尘盒安装到机壳。

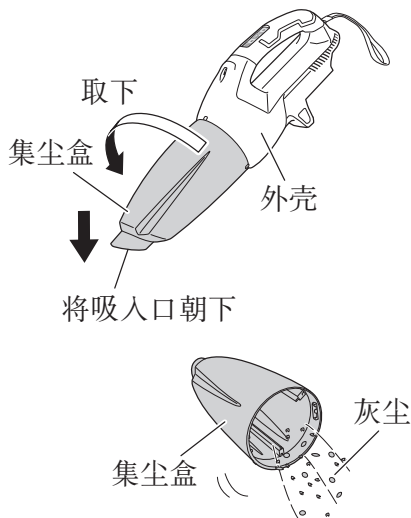
高效清除灰尘（图21）

本产品有清除灰尘的内置结构，可在取下集尘盒时清除粘附到过滤器的灰尘。反复旋转集尘盒（2至3次或以上）可更高效地清除灰尘。

握住电器，使集尘盒不会从外壳上脱落，轻轻地反复朝指定方向转动集尘盒。

将集尘盒前后翻转2或3次



图21

USB设备的充电方法(UC18YSL3)

警告！

- 使用之前请检查USB连接线缆是否有破损或损坏。使用有破损或损坏的USB线缆可能会导致冒烟或着火。
- 不使用产品时，请用橡胶盖封好USB端口。USB端口中落入灰尘等可能会导致冒烟或着火。

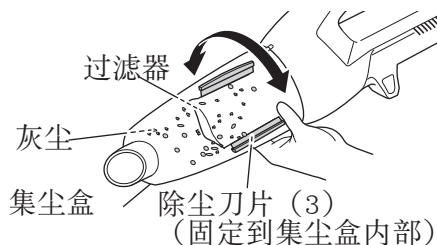
注:

- USB充电期间可能会偶尔暂停。
- USB设备未充电时，从充电器上拆下USB设备。否则不仅会减少USB设备的电池寿命，还会导致意外事故。
- 设备的类型，可能无法对某些USB设备充电。

1. 选择充电方式

根据所选的充电方式，将电池插入充电器或连接电源线插入插座。

- 将USB设备插入插座进行充电。(图22-a)
- 将USB设备和电池插入插座进行充电。(图22-b)



图22

2. 连接USB线缆。(图23)

拔下橡胶盖并将市售的USB线缆（匹配充电的设备）紧紧插入USB端口。

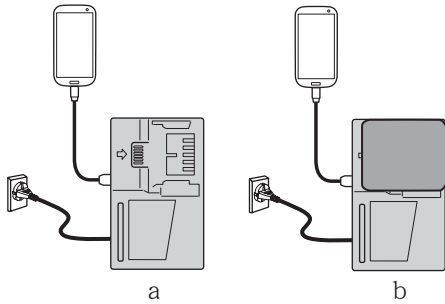

图23

3. 充电完成时

- 检查USB设备以检验充电状态。
- 从插座中拔下电源线。(图24)
- 用橡胶盖盖住USB端口。

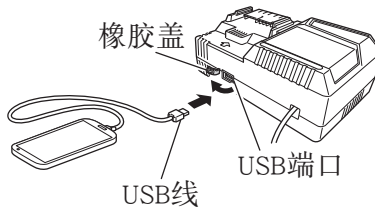

图24

维护和检查

警告！

维护和检查前，请务必关闭开关。

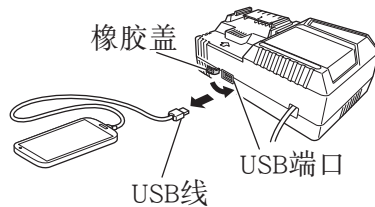
1. 清洁过滤器

如果即使清空集尘盒后吸尘效率也不理想，请取下过滤器，并用冷水或温水清洗。（水温应为不烫手。）

清洗后，在阴凉处晾干。（图25-a）

或可使用气枪或类似工具由内向外吹除附着在过滤器上的任何碎屑。

（图25-b）

注：

- 请勿用洗涤剂清洗过滤器。
- 请勿用热水清洗过滤器或用火将其烘干。
- 请勿使用气枪或类似工具清洁过滤器、风扇过滤器及电器本身。

（图25-c）

否则会使灰尘进入电器内部并导致故障。

晾干水分



图25

2. 清洁风扇过滤器（图26）

如风扇过滤器上沾有灰尘，请拿起吸尘器，使风扇过滤器朝下，以免灰尘进入电机，同时用小刷子（如用过的牙刷）轻轻清洁。

使用牙刷或类似工具清洁（请勿用力刷洗）

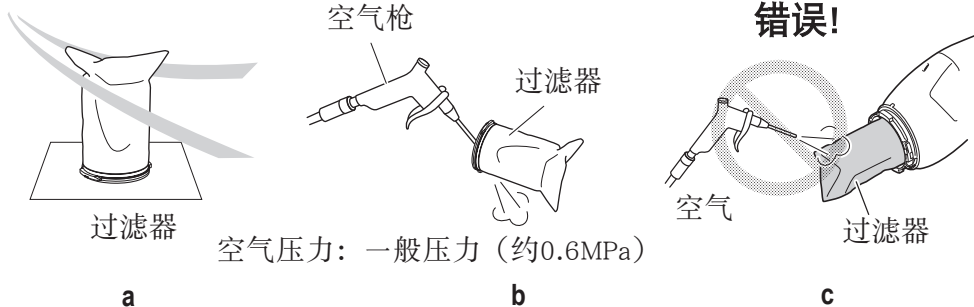

图26

3. 检查地面吸嘴

检查地面吸嘴，确认其刀刃未脱落。如果刀刃脱落，将其压入，直至其卡在突起处。

在刀刃脱落的情况下使用，可能会造成脏污。

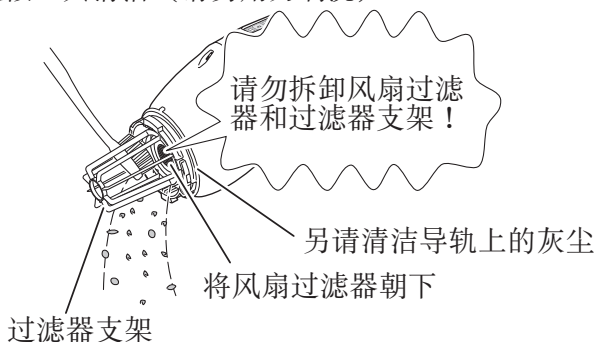
更换刀刃时，从导轨的凹口开始将其插入，并沿凹槽穿入。确保没有垂落。（图27）



图27

4. 检查安装螺钉

要经常检查安装螺钉是否紧固妥善。若发现螺钉松了，应立即重新扭紧，否则会导致严重事故。

5. 电动机的维护

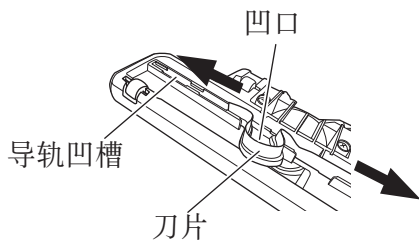
电动机绕线是电动工具的“心脏部”应仔细检查有无损伤，是否被油液或水沾湿。

中文

注:

定期空转电机，以清除污垢和灰尘。
若电机内堆积有污垢或灰尘，可能会导致设备损坏。

6. 检查端子（工具和电池）
确保端子上没有堆积削屑和灰尘。
在操作前、操作时和操作后需要时常检查。

注意！

请清除端子上的削屑或灰尘。否则可能导致故障。

7. 清理外部
在工具脏污时，使用柔软的干布或用肥皂水润湿的布进行擦拭。切勿使用氯溶液、汽油或稀释剂，以免塑胶部分溶化。
8. 收藏
请将充电式吸尘器存放在温度低于 50°C 、儿童无法拿到的地方。
竖立放置本电器时，请将电器的带子挂到挂钩上。

注:

- 请勿将本电器存放在儿童可以轻易触碰或取出的地方。
- 请勿将本电器存放在潮湿或可能被雨淋湿的地方。
- 请勿将本电器存放在阳光直射或温度变化较大的地方。
- 请勿将本电器与易燃易爆的挥发性物质一同存放。
- 若无带子固定，请勿将本电器靠在墙上。
(图28) 否则电器可能会摔落导致损坏。



图28

注:**存放锂离子电池**

在存放前请确保锂离子电池已完全充电。

电池在低电量的状态下长时间存放（3个月或更长），可能会导致电池性能劣化，使用时间明显减少或无法进行充电。

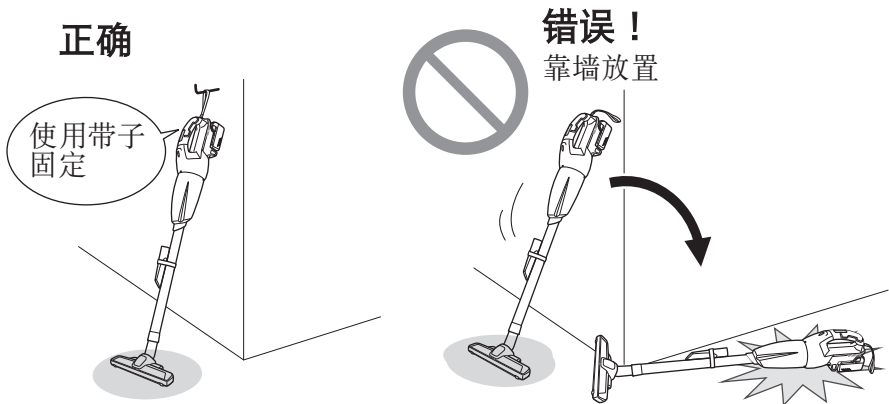
但是，即使是使用时间明显减少的电池，通过反复充电和使用2~5次，有时也可恢复使用时间。

若反复充电和使用后电池的使用时间仍非常短，请认作为电池已达到了使用寿命并更换新的电池。

注意！

在操作和维修电器时，必须遵守贵国制定的安全的有关规则和标准。

关于HiKOKI牌无线电器的重要通知：

请确保始终使用我们指定的正版电池。如果使用我们指定以外的电池，或对电池进行拆卸和改动（例如拆卸和更换电池组件或其他内部部件），那么我们无法保证我们无线电器的安全性和使用性能。

故障排除

如果吸尘器操作不正常，请使用下表中的检查步骤。如果未能解决问题，请向经销商或HiKOKI公司授权服务中心咨询。

现象	可能的原因	解决办法
吸尘器无法运行	没有剩余电池电量	为电池充电。
吸尘器突然停止	风扇被灰尘堵塞引起设备过载。	联系经销商并安排拆卸和清洁作业。
	电池过热。	让电池冷却。
吸力不足	集尘盒已满。	清除灰尘。
	吸嘴堵塞。	取出堵塞物。
	吸嘴或延长管松动。	紧固组件。
	吸嘴或延长管破裂或损坏。	请更换新组件。

中文

现象	可能的原因	解决办法
吸力不足	过滤器堵塞。	旋转集尘盒并用除尘刀清除灰尘，或取下过滤器，轻轻敲打或用水清洗。
排气或主要组件过热	集尘盒已满或过滤器堵塞导致电机过热。	清除灰尘。或清洁过滤器。
发出异常噪音 / 散发恶臭	未正确安装过滤器，导致杂质进入电机。	取下集尘盒，将吸入口朝下，轻轻晃动吸入口甩掉杂质和灰尘。 若仍发出异常噪音 / 散发恶臭，可能会导致电机损坏。立即停止使用，并安排维修。

选择附件

根据特定作业选择适合的附件。
有关详细信息请联系HiKOKI授权服务中心。

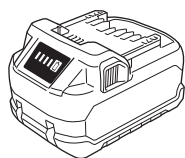

BSL36..18..

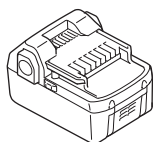

BSL18..

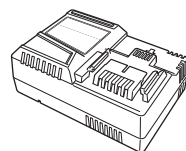
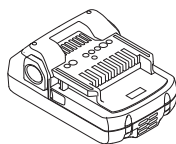

UC18YSL3
(14.4V - 18V)
充电器

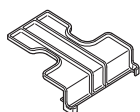

产品编号: 329897
电池盖

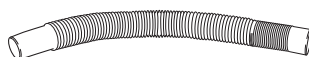

产品编号: 375373
软管

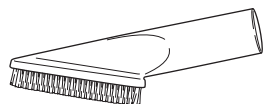

产品编号: 375371
刷头挂架

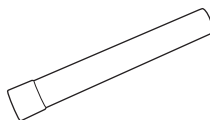

产品编号: 375375
延长管 (短)

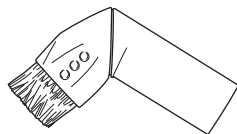

产品编号: 375372
圆刷头



产品编号: 376509
过滤

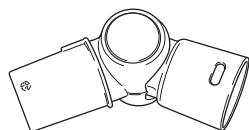

产品编号: 375374
角接头

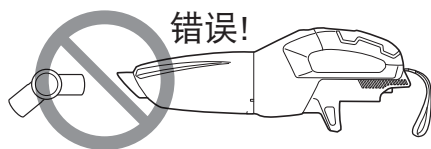

- * 不可将角接头直接安装到主要组件上。
可与延长管或其他附件配套使用。

CONTENTS

SAFETY WARNINGS FOR CORDLESS CLEANER.....	32
PRECAUTIONS FOR CORDLESS CLEANER.....	34
ADDITIONAL SAFETY WARNINGS.....	35
CAUTION ON LITHIUM-ION BATTERY.....	36
REGARDING LITHIUM-ION BATTERY TRANSPORTATION.....	38
USB DEVICE CONNECTION PRECAUTIONS.....	38
SYMBOLS.....	39
NAME OF PARTS.....	39
SPECIFICATIONS.....	40
STANDARD ACCESSORIES.....	41
APPLICATIONS.....	41
BATTERY REMOVAL / INSTALLATION.....	41
CHARGING.....	42
PRIOR TO OPERATION.....	45
THE SWITCH PANEL (R18DC).....	48
HOW TO USE.....	49
EMPTYING THE DUST CASE.....	53
HOW TO RECHARGE USB DEVICE (UC18YSL3).....	54
MAINTENANCE AND INSPECTION.....	56
TROUBLESHOOTING.....	59
SELECTING ACCESSORIES.....	61

SAFETY WARNINGS FOR CORDLESS CLEANER

WARNING

Read all safety warnings and all instructions.

Failure to follow the warnings and instructions may result in electric shock, fire and/or serious injury.

Save all warnings and instructions for future reference.

- 1) **Work area safety**
 - a) **Keep work area well lit.**
Dark areas invite accidents.
 - b) **Do not operate appliances in explosive atmospheres, such as in the presence of flammable liquids, gases or dust.**
Appliances create sparks which may ignite the dust or fumes.
 - c) **Keep children and bystanders away while operating an appliance.**
Distractions can cause you to lose control.
- 2) **Electrical safety**
 - a) **Charger plugs must match the outlet. Never modify the plug in any way.**

Unmodified plugs and matching outlets will reduce risk of electric shock.

- b) **Do not expose appliances to rain or wet conditions.**
Water entering an appliance will increase the risk of electric shock.
- c) **Do not abuse the cord of charger. Never use the cord for carrying, pulling or unplugging the charger.**
Keep cord away from heat, oil, sharp edges or moving parts.
Damaged or entangled cords increase the risk of electric shock.

3) Personal safety

- a) **Stay alert, watch what you are doing and use common sense when operating an appliance.**
Do not use an appliance while you are tired or under the influence of drugs, alcohol or medication.
A moment of inattention while operating appliances may result in serious personal injury.
- b) **Do not overreach. Keep proper footing and balance at all times.**
This enables better control of the appliance in unexpected situations.

4) Cleaner use and care

- a) **Do not force the appliance. Use the correct appliance for your application.**
The correct appliance will do the job better and safer at the rate for which it was designed.
- b) **Do not use the appliance if the switch does not turn it on and off .**
Any appliance that cannot be controlled with the switch is dangerous and must be repaired.
- c) **Disconnect the battery pack from the appliance before making any adjustments, changing accessories, or storing appliances.**
Such preventive safety measures reduce the risk of starting the appliance accidentally.
- d) **Store idle appliances out of the reach of children and do not allow persons unfamiliar with the appliance or these instructions to operate the appliance.**
Appliances are dangerous in the hands of untrained users.
- e) **Maintain appliances. Check for misalignment or binding of moving parts, breakage of parts and any other condition that may affect the appliance's operation.**
If damaged, have the appliance repaired before use.
Many accidents are caused by poorly maintained appliances.
- f) **Use the appliance and accessories etc. in accordance with these instructions, taking into account the working conditions and the work to be performed.**
Use of the appliance for operations different from those intended could result in a hazardous situation.

5) Battery pack use and care

Power can only be supplied to this appliance using the included lithium battery or one that is designated by our company.

- a) **Recharge only with the charger specified by the manufacturer.**

English

A charger that is suitable for one type of battery pack may create a risk of fire when used with another battery pack.

- b) **Use appliances only with specifically designated battery packs.**
Use of any other battery packs may create a risk of injury and fire.
- c) **When battery pack is not in use, keep it away from other metal objects, like paper clips, coins, keys, nails, screws or other small metal objects, that can make a connection from one terminal to another.**
Shorting the battery terminals together may cause burns or a fire.
- d) **Under abusive conditions, liquid may be ejected from the battery; avoid contact. If contact accidentally occurs, flush with water. If liquid contacts eyes, additionally seek medical help.**
Liquid ejected from the battery may cause irritation or burns.

6) Service

- a) **Have your appliance serviced by a qualified repair person using only identical replacement parts.**
This will ensure that the safety of the appliance is maintained.

CAUTION

Keep children and infirm persons away.

When not in use, appliances should be stored out of reach of children and infirm persons.

PRECAUTIONS FOR CORDLESS CLEANER

1. Prevent the appliance from sucking in the following: Fire or injury may result.
 - Liquids (e.g., water, oil) or damp debris.
 - Generated spark during metal grinding or cutting.
 - High temperature things, such as lighted cigarette.
 - Inflammable substances (gasoline, thinner, benzene, kerosene, paint, etc.), explosive substances (nitroglycerine, etc.), combustible substances (aluminum, zinc, magnesium, titanium, red phosphorus, yellow phosphorus, celluloid, etc.)
 - Sharp things, such as nails, razors or glass.
 - Solidification materials, such as cement powder and toner, and conductive fine dusts, such as metal powder and carbon powder.
2. Set the filter correctly before use. Do not use the appliance without the filter or with it set in a wrong position, or do not use a torn filter. May cause failures, such as motor burnout.
3. This appliance is only used indoors. Never use it outdoors. Do not use in the rain. Keep away from water or oil. Malfunction may result as this appliance is not waterproof.
4. Do not use the appliance with its suction opening or exhaust opening obstructed. The temperature of the motor may rise abnormally, causing troubles such as deformation of parts or motor burnout.

5. Do not operate the appliance when the suction opening is blocked. The motor may overheat, causing deformation of parts or malfunction of the motor.
6. When you drop or bump the appliance accidentally, check for breakage, crack, or deformation in the appliance. Breakage, crack or deformation may cause injuries.
7. When the appliance is out of condition or emits abnormal sound during use, immediately turn off the switch and request repair from your local retailer or authorized servicing agent. If you continue to use the appliance as it is, it may lead to injuries.

ADDITIONAL SAFETY WARNINGS

1. Always charge the battery at a temperature of 0–40°C.
A temperature of less than 0°C will result in over charging which is dangerous. The battery cannot be charged at a temperature greater than 40°C.
The most suitable temperature for charging is that of 20–25°C.
2. Do not use the charger continuously.
When one charging is completed, leave the charger for about 15 minutes before the next charging of battery.
3. Do not allow foreign matter to enter the hole for connecting the rechargeable battery.
4. Never disassemble the rechargeable battery and charger.
5. Never short-circuit the rechargeable battery. Short-circuiting the battery will cause a great electric current and overheat. It results in burn or damage to the battery.
6. Do not dispose of the battery in fire.
If the battery burnt, it may explode.
7. Bring the battery to the shop from which it was purchased as soon as the post-charging battery life becomes too short for practical use. Do not dispose of the exhausted battery.
8. Do not insert object into the air ventilation slots of the charger.
Inserting metal objects or inflammables into the charger air ventilation slots will result in electrical shock hazard or damaged charger.
9. When using this unit continuously, the unit may overheat, leading to damage in the motor and switch. Therefore, whenever the housing becomes hot, give the tool a break for a while.
10. Make sure that the battery is installed firmly. If it is at all loose it could come off and cause an accident.
11. Do not use the product if the tool or the battery terminals (battery mount) are deformed.
Installing the battery could cause a short circuit that could result in smoke emission or ignition.
12. Keep the tool's terminals (battery mount) free of swarf and dust.
 - Prior to use, make sure that swarf and dust have not collected in the area of the terminals.
 - During use, try to avoid swarf or dust on the tool from falling on the battery.

English

- When suspending operation or after use, do not leave the tool in an area where it may be exposed to falling swarf or dust.
Doing so could cause a short circuit that could result in smoke emission or ignition.
- 13. Always use the tool and battery at temperatures between -5°C and 40°C.

CAUTION ON LITHIUM-ION BATTERY

To extend the lifetime, the lithium-ion battery equips with the protection function to stop the output.

In the cases of 1 to 3 described below, when using this product, even if it is switched on, the motor may stop. This is not the trouble but the result of protection function.

1. When the battery power remaining runs out, the motor stops.
In such a case, charge it up immediately.
2. If the tool is overloaded, the motor may stop. In this case, switch the tool off and eliminate causes of overloading. After that, you can use it again.
3. If the battery is overheated under overload work, the battery power may stop.
In this case, stop using the battery and let the battery cool. After that, you can use it again.

Furthermore, please heed the following warning and caution.

WARNING

In order to prevent any battery leakage, heat generation, smoke emission, explosion and ignition beforehand, please be sure to heed the following precautions.

1. Make sure that swarf and dust do not collect on the battery.
 - During work make sure that swarf and dust do not fall on the battery.
 - Make sure that any swarf and dust falling on the appliance during work do not collect on the battery.
 - Do not store an unused battery in a location exposed to swarf and dust.
 - Before storing a battery, remove any swarf and dust that may adhere to it and do not store it together with metal parts (screws, nails, etc.).
2. Do not pierce battery with a sharp object such as a nail, strike with a hammer, step on, throw or subject the battery to severe physical shock.
3. Do not use an apparently damaged or deformed battery.
4. Do not use the battery for a purpose other than those specified.
5. If the battery charging fails to complete even when a specified recharging time has elapsed, immediately stop further recharging.
6. Do not put or subject the battery to high temperatures or high pressure such as into a microwave oven, dryer, or high pressure container.
7. Keep away from fire immediately when leakage or foul odor are detected.
8. Do not use in a location where strong static electricity generates.
9. If there is battery leakage, foul odor, heat generated, discolored or deformed, or in any way appears abnormal during use, recharging or storage, immediately remove it from the equipment or battery charger, and stop use.

10. Do not immerse the battery or allow any fluids to flow inside. Conductive liquid ingress, such as water, can cause damage resulting in fire or explosion. Store your battery in a cool, dry place, away from combustible and flammable items. Corrosive gas atmospheres must be avoided.

CAUTION

1. If liquid leaking from the battery gets into your eyes, do not rub your eyes and wash them well with fresh clean water such as tap water and contact a doctor immediately.
If left untreated, the liquid may cause eye-problems.
2. If liquid leaks onto your skin or clothes, wash well with clean water such as tap water immediately.
There is a possibility that this can cause skin irritation.
3. If you find rust, foul odor, overheating, discolor, deformation, and/or other irregularities when using the battery for the first time, do not use and return it to your supplier or vendor.

WARNING

If a conductive foreign matter enters in the terminal of lithium ion battery, the battery may be shorted, causing fire. When storing the lithium ion battery, obey surely the rules of following contents.

- Do not place conductive debris, nail and wires such as iron wire and copper wire in the storage case.
- Either install the battery in the appliance or store by securely pressing into the battery cover until the ventilation holes are concealed to prevent short-circuits (See Fig. 1).

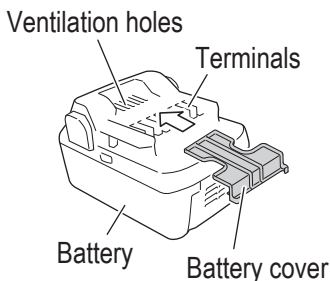

Fig. 1

REGARDING LITHIUM-ION BATTERY TRANSPORTATION

When transporting a lithium-ion battery, please observe the following precautions.

WARNING

Notify the transporting company that a package contains a lithium-ion battery, inform the company of its power output and follow the instructions of the transportation company when arranging transport.

- Lithium-ion batteries that exceed a power output of 100 Wh are considered to be in the freight classification of Dangerous Goods and will require special application procedures.
- For transportation abroad, you must comply with international law and the rules and regulations of the destination country.

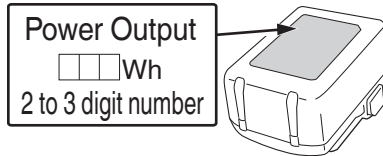

Fig. 2

USB DEVICE CONNECTION PRECAUTIONS





When an unexpected problem occurs, the data in a USB device connected to this product may be corrupted or lost. Always make sure to back up any data contained in the USB device prior to use with this product.

Please be aware that our company accepts absolutely no responsibility for any data stored in a USB device that is corrupted or lost, nor for any damage that may occur to a connected device.

SYMBOLS

WARNING

The following show symbols used for the appliance. Be sure that you understand their meaning before use.

	To reduce the risk of injury, user must read instruction manual.
	Direct current
	Rated voltage
	Warning

NAME OF PARTS

1. CLEANER

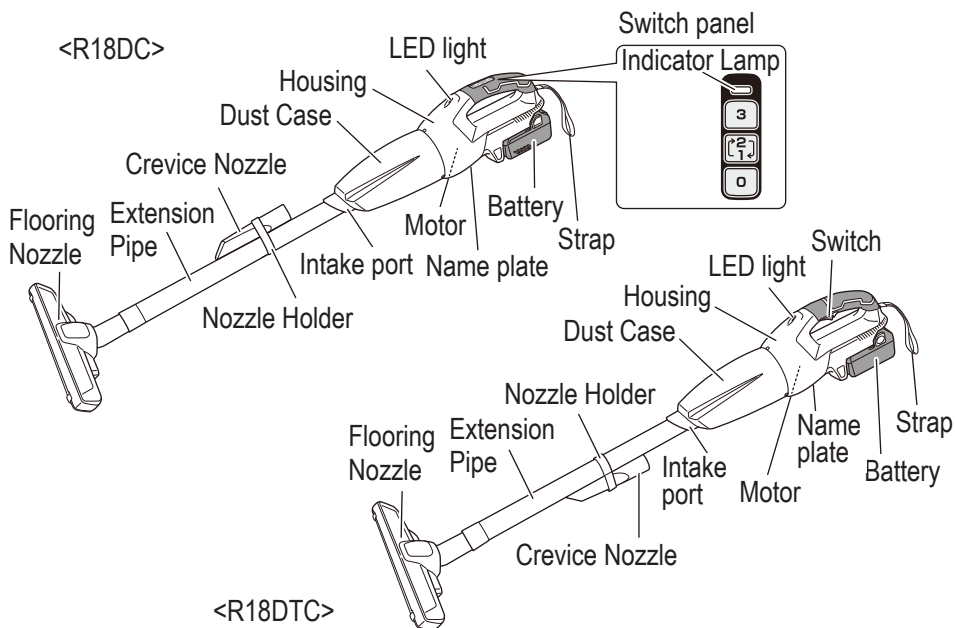

Fig. 3

SPECIFICATIONS

CLEANER

Model		R18DC	R18DTC
Voltage		18 V	
Motor		DC motor	
Continuous operating time (Battery: using BSL36A18X)	3 (HIGH)	Approx. 40 min	Approx. 40 min
	2 (MID)	Approx. 48 min	
	1 (LOW)	Approx. 66 min	
Suction Work Rate	3 (HIGH)	Approx. 40 W	Approx. 40 W
	2 (MID)	Approx. 30 W	
	1 (LOW)	Approx. 16 W	
Dust collecting capacity		560 mL	
Battery available for this appliance		Multi volt battery, BSL18 series	
Weight		1.7 kg (BSL36A18X attached)	

BATTERY (sold separately)

Model	BSL36A18X
Voltage	36 V / 18 V (Automatic Switching*1)
Battery capacity	2.5 Ah / 5.0 Ah (Automatic Switching*1)
Available cordless products*2	Multi volt series, 18 V product
Available charger	Sliding charger for lithium ion batteries

*1 The tool itself will automatically switch over.

*2 Please see our general catalogue for details.



CHARGER (sold separately)

Model	UC18YSL3
Charging voltage	14.4–18 V
Weight	0.6 kg

STANDARD ACCESSORIES

In addition to the main unit (1 unit), the package contains the accessories listed in the below.

Table 1

		R18DC (NN)	R18DTC (NN)
Flooring Nozzle		1	1
Crevice Nozzle		1	1
Extension Pipe (With Nozzle Holder)	 Nozzle Holder	1	1

Standard accessories are subject to change without notice.

APPLICATIONS

- Light-duty vacuuming of dry surfaces

BATTERY REMOVAL / INSTALLATION

1. Battery removal
Hold the handle tightly and push the battery latches to remove the battery (see **Fig. 4**).

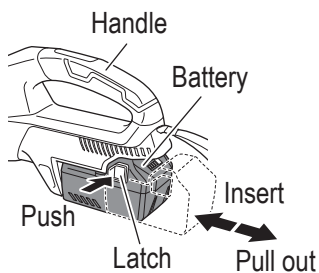

Fig. 4

CAUTION

Never short-circuit the battery.

English

2. Battery installation

Match the battery with the unit's groove and firmly press the battery in until you hear a click (see **Fig. 4**).

CHARGING

Before using the appliance, charge the battery as follows.

<UC18YSL3>

1. Connect the charger's power cord to the receptacle.
When connecting the plug of the charger to a receptacle, the charge indicator lamp will blink in red (See **Table 2**).
2. Insert the battery into the charger.
Firmly insert the battery into the charger as shown in **Fig. 5**.

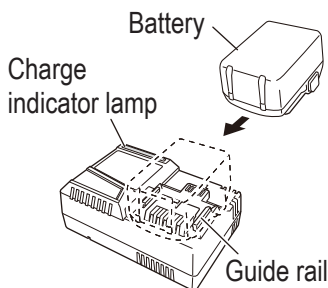







Fig. 5

3. Charging
When inserting a battery in the charger, charging will commence and the charge indicator lamp will blink in blue.
When the battery becomes fully recharged, the charge indicator lamp will light up in green. (See **Table 2**)
 - (1) Charge indicator lamp indication
The indications of the charge indicator lamp will be as shown in **Table 2**, according to the condition of the charger or the rechargeable battery.

Table 2: Indications of the charge indicator lamp

ON/OFF at 0.5 sec. intervals (RED) ■■■■ ■■■■ ■■■■	Before charging*1
Lights for 0.5 sec. at intervals of 1 sec. (BLUE) ■■■■ ■■■■	Charged at less than 50%

Lights for 1 sec. at intervals of 0.5 sec. (BLUE) 	Charged at less than 80%
Lights continuously (BLUE) 	Charged at more than 80%
Lights continuously (Continuous buzzer sound: about 6 sec.) (GREEN) 	Charging complete
ON/OFF at 0.3 sec. intervals (RED) 	Overheat standby*2
ON/OFF at 0.1 sec. intervals (Intermittent buzzer sound: about 2 sec.) (PURPLE) 	Charging impossible*3

NOTE

- *1 If the red lamp continues to blink even after the charger has been attached, check to confirm that the battery has been fully inserted.
- *2 Battery overheated. Unable to charge.
Although charging will start once the battery has cooled down even when left in situ, the best practice is to remove the battery and allow it to cool down in a shaded, well-ventilated location before charging.
- *3 Malfunction in the battery or the charger
- Fully insert the battery.
 - Check to confirm that no foreign matter is stuck to the battery mount or terminals. If there are no foreign objects, it is probable that the battery or charger is malfunctioning. Take it to your authorized Service Center.
- When the battery charger has been continuously used, the battery charger will be heated, thus constituting the cause of the failures. Once the charging has been completed, give 5 minutes rest until the next charging.

- (2) Regarding the temperatures and charging time of the battery (See **Table 3**)

Table 3

Model	UC18YSL3
Type of battery	Li-ion
Charging voltage	14.4–18 V
Temperatures at which the battery can be recharged	0°C–50°C

English

Charging time for battery capacity, approx. (At 20°C)	1.5 Ah	15 min
	2.0 Ah	20 min
	2.5 Ah	25 min
	3.0 Ah	20 min (BSL1430C, BSL1830C: 30 min)
	4.0 Ah	26 min (BSL1840M: 40 min)
	5.0 Ah	32 min
	6.0 Ah	38 min
Charging time for multi volt battery capacity, approx. (At 20°C)	1.5 Ah (× 2 unit)	20 min
	2.5 Ah (× 2 unit)	32 min
	4.0 Ah (× 2 unit)	52 min
Number of battery cells		4–10
Charging voltage for USB		5 V
Charging current for USB		2 A
Weight		0.6 kg

NOTE

- The recharging time may vary according to the ambient temperature and power source voltage.
 - If charging takes a long time
 - Charging will take longer at extremely low ambient temperatures. Charge the battery in a warm location (such as indoors).
 - Do not block the air vent. Otherwise the interior will overheat, reducing the charger's performance.
 - If the cooling fan is not operating, contact a HiKOKI Authorized Service Center for repairs.
4. Disconnect the charger's power cord from the receptacle.
 5. Hold the charger firmly and pull out the battery.

NOTE

Be sure to pull out the battery from the charger after use, and then keep it.

Regarding electric discharge in case of new batteries, etc.

As the internal chemical substance of new batteries and batteries that have not been used for an extended period is not activated, the electric discharge might be low when using them the first and second time. This is a temporary phenomenon, and normal time required for recharging will be restored by recharging the batteries 2–3 times.

How to make the batteries perform longer.

- (1) Recharge the batteries before they become completely exhausted.
When you feel that the power of the tool becomes weaker, stop using the tool and recharge its battery. If you continue to use the tool and exhaust the electric current, the battery may be damaged and its life will become shorter.
- (2) Avoid recharging at high temperatures.
A rechargeable battery will be hot immediately after use. If such a battery is recharged immediately after use, its internal chemical substance will deteriorate, and the battery life will be shortened. Leave the battery and recharge it after it has cooled for a while.

PRIOR TO OPERATION

1. Setting up and checking the work environment
Check if the work environment is suitable by following the precautions.
2. Mounting and dismounting the filter
Before using the appliance, check that the filter is securely mounted.
 - (1) Remove the dust case (**Fig. 6**)
Looking at the dust case from the intake port, turn it counterclockwise for approximately 120 degrees to align the protruding marks on the dust case and the housing, and then pull it off.

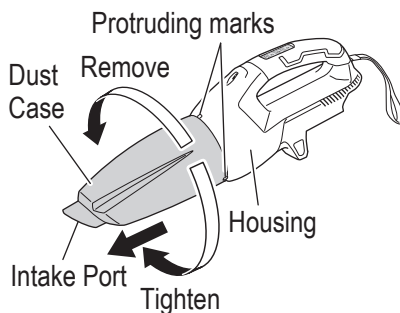

Fig. 6

English

- (2) Remove the filter. (**Fig. 7**)
Turn the filter clockwise to remove it from the housing.

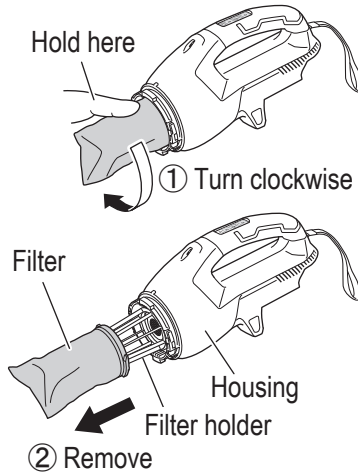

Fig. 7

- (3) Check the filter (**Fig. 8**)
Check the filter for damage and contamination.

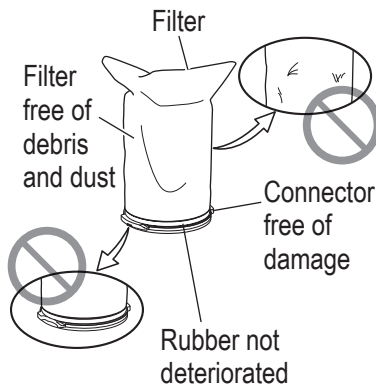

Fig. 8

- (4) Install the filter (**Fig. 9**)
 When installing the filter, press the housing on with the projections in a horizontal position. Then, turn the filter until the projections are fixed in the grooves of the housing.

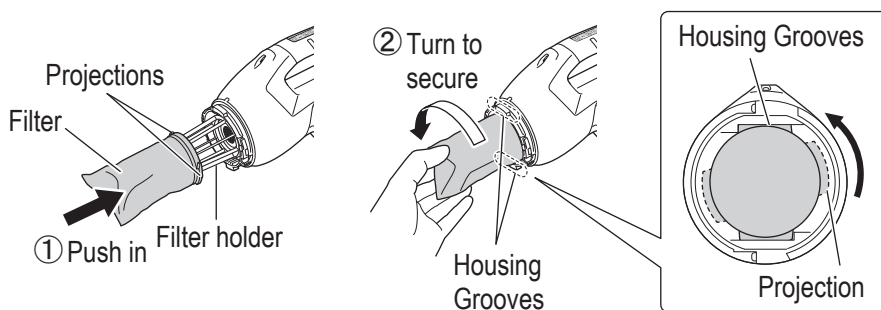

Fig. 9

- (5) Install the dust case (**Fig. 10**)
 Place the dust case over the housing, making sure that the protruding marks on both are aligned. Then, turn the dust case clockwise for approximately 120 degrees.

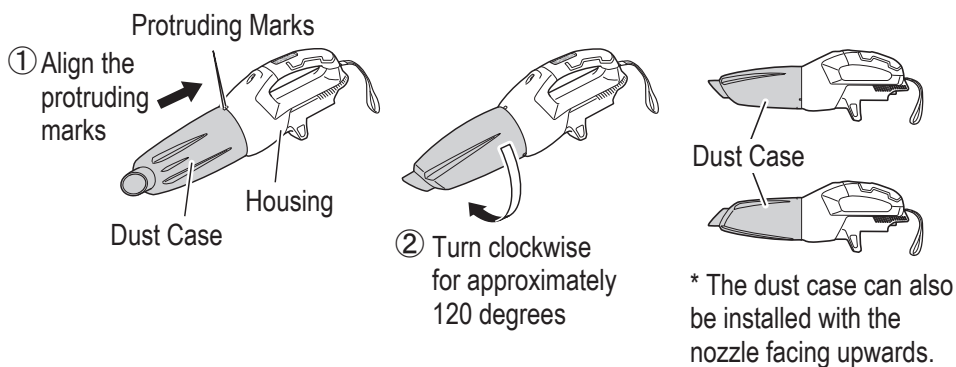

Fig. 10

NOTE

If the filter is not properly fitted, dirt or grime can enter the fan unit and cause damage or malfunction.

THE SWITCH PANEL (R18DC)

CAUTION

Do not subject the switch panel to shock or damage.

1. Switch operation (**Fig. 11**)

The vacuum of the appliance can be switched between three stages of operation, depending on your need.

When the power is off, pressing the 3 button or the 2/1 button will switch the appliance on. At the same time, the LED light will switch on. To switch between MID mode and LOW mode, press the 2/1 button.

To suppress noise when using the appliance, switch to 1 mode.

To shut off the appliance, press the Ø button. This will also switch off the LED light.

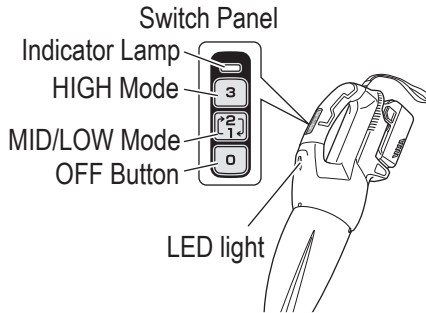

Fig. 11

Mode	Continuous operating time
	BSL36A18X
3 (HIGH)	Approx. 40 min
2 (MID)	Approx. 48 min
1 (LOW)	Approx. 66 min

* Continuous operating time will vary according to battery condition. Please use the table as a guideline.

2. The Indicator Lamp (Fig. 12)

When the battery supply is low during operation of the appliance, the indicator lamp will light up. When this occurs, please recharge the appliance.

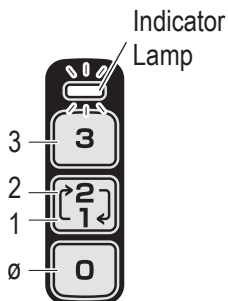

Fig. 12

HOW TO USE

WARNING

To prevent accidents when installing or removing the rechargeable battery, make sure that the appliance is switched off.

CAUTION

- Make sure that the rechargeable battery is properly installed. If not properly installed, the battery may fall out, causing injury.
- Make sure the filter is installed when operating the appliance. Failure to do so may result in injury or malfunction.

1. Verify the filter (Fig. 13)

Check to make sure the filter is installed. At the same time, check to make sure the filter is not damaged or dirty. (See "Check the filter" on page 46.)

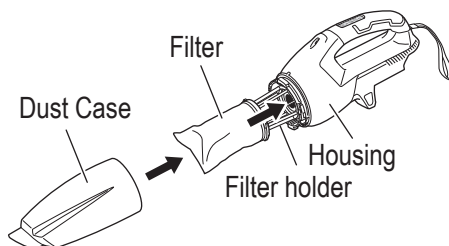

Fig. 13

English

2. Attach the nozzle (**Fig. 14**)
Depending on the operation, insert the nozzle to the intake port of the appliance. The appliance can be used without a nozzle.

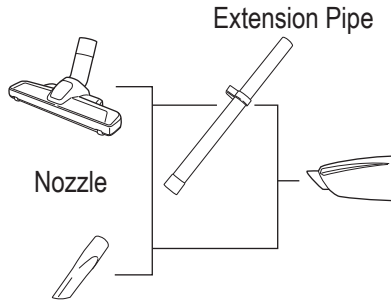

Fig. 14

NOTE

When attaching the nozzle or extension pipe, insert as you twist in the direction indicated by the arrow. (**Fig. 15**)
Twist in the direction indicated by the arrow when detaching as well.
Twisting in the opposite direction could result in detaching the dust case from the housing.

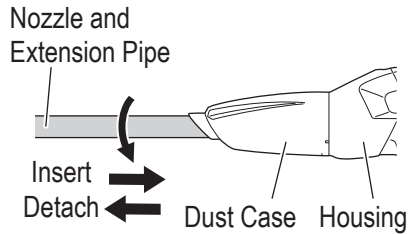

Fig. 15

3. Install the battery (**Fig. 16**)
As shown in the diagram below, firmly insert until a click is heard.

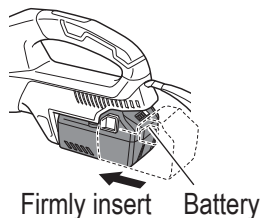

Fig. 16

4. Switch on the appliance

<R18DC>

Press the button for the mode you wish to operate. (Fig. 17)

(See "THE SWITCH PANEL (R18DC)" on page 48.)

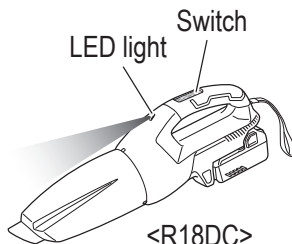

Fig. 17

<R18DTC>

When the switch is pulled, the appliance and the LED light are both activated. Release the switch and the appliance and LED light at both shut off. (Fig. 18)

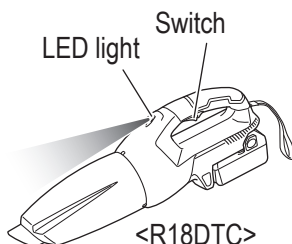

Fig. 18

CAUTION

- Do not expose directly your eye to the light by looking into the LED light. If your eye is continuously exposed to the LED light, your eye will be hurt.
- Wipe off any dirt or grime attached to the lens of the LED light with a soft cloth, being careful not to scratch the lens. Scratches on the lens of the LED light can result in decreased brightness.

English

5. Remaining battery indicator

You can check the battery's remaining capacity by pressing the remaining battery indicator switch to light the indicator lamp. (Fig. 19, Table 4)

Remaining battery indicator lamp Remaining battery indicator switch

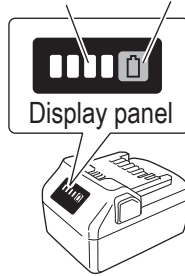

Fig. 19

The indicator will shut off approximately 3 seconds after the remaining battery indicator switch is pressed.

It is best to use the remaining battery indicator as a guide since there are slight differences such as ambient temperature and the condition of the battery.

NOTE

Also, the remaining battery indicator may vary from those equipped to a tool or charger.

Table 4

	Lights ; The battery remaining power is over 75%
	Lights ; The battery remaining power is 50%–75%.
	Lights ; The battery remaining power is 25%–50%.
	Lights ; The battery remaining power is less than 25%
	Blinks ; The battery remaining power is nearly empty. Recharge the battery soonest possible.
	Blinks ; Output suspended due to high temperature. Remove the battery from the tool and allow it to fully cool down.

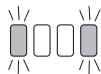

Blinks ;
Output suspended due to failure or malfunction. The problem may be the battery so please contact your dealer.

As the remaining battery indicator shows somewhat differently depending on ambient temperature and battery characteristics, read it as a reference.

NOTE

Do not give a strong shock to the switch panel or break it. It may lead to a trouble.

EMPTYING THE DUST CASE

WARNING

To prevent accidents, make sure the power is switched off and remove the rechargeable battery from the appliance.

CAUTION

- Do not subject the dust case to strong impacts as this may cause deformation or damage.
- Empty the dust case frequently and keep the appliance, filter, etc. clean. Failure to do so may reduce vacuuming efficiency or cause malfunction of the motor or odor.

1. Turn the dust case and pull it from the housing. (Fig. 20)

NOTE

Point the intake port downward as dust can spill when removing the dust case.

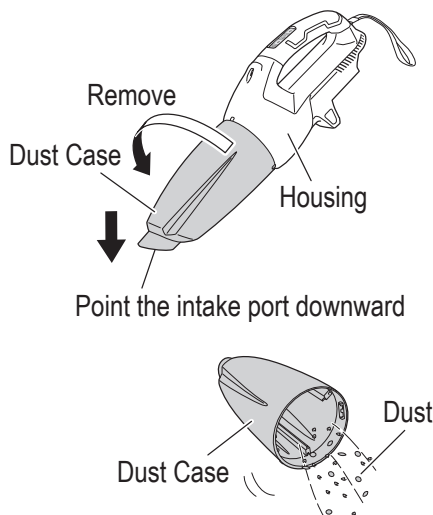

Fig. 20

English

2. Dispose the dust in the dust case.
3. If the suction does not recover after disposing the dust, clean the filter.
4. Attach the filter and dust case to the housing.

Effectively removing dust (Fig. 21)

The appliance has a built-in mechanism for scraping off dust attached to the filter when removing the dust case.

To even more effectively scrape off the dust, repeatedly turn the dust case back and forth (2 to 3 times or more).

Holding the unit so that the dust case does not detach from the housing, slightly and repeatedly turn the dust case in the indicated directions.

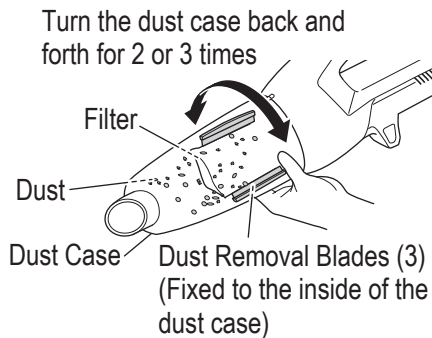

Fig. 21

HOW TO RECHARGE USB DEVICE (UC18YSL3)

WARNING

- Prior to use, check the connecting USB cable for any defect or damage. Using a defective or damaged USB cable can cause smoke emission or ignition.
- When the product is not being used, cover the USB port with the rubber cover. Buildup of dust etc. in the USB port can cause smoke emission or ignition.

NOTE

- There may be an occasional pause during USB recharging.
- When a USB device is not being charged, remove the USB device from the charger. Failure to do so may not only reduce the battery life of a USB device, but may also result in unexpected accidents.
- It may not be possible to charge some USB devices, depending on the type of device.

1. Select a charging method
Depending on the charge method selected, either the battery is inserted into the charger or the power cord is plugged into an outlet.
- Charging a USB device from a electrical outlet. (Fig. 22-a)
 - Charging a USB device and battery from an electrical outlet. (Fig. 22-b)

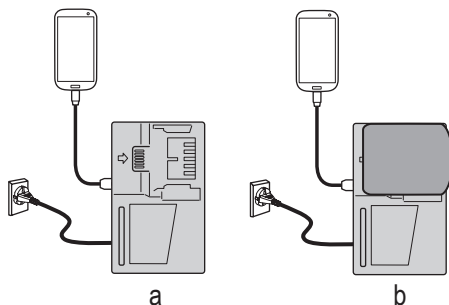

Fig. 22

2. Connect the USB cable. (Fig. 23)
Pull back the rubber cover and firmly plug in a commercially available USB cable (appropriate to the device being charged) into the USB port.

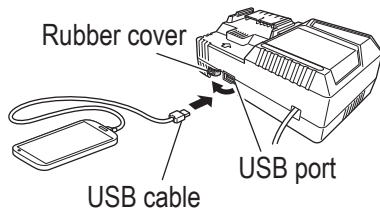

Fig. 23

3. When charging is completed
- To verify charge status, check the USB device.
 - Unplug the power cord from the electrical outlet. (Fig. 24)
 - Place the rubber cover over the USB port.

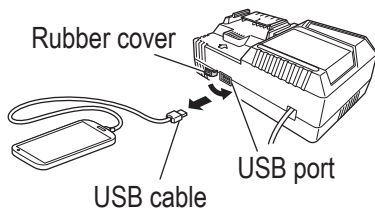

Fig. 24

MAINTENANCE AND INSPECTION

WARNING

Be sure to turned off the switch and remove the battery before maintenance and inspection.

1. Cleaning the filter

If the vacuuming efficiency is poor even when the dust case has been emptied, remove the filter and wash it in cold or warm water. (The water should not be hot to the touch.)

After washing, dry out of direct sunlight. (Fig. 25-a)

Alternatively, blow off any debris attached to the filter from the inside toward the outside with an air gun or something similar. (Fig. 25-b)

NOTE

- Do not wash the filter in a washing machine.
- Do not wash the filter in hot water or dry it by fire.
- Do not use an air gun or similar tool to clean the filter, fan filter or the appliance itself.

(Fig. 25-c)

Doing so could push dirt into the appliance and cause malfunction.

Dry off any moisture

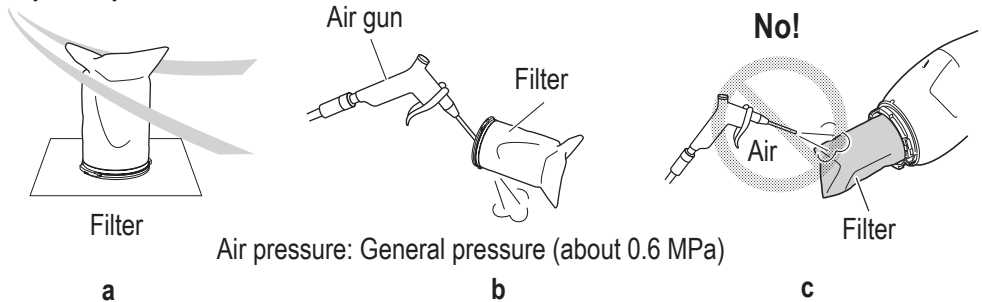

Fig. 25

2. Cleaning the fan filter (Fig. 26)

If there is dust on the fan filter, hold the cleaner with the fan filter pointing downwards to keep dust from entering the motor and lightly clean with a small brush such as a used toothbrush.

Clean with a toothbrush or similar tool
(Do not brush vigorously)

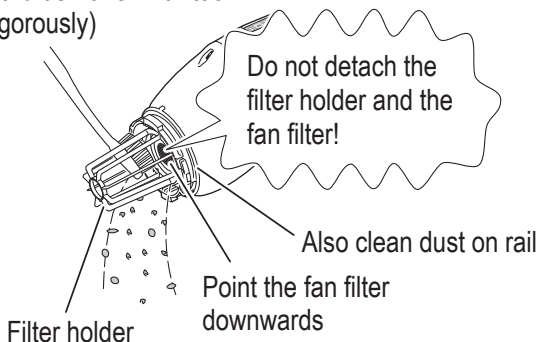

Fig. 26

3. Inspecting the flooring nozzle

Inspect the flooring nozzle to confirm that its blade is not dislodged. If the blade is dislodged, press it in until it catches on the projection.

Using with the blade dislodged may cause stains.

When replacing the blade, insert it starting from the notch in the rail, and thread it along the groove. Ensure there is no sagging throughout. (Fig. 27)

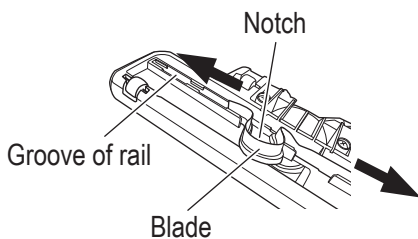

Fig. 27

4. Inspecting the mounting screws

Regularly inspect all mounting screws and ensure that they are properly tightened. Should any of the screws be loose, retighten them immediately. Failure to do so may result in serious hazard.

5. Maintenance of the motor

The motor unit winding is the very “heart” of the power tool.

Exercise due care to ensure the winding does not become damaged and/or wet with oil or water.

English

NOTE

Regularly idle the motor to clean out dirt and dust.
Damage may result if dirt or dust collects in the motor.

6. Inspection of terminals (tool and battery)
Check to make sure that swarf and dust have not collected on the terminals.
On occasion check prior, during and after operation.

CAUTION

Remove any swarf or dust which may have collected on the terminals. Failure to do so may result in malfunction.

7. Cleaning of the outside
When the tool is stained, wipe with a soft dry cloth or a cloth moistened with soapy water.
Do not use chloric solvents, gasoline or paint thinner, as they melt plastics.
8. Storage
Store the cordless cleaner in a place in which the temperature is less than 50°C, and out of reach of children.
When storing the appliance in a vertical position, hook the strap to a hanger.

NOTE

- Do not store in a location where children can easily reach or take out the appliance.
- Do not store in a damp location or in an area exposed to rainfall.
- Do not store in direct sunlight or in a location where temperatures may suddenly change.
- Do not store in a location with volatile materials that could ignite or explode.
- Do not stand the appliance against a wall without using the strap to fix it in place.
(Fig. 28) Failure to do so may result in damage from a fall.

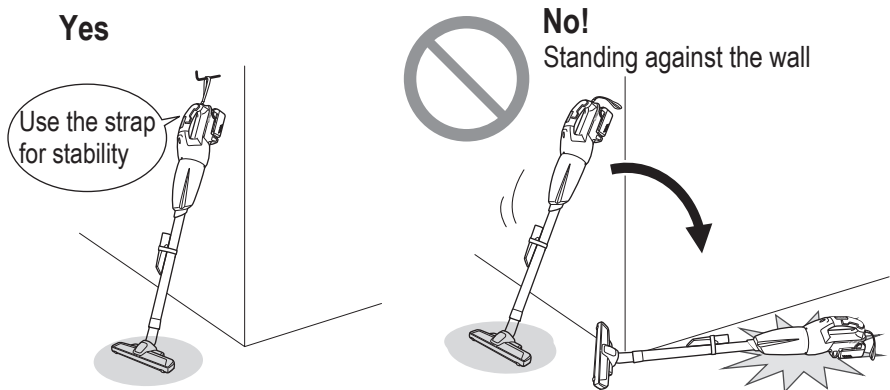

Fig. 28

NOTE**Storing Lithium-ion Batteries**

Make sure the lithium-ion batteries have been fully charged before storing them.

Prolonged storage (3 months or more) of batteries with a low charge may result in performance deterioration, significantly reducing battery usage time or rendering the batteries incapable of holding a charge.

However, significantly reduced battery usage time may be recovered by repeatedly charging and using the batteries two to five times.

If the battery usage time is extremely short despite repeated charging and use, consider the batteries dead and purchase new batteries.

CAUTION

In the operation and maintenance of appliances, the safety regulations and standards prescribed in each country must be observed.

Important notice on the batteries for the HiKOKI cordless appliances

Please always use one of our designated genuine batteries. We cannot guarantee the safety and performance of our cordless appliance when used with batteries other than these designated by us, or when the battery is disassembled and modified (such as disassembly and replacement of cells or other internal parts).

TROUBLESHOOTING

Use the inspections in the table below if the cleaner does not operate normally. If this does not remedy the problem, consult your dealer or the HiKOKI Authorized Service Center.

Symptom	Possible cause	Remedy
Cleaner doesn't run	No remaining battery power	Charge the battery.
Cleaner suddenly stopped	Fan clogged with dust, causing overload	Contact place of purchase and arrange for dismantling and cleaning.
	The battery is overheated.	Let the battery cool down.
Poor suction	Dust case is full.	Dispose the dust.
	Nozzle is plugged.	Remove the obstruction.
	Nozzle or extension pipe is loose.	Firmly tighten the unit.
	Nozzle or extension pipe is cracked or damaged.	Exchange the unit with a new one.

English

Symptom	Possible cause	Remedy
Poor suction	Filter is clogged.	Turn the dust case and scrape off dust with dust removal blade, or remove the filter and lightly strike it or wash with water.
Exhaust or the main unit is hot	The motor is overheating because the dust case is full, or the filter is clogged.	Dispose the dust. Or else, clean the filter.
Abnormal noise/foul odor	Filter is not properly installed, resulting in foreign matter getting into the motor.	Remove the dust case, point the intake port downward and gently shake to remove foreign matter and dust. Should abnormal noise/foul odor persist, the motor may be damaged. Immediately discontinue use and arrange for repairs.

SELECTING ACCESSORIES

Select accessories that are suited to a specific task.
For details contact HiKOKI Authorized Service Center.

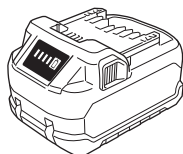

BSL36..18..

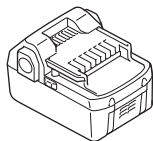

BSL18..

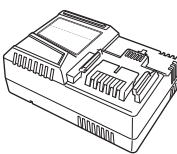
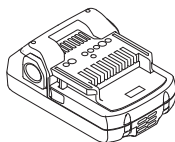

UC18YSL3
(14.4 V - 18 V)
Charger

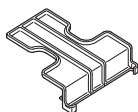

Part Number: 329897
Battery cover



Part Number: 375373
Flexible Hose

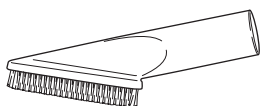

Part Number: 375371
Rack Brush

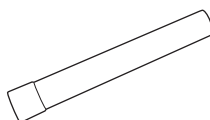

Part Number: 375375
Extension Pipe (Short)

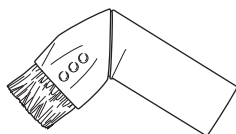

Part Number: 375372
Round Brush



Part Number: 376509
Filter

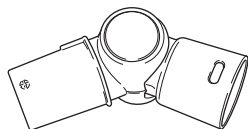

Part Number: 375374
Angle Joint

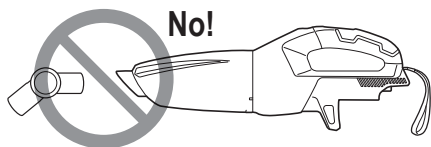

- * Angle joint cannot be directly installed to the main unit.
Use it as a set with the extension pipe or other accessory.

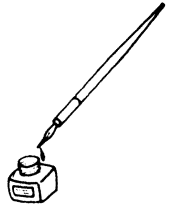

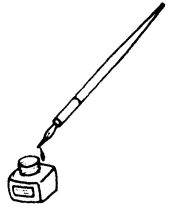

服务中心
高壹工机商业(上海)有限公司
上海市闵行区浦江工业园区三鲁路3585号7幢3楼

制造商
广东高壹工机有限公司
广东省广州市番禺区化龙镇工业路富裕围工业村

Koki Holdings Co., Ltd.

307
编号：C99278251 G
发行日期：2023年7月
中国印刷