

HIKOKI

充电式锤钻

Cordless Rotary Hammer

DH 3640DB

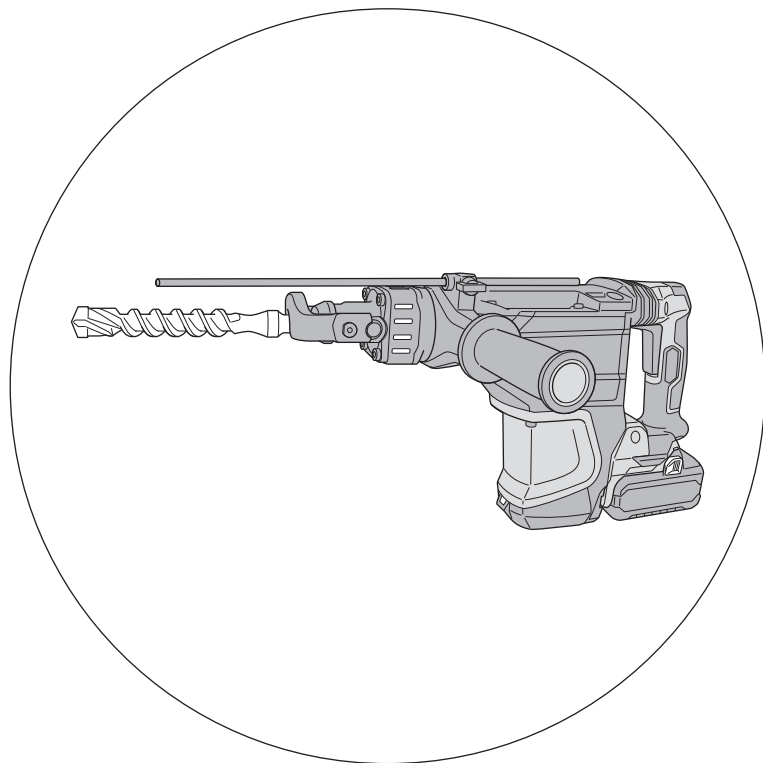

保留备用

Keep for future reference



使用说明书

Handling instructions

目次

电动工具通用安全警告.....	2	电池的拆卸 / 安装法.....	13
充电式锤钻安全警告.....	5	充电.....	13
其它安全警告.....	5	如何为 USB 设备充电.....	16
锂离子电池使用注意事项.....	7	作业之前.....	17
锂离子电池运输.....	8	使用方法.....	22
USB 设备连接器使用注意事项 (UC18YSL3).....	9	钻心的使用方法.....	23
符号.....	9	反作用力控制.....	25
零件名称.....	10	操作上的注意事项.....	25
规格.....	11	维护和检查.....	26
标准附件.....	12	故障排除.....	29
用途.....	12	选择附件.....	32

电动工具通用安全警告

⚠ 警告！

阅读电动工具附带的所有安全警告、说明、插图和规格说明。
不遵照以下说明会导致电击、着火和 / 或严重伤害。

保存所有警告和说明书以备查阅。

在所有下列的警告中术语“电动工具”指市电驱动(有线)电动工具或电池驱动(无线)电动工具。

1) 工作场地的安全

- a) 保持工作场地清洁和明亮。
混乱和黑暗的场地会引发事故。
- b) 不要在易爆环境，如有易燃液体、气体或粉尘的环境下操作电动工具。
电动工具产生的火花会点燃粉尘或气体。
- c) 让儿童和旁观者离开后操作电动工具。
注意力不集中会使操作者失去对工具的控制。

2) 电气安全

- a) 电动工具插头必须与插座相配。绝不能以任何方式改装插头。
需接地的电动工具不能使用任何转换插头。
未经改装的插头和相配的插座将减少电击危险。
- b) 避免人体接触接地表面，如管道、散热片和冰箱。
如果你身体接地会增加电击危险。
- c) 不得将电动工具暴露在雨中或潮湿环境中。
水进入电动工具将增加电击危险。

- d) 不得滥用电线。绝不能用电线搬运、拉动电动工具或拔出其插头。使电线远离热源、油、锐边或运动部件。
受损或缠绕的软线会增加电击危险。
- e) 当在户外使用电动工具时，使用适合户外使用的外接软线。
适合户外使用的软线将减少电击危险。
- f) 如果在潮湿环境下操作电动工具是不可避免的，应使用剩余电流动作保护器（RCD）。
使用RCD可减小电击危险。

3) 人身安全

- a) 保持警觉，当操作电动工具时关注所从事的操作并保持清醒。
当你感到疲倦，或在有药物、酒精或治疗反应时，不要操作电动工具。
在操作电动工具时瞬间的疏忽会导致严重人身伤害。
- b) 使用个人防护装置。始终佩戴护目镜。
安全装置，诸如适当条件下使用防尘面具、防滑安全鞋、安全帽、听力防护等装置能减少人身伤害。
- c) 防止意外起动。确保开关在连接电源和 / 或电池盒、拿起或搬运工具时处于关断位置。
手指放在已接通电源的开关上或开关处于接通时插入插头可能会导致危险。
- d) 在电动工具接通之前，拿掉所有调节钥匙或扳手。
遗留在电动工具旋转零件上的扳手或钥匙会导致人身伤害。
- e) 手不要伸展得太长。时刻注意立足点和身体平衡。
这样在意外情况下能很好地控制电动工具。
- f) 着装适当。不要穿宽松衣服或佩戴饰品。让衣服、手套和头发远离运动部件。
宽松衣服、佩饰或长发可能会卷入运动部件中。
- g) 如果提供了与排屑、集尘设备连接用的装置，要确保它们连接完好且使用得当。
使用这些装置可减少尘屑引起的危险。
- h) 请勿因频繁使用工具的熟悉感而掉以轻心，忽视工具的安全性原则。
粗心的行为可能会导致瞬间发生严重伤害。

4) 电动工具使用和注意事项

- a) 不要滥用电动工具，根据用途使用适当的电动工具。
选用适当设计的电动工具会使你工作更有效、更安全。
- b) 如果开关不能接通或关断工具电源，则不能使用该电动工具。
不能用开关来控制的电动工具是危险的且必须进行修理。
- c) 在进行任何调整、更换附件或存放电动工具之前，必须从电源上拔掉插头和 / 或取下电池盒（如果可拆卸）。
这种防护性措施将减少工具意外起动的危险。

- d) 将闲置不用的电动工具贮存在儿童所及范围之外，并且不要让不熟悉电动工具或对这些说明不了解的人操作电动工具。
电动工具在未经培训的用户手中是危险的。
- e) 维护电动工具和附件。检查运动件是否调整到位或卡住，检查零件破损情况和影响电动工具运行的其他状况。如有损坏，电动工具应在使用前修理好。
许多事故由维护不良的电动工具引发。
- f) 保持切削刀具锋利和清洁。
保养良好的有锋利切削刃的刀具不易卡住而且容易控制。
- g) 按照使用说明书，考虑作业条件和进行的作业来使用电动工具、附件和工具的刀头等。
将电动工具用于那些与其用途不符的操作可能会导致危险。
- h) 保持手柄和抓握表面干燥、清洁，远离油和油脂。
如果手柄和抓握表面湿滑，可能导致在发生意外情况时，无法安全操作和控制工具。

5) 电池式工具使用和注意事项

- a) 只用制造商规定的充电器充电。
将适用于某种电池盒的充电器用到其他电池盒时会发生着火危险。
- b) 只使用配有特制电池盒的电动工具。
使用其他电池盒会发生损坏和着火危险。
- c) 当电池盒不用时，将它远离其他金属物体，例如回形针、硬币、钥匙、钉子、螺钉或其他小金属物体，以防一端与另一端连接。
电池端部短路会引起燃烧或火灾。
- d) 在滥用条件下，液体会从电池中溅出；避免接触。如果无意间碰到了，用水冲洗。如果液体碰到了眼睛，还要寻求医疗帮助。
从电池中溅出的液体会发生腐蚀或燃烧。
- e) 请勿使用损坏或改装的电池盒或工具。
损坏或改装的电池可能会引发突发状况，导致火灾、爆炸或受伤。
- f) 请勿将电池盒或工具暴露在有火源或高温环境中。
如果暴露在有火源或 130 度以上高温的环境中，可能引起爆炸。
- g) 请完全按照充电说明进行操作，不要在说明中规定的温度范围外的环境中对电池盒或工具充电。
充电不当或在规定温度范围外的环境中充电可能会导致电池损坏，增加发生火灾的风险。

6) 维修

- a) 将你的电动工具送交专业维修人员，使用同样的备件进行修理。
这样将确保所维修的电动工具的安全性。
- b) 请勿维修已损坏的电池盒。
需由制造商或经授权的服务供应商进行维修。

注意！

不可让儿童和体弱人士靠近工作场所。

应将不使用的工具存放在儿童和体弱人士接触不到的地方。

充电式锤钻安全警告

所有操作的安全说明

1. 戴好耳罩。

暴露在噪声中会引起听力损伤。

2. 如果随工具提供辅助手柄，请使用。

操作失手会引起人身伤害。

3. 在操作过程中，切削附件可能会触碰到隐藏的线缆，因此请握住电动工具的绝缘夹持面。

切削附件碰到带电导线会使工具外露的金属零件带电从而使操作者受到电击。

使用带锤钻的长钻头时的安全说明

4. 务必以低速开始钻孔，并始终将钻头尖端接触工件。

在更高的速度下，如果钻头不接触工件而自由旋转，则其可能会弯曲，从而导致人身伤害。

5. 仅使用钻头以直线施加压力，并且请勿施加过大压力。

钻头可能会弯曲，导致破损或失控，从而造成人身伤害。

其它安全警告

1. 勿让杂质进入可充电电池的连接口内。

2. 切勿拆卸可充电电池或充电器。

3. 切勿使可充电电池短路。使电池短路将会造成很大的电流和过热，从而烧坏电池。

4. 请勿将电池丢入火中。电池受热将会爆炸。

5. 长时间连续使用本装置，可能会导致机体过热，对电机及开关造成损害，因此使用本机请勿连续超过 15 分钟。

6. 请勿将异物插入充电器的通风口。将金属物体或易燃物插入充电器的通风口会导致触电事故或损坏充电器。

7. 充电后的电池寿命太短不够使用时，请尽快将本电池送往购买时的经销店。请勿将用过的电池乱丢。

8. 对墙壁、地板或天花板进行钻碎、钻凿或钻孔作业前，应彻底查明里面是否敷设电缆或导管。

9. 确认电源开关已切断。若电源开关接通，则安装电池后，电动工具将出其不意地立刻转动，从而导致严重事故。

中文

10. 作业过程中或之后切勿触摸钻头。

作业过程中钻头会变得很烫，如果触摸，可能导致严重灼伤。

11. 使用锤钻时，应牢牢握住工具的操作柄和侧柄。否则，所产生的反作用力会将孔钻歪，甚至会造成危险。

12. 佩戴防尘口罩

不要吸入在钻凿作业过程中产生的有害粉尘。粉尘会危及到自身和旁观者的身体健康。

13. 确保电池已牢固安装到位。如果电池松动，则会脱落出来，导致意外。

14. 为避免意外事故，请务必在更换附件、存储、搬运前或不使用工具时关闭开关并取出电池。

15. 安装工具

○ 为避免意外事故，请务必关闭开关并取出电池。

○ 当使用尖钻、钻头工具时，请务必使用本公司原装配件。

○ 清洁钻头的柄部分。然后用滑脂或机油涂抹柄部分。

○ 拉拽钻头以检查是否完全插紧。

16. 旋钻 + 锤击

钻头碰到建筑物的钢筋时会立即停止转动，该电动锤钻将随即转动。因此，请旋紧侧柄，并握住操作柄和侧柄。

17. 请勿使用工具或电池端子（电池安装部位）明显变形的产品。

否则，安装电池后可能会短路，造成冒烟或起火。

18. 请清除工具端子（电池安装部位）上的削屑和灰尘。

○ 使用前请确保电池上没有堆积削屑和灰尘。

○ 在使用过程中，请尽量避免工具上的削屑或灰尘掉落在电池上。

○ 暂时不使用工具时或使用后，应将工具存放在不会掉落削屑或灰尘的地方。否则可能短路，造成冒烟或起火。

19. 请勿直视光源。这些行为可能会导致眼睛不适。

用软布仔细擦拭附着在 LED 灯镜片上的灰尘或污垢，小心不要划伤镜片。

如果划伤 LED 灯的镜片，可能会导致亮度减弱。

20. 请在 $-5 - 40^{\circ}\text{C}$ 环境下使用本工具及电池。

21. 请始终在 0 至 40°C 的环境温度下对电池进行充电。

22. 操作时请确保如图 1 所示牢牢地握住工具。



图 1

锂离子电池使用注意事项

为延长使用期限，锂离子电池备配停止输出的保护功能。

若是在使用本产品时发生下列 1 至 3 的情况，即使按下开关，马达也可能停止。这并非故障，而是启动保护功能的结果。

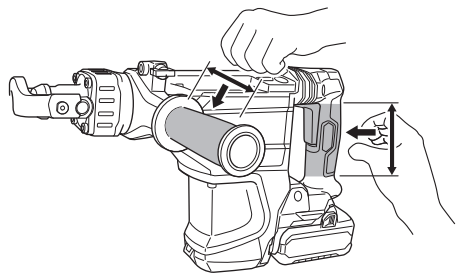
1. 在残留的电池电力即将耗尽时，马达会停止。
在这种情况下，请立即予以充电。
 2. 若工具超过负荷，马达亦可能停止。在这种情况下，请松开工具的开关，试着消除超过负荷的原因。之后您就可以再度使用。
 3. 若电池在过载工作情况下过热，电池电力可能会中止。
在这种情况下，请停止使用电池，让电池冷却。之后您就可以再度使用。
- 此外，请留心下列的警告及注意事项。

警告！

为防止发生电池漏电、发热、冒烟、爆炸及提前点燃，请确保留意下列事项。

1. 确保电池上没有堆积削屑及灰尘。
 - 在工作时确定削屑及灰尘没有掉落在电池上。
 - 确定所有工作时掉落在电动工具上的削屑和灰尘没有堆积在电池上。
 - 请勿将未使用的电池存放在曝露于削屑和灰尘的位置。
 - 在存放电池之前，请清除任何可能附着在上面的削屑和灰尘，并请切勿将它与金属零件（螺丝、钉子等）存放在一起。
2. 请勿以钉子等利器刺穿电池、以铁锤敲打、踩踏、丢掷电池，或将其剧烈撞击。
3. 切勿使用明显损坏或变形的电池。
4. 使用电池时请勿颠倒电极。
5. 请勿直接连接电源插座或汽车点烟器孔座。
6. 请依规定方式使用电池，切勿移作他用。
7. 如果已过了再充电时间，电池仍无法完成充电，请立即停止继续再充电。
8. 请勿将电池放置于高温或高压处，例如微波炉、烘干机或高压容器内。
9. 在发觉有渗漏或异味时，请勿接近远离火源。
10. 请勿在会产生强烈静电的地方使用。
11. 如有电池渗漏、异味、发热、褪色或变形，或在使用、充电或存放时出现任何异常，请立即将它从装备或电池充电器拆下，并停止使用。
12. 请勿浸泡电池或让任何液体流入电池内部。导电液体进入（如水），可能造成电池损坏，甚至可导致火灾或爆炸。将电池存放在阴凉、干燥的地方，远离易燃物品。必须避免将电池置于腐蚀性气体环境中。

注意！

1. 若电池渗漏出的液体进入您的眼睛，请勿搓揉眼睛，并以自来水等干净清水充分冲洗，立刻送医。
若不加以处理，液体可能会导致眼睛不适。
2. 若液体渗漏至您的皮肤或衣物，请立即以自来水等清水冲洗。
上述情况可能会使皮肤受到刺激。
3. 若初次使用电池时发现生锈、异味、过热、褪色、变形及 / 或其它异常情况时，请勿使用并将该电池退还给供货商或厂商。

警告！

如果有导电异物进入锂电池，可能发生短路，并有发生火灾危险的可能。请在贮存电池时，遵守如下事项。

- 请不要在电池盒内放置导电物体，如钉子、钢丝、铜丝或其他电线。
- 或者将电池装在电动工具中，或者在牢固按入电池盖并挡住通风孔后再存放，以防止短路（参照图 2）。



图 2

锂离子电池运输

当运输一个锂离子电池，请注意以下预防措施。

警告！

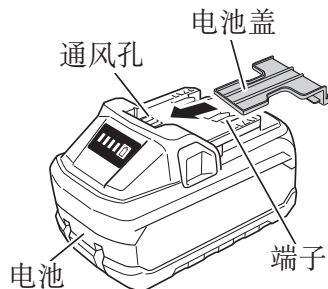
告知运输公司，包装内包含一个锂离子电池，告知该公司其功率输出并且要按照运输公司的指引安排运输。

- 功率输出超过 100Wh 的锂离子电池被视作危险物品运输分类并且需要特别申请程序。
- 对于境外运输，您必须遵守国际法以及输入国的规章和条例。
- 如果电动工具安装了 BSL36B18X，则输出功率将超过 100Wh，装置将被视作危险物品运输分类。



图 3

USB 设备连接器使用注意事项 (UC18YSL3)

发生意外情况时，本产品连接的 USB 中保存的数据可能发生损坏或丢失。使用本产品前，请务必备份 USB 设备中的数据。

请注意，如 USB 设备中存储的数据发生损坏、丢失或连接的设备发生损坏，本公司概不负责。

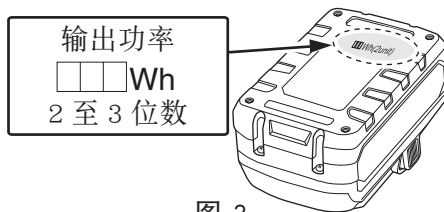
符号

警告！

如下所示的符号用于本机。使用前请务必理解其含意。

	为降低伤害风险，用户必须阅读使用说明书	n_0	空载转速
	直流电	/min	每分钟的振动次数
V	额定电压		警告

零件名称

1. 电动工具



图 4

2. 电池

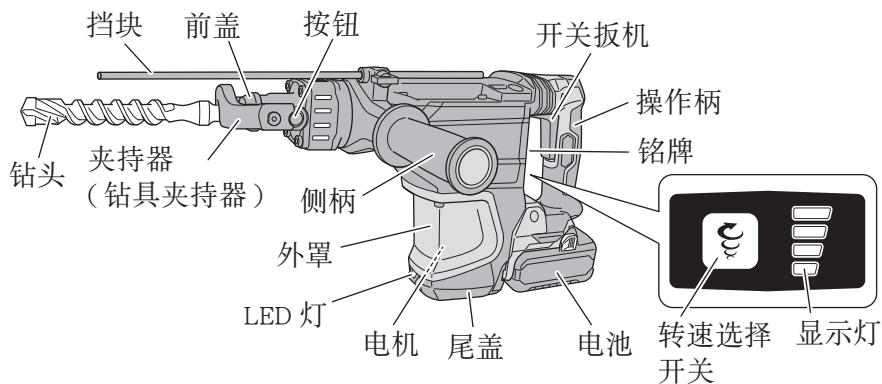

图 5

3. 电池充电器

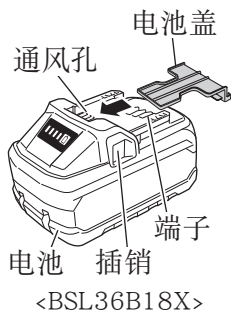

图 6

规格

电动工具

型式	DH3640DB	
电压	36V	
无负荷速度	250 – 500/min	
满载锤击率	1400 – 2800/min	
能力	钻头	40mm
	钻心	105mm
电池 *	型号	BSL36B18X : 锂离子电池 36V / 18V (4.0Ah / 8.0Ah, 10 节)
重量	7.2kg (BSL36B18X : 已安装)	

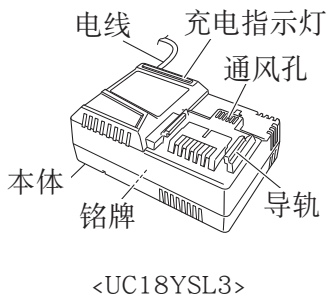
* 本工具不适用以下电池 (BSL3660/3626X/3626/3625/3620、BSL18xx 和 BSL14xx 系列)。

充电器

型式	UC18YSL3
充电电压	14.4 – 18V
重量	0.6kg

标准附件

除了主机（1 台）外，产品包中还包括表中所列的附件。

表 1

		DH3640DB
侧柄		1
挡块		1
润滑油		1
充电器（UC18YSL3）		1
电池（BSL36B18X）		2
电池盖		2
壳体（塑料模制品）		1

用途

- 钻开锚栓孔
- 对混凝土钻孔
- 混凝土破碎、凿平、挖掘、切屑
（部分用途需与选购件配合使用）

电池的拆卸 / 安装法

1. 电池的安装法

将电池对准工具操作柄内的凹槽，使其滑入到位。

请务必一直插到底，直至随着轻微的“咔哒”一声电池锁定到位，否则，电池可能会从工具中意外掉出，对您或您周围的人造成伤害（参照图 7）。



图 7

2. 电池的拆卸法

降下止动杆以松开锁。同时按两侧的插销，滑出电池（图 8）。

注意！

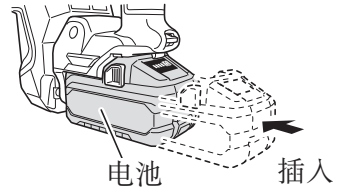
切勿使电池短路。



图 8

充电

使用电动工具之前，按下述方法将电池进行充电。

1. 将充电器的电源线连接到插座。

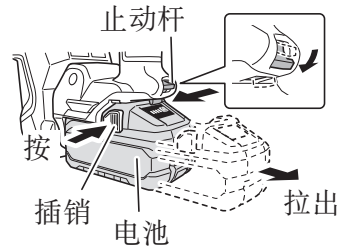
将充电器插头连接到插座时，充电指示灯闪烁红色（间隔为 1 秒）。

2. 将电池插入充电器。

如图 9 所示，将电池紧紧地插入充电器。



图 9

3. 充电

将电池插入充电器后，充电指示灯将呈蓝色闪烁。



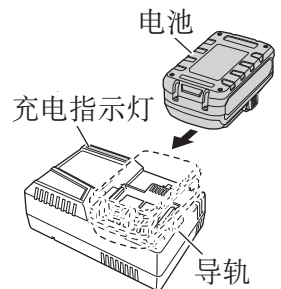



电池完全充电后，充电指示灯将持续点亮呈绿色。

(参照表 2)

(1) 充电指示灯的指示状态

根据充电器或可充电电池的情况，充电指示灯的显示如表 2 所示。

表 2

充电指示灯的指示状态				
充电指示灯 (红 / 蓝 / 绿 / 紫)	充电前	闪烁 (红)	点亮 0.5 秒钟。不点亮 0.5 秒钟。(熄灭 0.5 秒钟) 	插入电源
	充电时	闪烁 (蓝)	点亮 0.5 秒钟。不点亮 1 秒钟。(熄灭 1 秒钟) 	电池电量低于 50%
		闪烁 (蓝)	点亮 1 秒钟。不点亮 0.5 秒钟。(熄灭 0.5 秒钟) 	电池电量低于 80%
		点亮 (蓝)	连续点亮 	电池电量高于 80%
	充电完成	点亮 (绿)	连续点亮  (发出持续蜂鸣声：约 6 秒)	
	过热 待机	闪烁 (红)	点亮 0.3 秒钟。不点亮 0.3 秒钟。(熄灭 0.3 秒钟) 	电池过热。无法充 电 (电池冷却后将 开始充电)
	无法 充电	闪动 (紫色)	点亮 0.1 秒钟。不点亮 0.1 秒钟。(熄灭 0.1 秒钟)  (发出断续蜂鸣声：约 2 秒)	电池或充电器故障

- (2) 可充电电池温度和充电时间相关资料。
温度和充电时间如表 3 所示

表 3

		充电器		UC18YSL3				
电池	电池类型	锂离子电池						
	电池可充电温度	-10°C - 50°C						
	充电电压	V	14.4		18			
	充电时间 (环境温度 20°C)	分钟	BSL14xx 系列		BSL18xx 系列		多电压系列	
			(4 节)	(8 节)	(5 节)	(10 节)	(10 节)	
			BSL1415S : 15 BSL1415 : 15 BSL1415X : 15 BSL1420 : 20 BSL1425 : 25 BSL1430C : 30	BSL1430 : 20 BSL1440 : 26 BSL1450 : 32 BSL1460 : 38	BSL1815S : 15 BSL1815 : 15 BSL1815X : 15 BSL1820 : 20 BSL1825 : 25 BSL1830C : 30 BSL1850C : 32	BSL1830 : 20 BSL1840 : 26 BSL1850 : 32 BSL1860 : 38	BSL36A18 : 32 BSL36A18X : 32 BSL36B18 : 52 BSL36B18X : 52	
USB	充电电压	V	5					
	充电电流	A	2					

注：

充电时间可能会因环境温度和电源电压而异。

- 从电源插座拔下充电器的电源线。
- 握紧充电器并取出电池。

注：

充电后，先将电池从充电器中取出，然后妥善保存。

关于新电池的放电。

新电池内部的化学物质未被激活或电池长时间不使用时，初次或第二次使用时需要将其放电至较低电量。这只是暂时现象，将电池充电 2-3 次即可恢复为充电所需的正常时间。

较长时间保持电池性能的方法

- 在电池电力完全耗尽之前进行充电。

感到电动工具的能力变弱时，请停止使用并给电池充电。若您继续使用电动工具并耗尽电力，电池可能会损坏或其使用寿命缩短。

(2) 避免在高温环境中充电。

使用后可充电电池的温度将迅速升高。若使用后立即对这种电池进行充电，其内部化学物质会劣化，电池使用寿命将缩短。请稍等片刻，待电池冷却后再进行充电。

注意！

- 如果电池长时间放置在阳光直射的地方或者刚刚使用完毕时，电池会变热。如果此时对电池充电，充电器的充电指示灯会点亮 0.3 秒钟，然后熄灭 0.3 秒钟（熄灭 0.3 秒钟）。此时请等待电池冷却后再开始充电。
- 充电指示灯闪动（闪动间隔为 0.2 秒钟）时，请检查充电器的电池连接器内是否有异物并加以清除。如没有异物，则可能是电池或充电器发生了故障。请将其送往当地授权服务中心。
- 因内置的微电脑需要约 3 秒钟才能确认正用 UC18YSL3 充电的电池已被取出，因此请等待 3 秒钟后再重新插入电池继续充电。如果在不到 3 秒内就插入电池，则电池可能充电不正常。

如何为 USB 设备充电

警告！

- 使用之前请检查 USB 连接线缆是否有破损或损坏。
使用有破损或损坏的 USB 线缆可能会导致冒烟或着火。
- 不使用产品时，请用橡胶盖封好 USB 端口。
USB 端口中落入灰尘等可能会导致冒烟或着火。

注：

- USB 充电过程中，可能会有偶尔暂停。
- USB 设备未充电时，请将充电器上拔下 USB 设备。
否则不仅会减少 USB 设备的电池寿命，还会导致意外事故。
- 根据设备类型，可能无法对部分 USB 设备进行充电。

(1) 选择充电方式

- 将 USB 设备插入插座进行充电 (图 10-a)。
- 将 USB 设备和电池插入插座进行充电。(图 10-b)



图 10

(2) 连接 USB 线缆。(图 11)

拔下橡胶盖并将市售的 USB 线缆 (匹配充电的设备) 紧紧插入 USB 端口。

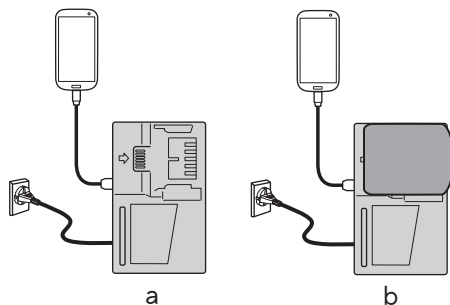

图 11

(3) 充电完成时

- 检查 USB 设备以检验充电状态。
- 从插座中拔下电源线。(图 12)
- 用橡胶盖盖住 USB 端口。

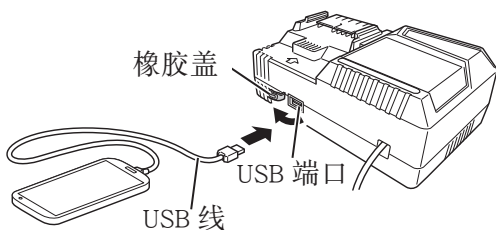

图 12

作业之前

警告！

为避免意外事故，请务必在安装或拆卸钻头及其他配件时关闭开关并断开电池。工作休息和停止工作期间，应断开电源开关。

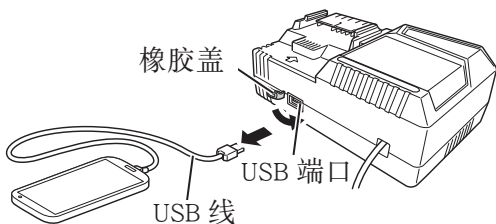
1. 电源开关

确认电源开关已切断。若电源开关接通，则插入电池后，电动工具将出其不意地立刻转动，从而导致严重事故。

2. 确认环境条件：

确认工作场所条件合适，且符合规定的预防措施。

中文

3. 安装侧手柄

(1) 旋转侧手柄以进行拆卸。(图 13)



图 13

(2) 将带子置于带子安装区域上，并将带子上的两个孔对准手柄螺栓的“T”部分。(图 14, 15)



图 14

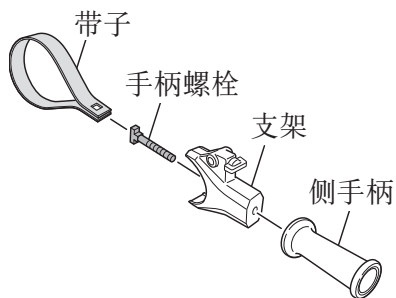

图 15

(3) 在握住带子确保手柄螺栓不会松动的同时，将手柄螺栓插入支架。(图 16)

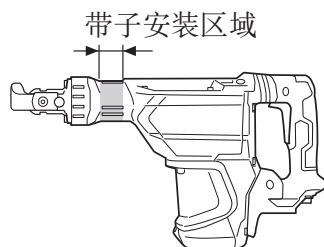

图 16

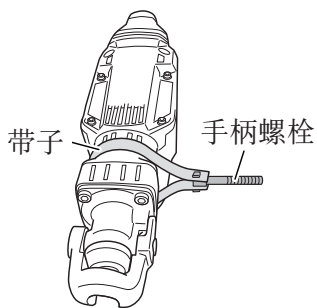
- (4) 调整带子，使其位置适合于作业，并旋转侧手柄以便紧固带子。确保带子牢牢紧固。(图 17)

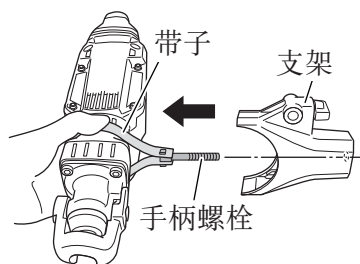

图 17

4. 如何安装工具

注意！

对于例如钻头和尖钻等工具，请仅使用 HIKOKI 正品部件。

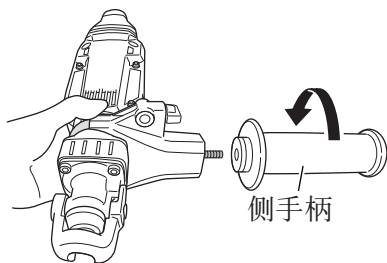
- (1) 先擦净，然后将附带的润滑油（装于管中）涂于工具柄上（图 18）。
- (2) 按下按钮，向箭头方向 ① 轻轻抬起夹持器。如图 19 所示，按动按钮并使其固定，以便挂住夹持器边缘。
- (3) 从按钮上松开手指，再向箭头方向 ① 抬起夹持器。

注：

第 1 次当夹持器抬起时，从按钮上松开手指。如果按钮保持压下状态，夹持器的边缘和手指接触，则夹持器不能抬起。

- (4) 将工具柄全部插入前盖六角孔内。
- (5) 将夹持器复位卡紧工具。
- (6) 试拉工具以确认其被完全锁定。

注：

按相反的次序拆除。

5. 当按钮没有顺畅动作时

当按钮没有顺畅动作时，用金属丝等从内部通过出口清除污垢，然后注入润滑油并多次按下按钮使其动作舒畅。(图 20)



图 18



图 19

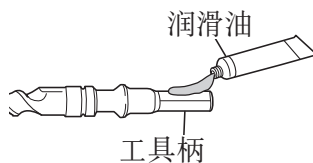

图 20

6. 调控转数和锤击数 (图 21)

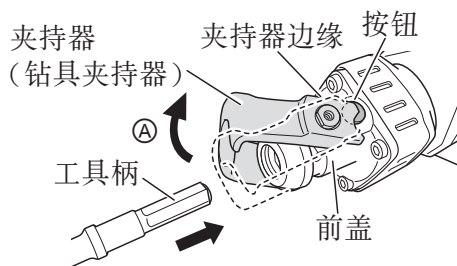
此电动锤钻装有内置电子控制电路，可以调控转数和锤击次数。根据作业内容，例如在易碎材料上钻孔、凿平、定中等，可通过调整转速选择开关来使用此电动锤钻。

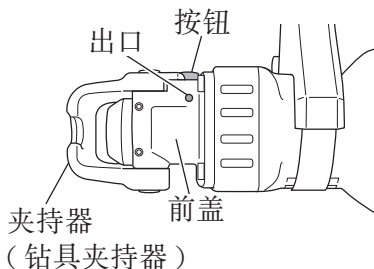

图 21

如表 4 所示，按转速选择开关切换转速。

表 4

显示灯次序				
无负荷速度 (/min)	250	340	420	500
满载锤击率 (/min)	1400	1900	2350	2800

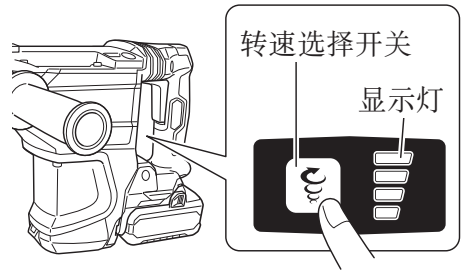
注：

- 只有在电池安装到电动工具且启动一次开关之后，才能调节转速。
- 当电机正在运行时无法通过按转速选择开关更改转速。若要更改速度，请首先将工具关闭。

7. 有关保护功能

本产品具有专门用于保护工具自身及电池的功能。拉动开关时，如果在作业过程中启动了任何保护功能，显示灯将如表 5 所述状态进行闪烁。当启动了任何保护功能后，立即将您的手指从开关上移开，并按照解决方法中所述的指示进行操作。

表 5

显示灯闪烁	原因	解决方法
闪烁 	内部温度已经超出装置指定的温度。 (温度上升保护功能)	关闭设备并让其冷却约 15 分钟至 30 分钟。当温度下降后，按转速选择开关进行复位。
闪烁 	工具上施加了过大压力从而导致工具过负荷。 (过负荷保护功能)	按转速选择器开关进行恢复。尝试避免会对本单元产生过大压力的作业。
闪烁 	传感器信号读取错误。 (控制监控功能)	按转速选择器开关进行恢复。如果此错误持续发生，则需要维修。

注：
如果采取了所有必要步骤排除故障后显示灯还是闪烁，则可能需要进行维修。
如果问题依然存在，则请安排进行维修。

8. 关于剩余电量指示灯

可以按下剩余电池电量指示灯开关点亮指示灯，查看电池的剩余电量。

(图 22, 表 6)

按住剩余电池电量指示灯开关约 3 秒后，指示灯将熄灭。

环境温度和电池状态可能会对剩余电池电量产生轻微的影响，因此，建议您仅将指示灯作为参考。

此外，电动工具或充电器上的剩余电池电量指示灯可能有所不同。



图 22

表 6

指示灯状态	电池剩余电量
	点亮； 电池剩余电量超过 75%
	点亮； 电池剩余电量为 50%—75%
	点亮； 电池剩余电量为 25%—50%
	点亮； 电池剩余电量不到 25%
	闪烁； 电池剩余电量即将耗尽。请尽快对电池进行充电。
	闪烁； 因高温暂停输出从电动工具中取下电池，让电池完全冷却。
	闪烁； 因失败或故障暂停输出。电池可能出现故障，请与经销商联系。

环境温度和电池特性不同，则所显示的电池剩余电量也会有些许不同，以上内容仅供参考。

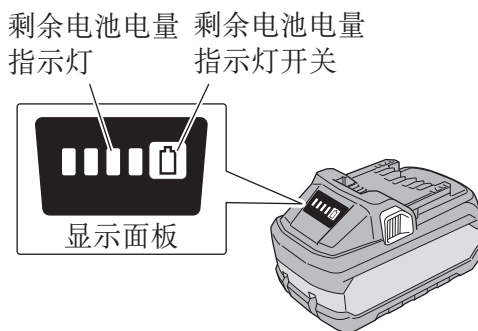
注：
请勿对显示面板施加强烈冲击或将其损坏，否则可能会导致故障。

中文

9. 如何使用 LED 灯

在拉动开关的同时，LED 灯将自动点亮工具的尖端部分。（图 23）

在释放开关后，LED 灯将自动熄灭 10 秒。



图 23

注意！

- 请勿直视光线，将双眼直接暴露于光线中。

如双眼持续暴露于光线中，则双眼会受伤。

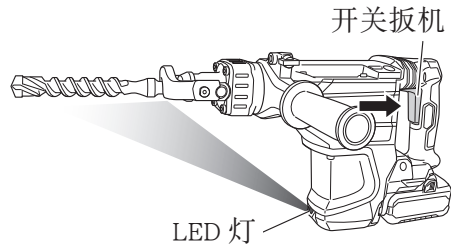
- 使用软布拭去 LED 灯镜头上附着的任何灰尘或污垢，请小心勿划伤镜头。LED 灯镜头上的划痕会导致亮度降低。

使用方法

注意！

为延长使用期限，锂离子电池配备停止输出的保护功能。因此，如果工具过载，马达可能停止。不过，这只是保护功能作用的结果，而不是故障。在此情况下，松开工具的开关，消除造成过载的原因。

1. 钻孔方法（图 24）

- (1) 将钻头尖端放在要钻孔的位置，然后拉动开关扳机。
- (2) 进行作业时，不需要用力按压电动锤钻钻体。只需稍加按压，让钻碎的粉尘徐徐排出即可。



图 24

注意！

尽管本机内装有滑动离合器，但如果钻头碰到钢筋或其他材料时会立即停止转动，这时，机会因反冲力而转动。因此，作业过程中必须握紧手柄和侧柄。

2. 凿开或粉碎方法（图 25）

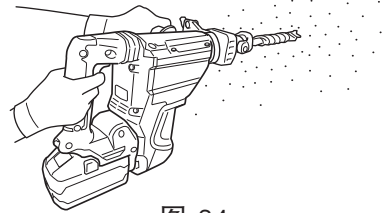
将工具尖端放在要凿开或粉碎的位置，利用电动锤钻自重进行作业。作业时，无需用力推压。



图 25

3. 安装挡块 (图 26)

- (1) 松开翼形螺栓，然后将挡块插入侧柄上的安装孔内。
- (2) 根据孔深调节挡块位置，然后牢牢拧紧翼形螺栓。

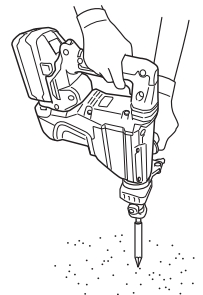

图 26

4. 加热 (图 27)

在寒冷地区，本装置的滑脂润滑系统可能需要加热。使钻头前端触及混凝土表面，打开开关进行加热作业。注意，在听到钻击声后才使用本装置。

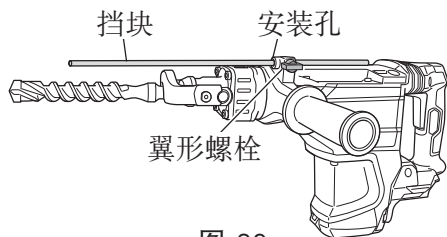

图 27

注意！

在进行加热作业时，请用双手握紧侧柄和钻体以保持安全的夹持力，并小心不要因钻头被卡住而使您的身体倾斜。

钻心的使用方法

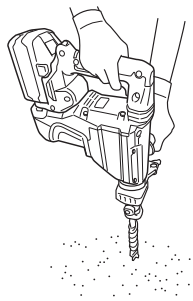
镗穿大孔时，可使用钻心进行作业。此时，必需使用选购件的中央销和钻心轴。

1. 安装

警告！

为避免意外事故，请务必关闭开关并断开电池。

中文

(1) 将钻心安装到钻心轴。(图 28)

润滑钻心轴的螺纹，可使拆解更加容易。

(2) 将钻心轴安装到电动锤钻。(图 29)

(3) 将中央销插入引导盘，一直插到底。

(4) 将引导盘和钻心拼装起来，往左或往右转动引导盘，直到朝下也不掉落。(图 30)



图 28



图 29

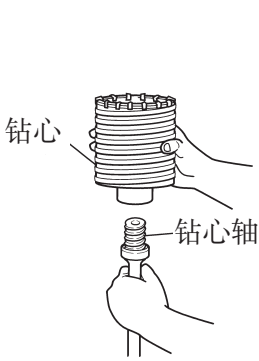

图 30

2. 钻孔方法 (图 31)

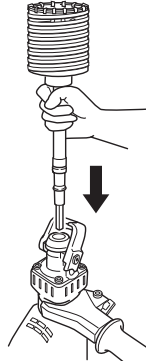
(1) 安装电池。

(2) 中央销里装有弹簧。将其轻轻地笔直推入墙壁或地板。连接钻心尖端的全表面并开始操作。

(3) 钻到大约 5 mm 深度，钻孔位置即可确定。这时候，可从钻心拆下中央销和引导盘。

(4) 过分用力不仅无助于作业，而且还会损坏钻头的刃尖，缩短电动锤钻的寿命。



图 31

警告！

拆下中央销和引导盘时，请关闭开关并断开电池。

3. 拆卸 (图 32)

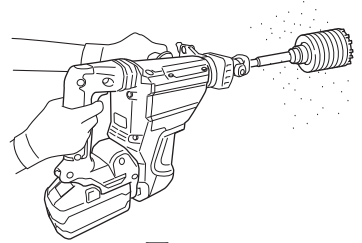
从电动锤钻拆下钻心轴，然后拿稳钻心，用手动锤强力锤击钻心轴头部二至三次，让螺纹部松开，将钻心拆下。



图 32

反作用力控制

本产品拥有反作用力控制(RFC)功能，可减轻机器震颤。

如果工具的刀头突然负载过重，可通过触发滑动离合器或用机器内安装的传感器来停止电机，以此来减轻机身震颤。

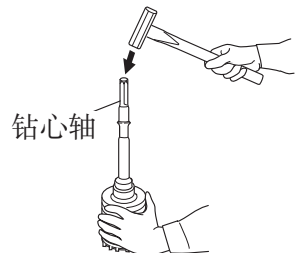
如果电机因控制器检测到负载过重而停止，则拉下开关时，显示灯将变为闪烁状态。此外，松开此开关后，指示灯将继续闪烁约三秒钟。在灯闪烁时电机将保持停止状态。(图 33)

由于 RFC 功能可能未触发或因作业环境和条件而导致性能不足，因此操作时请勿使工具的刀头负载过重并牢牢地握住电动工具。



图 33

● 突然负担过重的可能原因

- ① 钻头陷入材料
 - ② 对钉子、金属或其他硬质物体的作用
 - ③ 涉及撬动或任何过度压力应用的工作
- 另外，包括任何上述原因组合的其他原因

● 当反作用力控制(RFC)启动

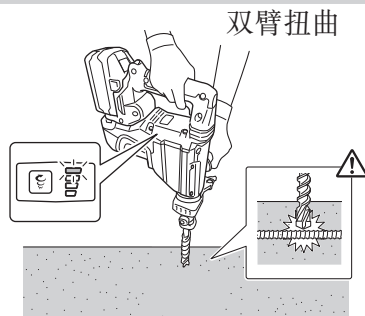
当反作用力控制(RFC)启动并且马达停止时，关闭工具的电源解除过度负担原因后继续操作。

操作上的注意事项

连续作业后须让电动工具休息片刻

(1) 电动工具带有温度保护电路以保护马达。

长时间连续作业可能会导致机器温度升高、触发温度保护电路并自动停止作业。

如果发生这种情况，请让电动工具冷却后再使用。

(2) 请在长时间连续作业后或更换电池后，使使机器静止 15 分钟。如果在更换电池后立刻开始作业，马达和开关等的温度将会升高，结果导致烧毁。

维护和检查

警告！

检查或维护前，请务必关闭开关并取出电池。

1. 检查刀具

由于使用钝刀具会导致电机故障及效率降低，因此在注意到磨损时，需尽快使用新刀具或重新打磨的刀具进行更换。

2. 检查螺钉

要经常检查安装螺钉是否紧固妥善。若发现螺钉松了，应立即重新扭紧。

警告！

使用螺钉松动的电动锤钻会导致危险。

3. 电动机的维护

电动机绕线是电动工具的“心脏部”应仔细检查有无损伤，是否被油液或水沾湿。

4. 更换滑脂

此旋转锤具有完全气密结构以进行防尘。

因此，此电动锤钻可长时间使用而无需更换滑脂。请参阅以下内容了解油脂更换。

○ 滑脂更换时间

购买本产品后，每 6 个月需要更换一次滑脂。更换滑脂时，请联系离您最近的授权服务中心进行更换。

5. 检查端子（工具和电池）

确保端子上没有堆积削屑和灰尘。

在操作前、操作时和操作后需要时常检查。

注意！

请清除端子上的削屑或灰尘。

否则可能导致故障。

6. 清理外部

电动工具沾污时，用干软布或沾肥皂水的布擦拭。切勿使用氯溶液、汽油或稀释剂，以免塑胶部分溶化。

7. 清洁电池安装舱和电池

在钻过混凝土后，如混凝土尘聚积在电池安装舱和电池上，请在使用刀具前，用气枪或干布清理掉聚积的混凝土尘。（图 34）

此外，请在清洁后确保可以顺畅地安装电池或从工具中取出电池。

注意！

如果电池上面覆盖有混凝土灰尘，则使用工具时可能会导致事故，如电池在使用期间掉落等。此外，这可能会导致故障，或致使电池与端子接触不良。



图 34

8. 电力耗尽的电池的处理方法

警告！

请勿将用过的电池乱丢。如果焚烧电池，将引起爆炸。您所购买的产品中包含可充电电池。该电池可回收利用。根据各国家和地区的法令法规，将电力耗尽的电池丢弃到城市垃圾中属于违法行为。请向当地的固体废弃物负责人员咨询具体回收事宜或妥善的处理方法。

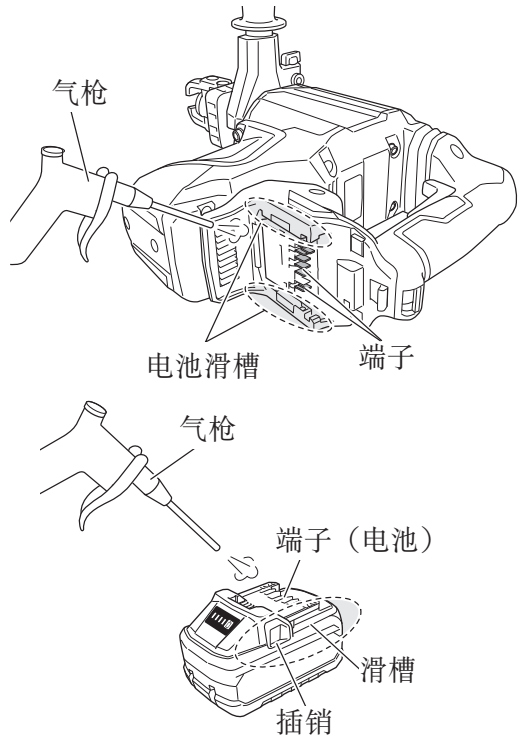
中文

9. 收藏

电动工具应收藏于温度低于 40°C 和小孩拿不到的地方。

注：

存放锂离子电池

在存放前请确保锂离子电池已完全充电。

电池在低电量的状态下长时间存放（3 个月或更长），可能会导致电池性能劣化，使用时间明显减少或无法进行充电。

但是，即使是使用时间明显减少的电池，通过反复充电和使用 2 ~ 5 次，有时也可恢复使用时间。

若反复充电和使用后电池的使用时间仍非常短，请认作为电池已达到了使用寿命并更换新的电池。

10. 维护和维修

由于正常使用带来的磨损，所有的优质电动刀具最终均需要进行维护或部件更换。要确保仅会使用授权的更换部件，全部的维护及维修均必须仅由 HiKOKI 授权的维护中心进行。

注意！

在操作和维修电动工具时，必须遵守贵国制定的安全的有关规则和标准。

关于 HiKOKI 牌无线电动工具的重要通知：

请确保始终使用我们指定的正版电池。如果使用我们指定以外的电池，或对电池进行拆卸和改动（例如拆卸和更换电池组件或其他内部部件），那么我们无法保证我们无线电动工具的安全性和使用性能。

故障排除

如果工具操作不正常，请使用下表中的检查步骤。如果未能解决问题，请向经销商或 HiKOKI 公司授权服务中心咨询。

1. 电动工具

现象	可能的原因	解决办法
工具无法运行	没有剩余电池电量	为电池充电
	电池没有牢固安装	按压电池直到听到咔嚓声
	电池安装槽的端子上以及电池滑槽上积聚了混凝土灰尘。	请用干布清洁积聚的灰尘。
	在开关扳机开启时安装了电池。	请关闭开关扳机，再安装电池。
工具突然停止	工具过度负重	消除过度负重的原因。
	反作用力控制已经启动	请参见“反作用力控制”。
	电池或工具过热	让工具和电池充分冷却。
钻头 - 无法安装 - 掉落	安装部分的形状不匹配	对于六角柄型，请使用直径在指定范围内的钻头。
无法顺利钻孔	电钻已经磨损	替换为新电钻
无法安装电池	请尝试安装该工具指定的其他正版电池。	请安装多电压式电池。

2. 充电器

现象	可能的原因	解决办法
充电指示灯快速闪动紫色，电池未开始充电。	电池未完全插入。	请紧紧插入电池。
	电池端部或电池的连接处有异物。	将异物清除。
充电指示灯闪烁红色，电池未开始充电。	电池未完全插入。	请紧紧插入电池。
	电池过热。	如果继续放置，电池将在温度降低后自动开始充电，但此种情况可能会缩短电池使用寿命。建议将电池放置在通风良好的位置，在充电前避免阳光直射。

现象	可能的原因	解决办法
即使电池完全充电，电池的使用寿命也会逐渐缩短。	电池的使用寿命已耗尽。	请更换新电池。
电池的充电时间较长。	电池、充电器或周围环境的温度过低。	请在室内或温暖的环境中充电。
	充电器的排气孔堵塞，导致其内部部件过热。	请勿堵塞排气孔。
	冷却扇未运转。	请联系 HiKOKI 授权服务中心进行维修。
USB 电源指示灯已熄灭，且 USB 设备已停止充电。	电池容量已变低。	使用有剩余容量的电池进行更换。
		将充电器的电源插头插入电气插座。
即使 USB 设备已完成充电，USB 电源指示灯仍不会熄灭。	USB 电源指示灯亮起绿色，表示可进行 USB 充电。	此非故障。
不清楚 USB 设备的充电状态，或其充电是否完成。	即使充电已完成，USB 电源指示灯仍不熄灭。	检查正在充电的 USB 设备，以确定其充电状态。

现象	可能的原因	解决办法
USB 设备在中途暂停充电。	使用电池作为电源对 USB 设备进行充电时，充电器插入电插座。	这种情况不属于故障。充电器与电源间存在差异时，USB 将暂停充电约 5 秒钟。
	使用电源插座作为电源对 USB 设备进行充电时，电池插入充电器。	
电池和 USB 设备同时充电时，USB 设备将在中途暂停充电。	电池已完全充电。	这种情况不属于故障。检查电池是否已充电完成时，充电器将暂停 USB 充电约 5 秒钟。
电池和 USB 设备同时充电时，USB 设备将无法开始充电。	电池剩余电量已不足。	这种情况不属于故障。电池电量达到一定程度时，USB 将自动开始充电。

选择附件

根据特定作业选择适合的附件。
有关详细信息请联系 HiKOKI 授权服务中心。

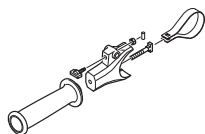

侧柄 (产品编号: 380210)
支架组件 (产品编号: 380209)
把手螺栓 (产品编号: 331247)
箍 (产品编号: 380208)

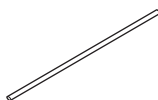

产品编号: 971786
挡块

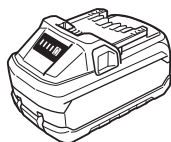

BSL36..18..
电池

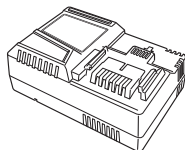

UC18YSL3
(14.4V-18V)
充电器

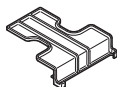

产品编号:
329897
电池盖

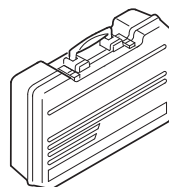

产品编号:
380211
塑料盒

○ 穿孔钻（旋钻+锤击）



(1) 钻头（六角柄）

外径	总长			
	280 mm	400 mm	505 mm	550 mm
	代码号	代码号	代码号	代码号
16 mm	985721	985720	985722	991330
18 mm	—	—	-	991331
19 mm	985724	985723	985725	991332
20 mm	—	—	-	991333
22 mm	985727	985726	985728	991335
25 mm	985730	985729	985731	991336
28 mm	985733	985732	985734	991337
30 mm	—	—	-	991338
32 mm	985736	985735	985737	991339
35 mm	—	—	-	991340
38 mm	985739	985738	985740	991341
40 mm	313322	—	—	—

○ 大径孔钻（旋钻+锤击）



+

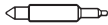

+



+

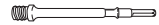

(带导板)

(1) 中间销

(2) 钻头

(3) 钻头轴
(六角柄)

钻心的外径	代码号
50 mm	950475
105 mm	955169

代码号
955165

外径	代码号
50 mm	985380
105 mm	955159

代码号
955163

中文

○ 锚栓工件（用于自钻式锚栓）

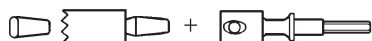

(1) 锚栓附加器（适用于旋钻+锤击）

锚栓尺寸	代码号
W1/4 (20号)	985756
W5/16 (25号)	985757
W3/8 (30号)	985758
W1/2 (40号)	985759
W5/8 (50号)	985760



(3) 扳键

代码号 944574

(2) 锚栓附加器（适用于锤击）

锚栓尺寸	代码号
W3/8 (30号)	981929
W1/2 (40号)	981930
W5/8 (50号)	981931

○ 破碎（锤击）

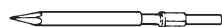

(1) 尖凿

总长	柄型	代码号
280 mm	圆形	981922
	六角形	980752
450 mm	圆形	981923
	六角形	980753

○ 开槽和饰边（锤击）

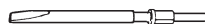

(1) 冷钻

总长	代码号
280 mm	981925
450 mm	981926

○ 切柏油（锤击）

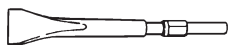

(1) 刀具

总长	宽度	代码号
280 mm	45 mm	981924

○ 挖掘

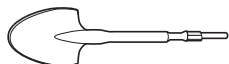

(1) 挖掘

代码号 956126

○ 表面粗加工（锤击）



+

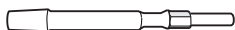

(1) 衬套工具

代码号 955183

(2) 柄

总长	代码号
250 mm	955186

中文

○ 夯实（锤击）

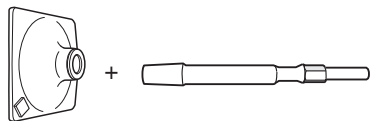

(1) 撞锤

代码号 955181

(2) 柄

全长	代码号
250 mm	955186

○ 洗涤器（排屑用）

代码号 318085

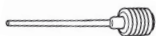

○ 电池（BSL36..18..）

注：

如有规格变动，HiKOKI 概不负责。

CONTENTS

GENERAL POWER TOOL SAFETY WARNINGS	37
CORDLESS ROTARY HAMMER SAFETY WARNINGS	40
ADDITIONAL SAFETY WARNINGS	41
CAUTION ON LITHIUM-ION BATTERY	42
REGARDING LITHIUM-ION BATTERY TRANSPORTATION	44
USB DEVICE CONNECTION PRECAUTIONS (UC18YSL3)	44
SYMBOL.....	45
NAME OF PARTS.....	45
SPECIFICATIONS	46
STANDARD ACCESSORIES	47
APPLICATIONS.....	48
BATTERY REMOVAL/INSTALLATION	48
CHARGING	48
HOW TO RECHARGE USB DEVICE	51
PRIOR TO OPERATION.....	53
HOW TO USE.....	58
HOW TO USE THE CORE BIT	59
REACTIVE FORCE CONTROL	60
OPERATIONAL CAUTIONS.....	61
MAINTENANCE AND INSPECTION	61
TROUBLESHOOTING.....	64
SELECTING ACCESSORIES.....	67

GENERAL POWER TOOL SAFETY WARNINGS

WARNING

Read all safety warnings, instructions, illustrations and specifications provided with this power tool.

Failure to follow all instructions listed below may result in electric shock, fire and/or serious injury.

Save all warnings and instructions for future reference.

The term “power tool” in the warnings refers to your mains-operated (corded) power tool or battery-operated (cordless) power tool.

- 1) **Work area safety**
 - a) **Keep work area clean and well lit.**
Cluttered or dark areas invite accidents.
 - b) **Do not operate power tools in explosive atmospheres, such as in the presence of flammable liquids, gases or dust.**
Power tools create sparks which may ignite the dust or fumes.
 - c) **Keep children and bystanders away while operating a power tool.**
Distractions can cause you to lose control.

English

2) Electrical safety

- a) **Power tool plugs must match the outlet.**
Never modify the plug in any way.
Do not use any adapter plugs with earthed (grounded) power tools.
Unmodified plugs and matching outlets will reduce risk of electric shock.
- b) **Avoid body contact with earthed or grounded surfaces, such as pipes, radiators, ranges and refrigerators.**
There is an increased risk of electric shock if your body is earthed or grounded.
- c) **Do not expose power tools to rain or wet conditions.**
Water entering a power tool will increase the risk of electric shock.
- d) **Do not abuse the cord. Never use the cord for carrying, pulling or unplugging the power tool.**
Keep cord away from heat, oil, sharp edges or moving parts.
Damaged or entangled cords increase the risk of electric shock.
- e) **When operating a power tool outdoors, use an extension cord suitable for outdoor use.**
Use of a cord suitable for outdoor use reduces the risk of electric shock.
- f) **If operating a power tool in a damp location is unavoidable, use a residual current device (RCD) protected supply.**
Use of an RCD reduces the risk of electric shock.

3) Personal safety

- a) **Stay alert, watch what you are doing and use common sense when operating a power tool.**
Do not use a power tool while you are tired or under the influence of drugs, alcohol or medication.
A moment of inattention while operating power tools may result in serious personal injury.
- b) **Use personal protective equipment. Always wear eye protection.**
Protective equipment such as a dust mask, non-skid safety shoes, hard hat or hearing protection used for appropriate conditions will reduce personal injuries.
- c) **Prevent unintentional starting. Ensure the switch is in the off-position before connecting to power source and/or battery pack, picking up or carrying the tool.**
Carrying power tools with your finger on the switch or energising power tools that have the switch on invites accidents.
- d) **Remove any adjusting key or wrench before turning the power tool on.**
A wrench or a key left attached to a rotating part of the power tool may result in personal injury.
- e) **Do not overreach. Keep proper footing and balance at all times.**
This enables better control of the power tool in unexpected situations.
- f) **Dress properly. Do not wear loose clothing or jewellery. Keep your hair, clothing and gloves away from moving parts.**
Loose clothes, jewellery or long hair can be caught in moving parts.

- g) **If devices are provided for the connection of dust extraction and collection facilities, ensure these are connected and properly used.**

Use of dust collection can reduce dust-related hazards.

- h) **Do not let familiarity gained from frequent use of tools allow you to become complacent and ignore tool safety principles.**

A careless action can cause severe injury within a fraction of a second.

4) **Power tool use and care**

- a) **Do not force the power tool. Use the correct power tool for your application.**

The correct power tool will do the job better and safer at the rate for which it was designed.

- b) **Do not use the power tool if the switch does not turn it on and off.**

Any power tool that cannot be controlled with the switch is dangerous and must be repaired.

- c) **Disconnect the plug from the power source and/or remove the battery pack, if detachable, from the power tool before making any adjustments, changing accessories, or storing power tools.**

Such preventive safety measures reduce the risk of starting the power tool accidentally.

- d) **Store idle power tools out of the reach of children and do not allow persons unfamiliar with the power tool or these instructions to operate the power tool.**

Power tools are dangerous in the hands of untrained users.

- e) **Maintain power tools and accessories. Check for misalignment or binding of moving parts, breakage of parts and any other condition that may affect the power tool's operation.**

If damaged, have the power tool repaired before use.

Many accidents are caused by poorly maintained power tools.

- f) **Keep cutting tools sharp and clean.**

Properly maintained cutting tools with sharp cutting edges are less likely to bind and are easier to control.

- g) **Use the power tool, accessories and tool bits etc. in accordance with these instructions, taking into account the working conditions and the work to be performed.**

Use of the power tool for operations different from those intended could result in a hazardous situation.

- h) **Keep handles and grasping surfaces dry, clean and free from oil and grease.**

Slippery handles and grasping surfaces do not allow for safe handling and control of the tool in unexpected situations.

5) **Battery tool use and care**

- a) **Recharge only with the charger specified by the manufacturer.**

A charger that is suitable for one type of battery pack may create a risk of fire when used with another battery pack.

- b) **Use power tools only with specifically designated battery packs.**

Use of any other battery packs may create a risk of injury and fire.

English

- c) **When battery pack is not in use, keep it away from other metal objects, like paper clips, coins, keys, nails, screws or other small metal objects, that can make a connection from one terminal to another.**
Shorting the battery terminals together may cause burns or a fire.
- d) **Under abusive conditions, liquid may be ejected from the battery; avoid contact. If contact accidentally occurs, flush with water. If liquid contacts eyes, additionally seek medical help.**
Liquid ejected from the battery may cause irritation or burns.
- e) **Do not use a battery pack or tool that is damaged or modified.**
Damaged or modified batteries may exhibit unpredictable behaviour resulting in fire, explosion or risk of injury.
- f) **Do not expose a battery pack or tool to fire or excessive temperature.**
Exposure to fire or temperature above 130 °C may cause explosion.
- g) **Follow all charging instructions and do not charge the battery pack or tool outside the temperature range specified in the instructions.**
Charging improperly or at temperatures outside the specified range may damage the battery and increase the risk of fire.

6) Service

- a) **Have your power tool serviced by a qualified repair person using only identical replacement parts.**
This will ensure that the safety of the power tool is maintained.
- b) **Never service damaged battery packs.**
Service of battery packs should only be performed by the manufacturer or authorized service providers.

CAUTION

Keep children and infirm persons away.

When not in use, tools should be stored out of reach of children and infirm persons.

CORDLESS ROTARY HAMMER SAFETY WARNINGS

Safety instructions for all operations

1. **Wear ear protectors.**
Exposure to noise can cause hearing loss.
2. **Use the auxiliary handle(s), if supplied with the tool.**
Loss of control can cause personal injury.
3. **Hold the power tool by insulated gripping surfaces, when performing an operation where the cutting accessory may contact hidden wiring.**
Cutting accessory contacting a "live" wire may make exposed metal parts of the power tool "live" and could give the operator an electric shock.

Safety instructions when using long drill bits with rotary hammers

4. **Always start drilling at low speed and with the bit tip in contact with the workpiece.**
At higher speeds, the bit is likely to bend if allowed to rotate freely without contacting the workpiece, resulting in personal injury.

5. **Apply pressure only in direct line with the bit and do not apply excessive pressure.**
Bits can bend causing breakage or loss of control, resulting in personal injury.

ADDITIONAL SAFETY WARNINGS

1. **Do not allow foreign matter to enter the hole for connecting the rechargeable battery.**
2. **Never disassemble the rechargeable battery and charger.**
3. **Never short-circuit the rechargeable battery. Shortcircuiting the battery will cause a great electric current and overheat. It results in burn or damage to the battery.**
4. **Do not dispose of the battery in fire. If the battery is burnt, it may explode.**
5. **When using this unit continuously, the unit may overheat, leading to damage in the motor and switch. Please leave it without using it for approximately 15 minutes.**
6. **Do not insert object into the air ventilation slots of the charger. Inserting metal objects or inflammables into the charger air ventilation slots will result in electrical shock hazard or damaged charger.**
7. **Bring the battery to the shop from which it was purchased as soon as the post-charging battery life becomes too short for practical use. Do not dispose of the exhausted battery.**
8. **Before starting to break, chip or drill into a wall, floor or ceiling, thoroughly confirm that such items as electric cables or conduits are not buried inside.**
9. **Ensure that the power switch is in the OFF position. If the battery is installed while the power switch is in the ON position, the power tool will start operating immediately, which could cause a serious accident.**
10. **Do not touch the bit during or immediately after operation.**
The bit becomes very hot during operation and could cause serious burns.
11. **Always hold the body handle and side handle of the power tool firmly. Otherwise the counterforce produced may result in inaccurate and even dangerous operation.**
12. **Wear a dust mask**
Do not inhale the harmful dusts generated in drilling or chiseling operation. The dust can endanger the health of yourself and bystanders.
13. **Make sure that the battery is installed firmly. If it is at all loose it could come off and cause an accident.**
14. **To prevent accidents, make sure to turn the switch off and pull out the battery before changing accessories, storing, carrying or when not using the tools.**
15. **Mounting the tool**
 - **To prevent accidents, make sure to turn the switch off and pull out the battery.**
 - **When using tools such as bull points, drill bits, etc., make sure to use the genuine parts designated by our company.**
 - **Clean the shank portion of the drill bit. Then smear the shank portion with the grease or machine oil.**
 - **Check the latching by pulling on the drill bit.**

English

16. Rotation + hammering

When the drill bit touches construction iron bar, the bit will stop immediately and the rotary hammer will react to revolve. Therefore firmly tighten the side handle, hold the body handle and side handles.

17. Do not use the product if the tool or the battery terminals (battery mount) are deformed.

Installing the battery could cause a short circuit that could result in smoke emission or ignition.

18. Keep the tool's terminals (battery mount) free of swarf and dust.

○ Prior to use, make sure that swarf and dust have not collected in the area of the terminals.

○ During use, try to avoid swarf or dust on the tool from falling on the battery.

○ When suspending operation or after use, do not leave the tool in an area where it may be exposed to falling swarf or dust.

Doing so could cause a short circuit that could result in smoke emission or ignition.

19. Do not look directly into the light. Such actions could result in eye injury.

Wipe off any dirt or grime attached to the lens of the LED light with a soft cloth, being careful not to scratch the lens. Scratches on the lens of the LED light can result in decreased brightness.

20. Always use the tool and battery at temperatures between -5°C and 40°C.

21. Always charge the battery at an ambient temperature of 0–40°C.

22. Make sure to securely hold the tool as shown in Fig. 1 during operation.

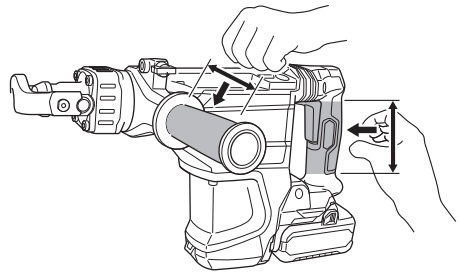

Fig. 1

CAUTION ON LITHIUM-ION BATTERY

To extend the lifetime, the lithium-ion battery equips with the protection function to stop the output.

In the cases of 1 to 3 described below, when using this product, even if you are pulling the switch, the motor may stop. This is not the trouble but the result of protection function.

1. When the battery power remaining runs out, the motor stops.

In such case, charge it up immediately.

2. If the tool is overloaded, the motor may stop. In this case, release the switch of tool and eliminate causes of overloading. After that, you can use it again.

3. If the battery is overheated under overload work, the battery power may stop.

In this case, stop using the battery and let the battery cool. After that, you can use it again.

Furthermore, please heed the following warning and caution.

WARNING

In order to prevent any battery leakage, heat generation, smoke emission, explosion and ignition beforehand, please be sure to heed the following precautions.

1. Make sure that swarf and dust do not collect on the battery.
 - During work make sure that swarf and dust do not fall on the battery.
 - Make sure that any swarf and dust falling on the power tool during work do not collect on the battery.
 - Do not store an unused battery in a location exposed to swarf and dust.
 - Before storing a battery, remove any swarf and dust that may adhere to it and do not store it together with metal parts (screws, nails, etc.).
2. Do not pierce battery with a sharp object such as a nail, strike with a hammer, step on, throw or subject the battery to severe physical shock.
3. Do not use an apparently damaged or deformed battery.
4. Do not use the battery in reverse polarity.
5. Do not connect directly to an electrical outlets or car cigarette lighter sockets.
6. Do not use the battery for a purpose other than those specified.
7. If the battery charging fails to complete even when a specified recharging time has elapsed, immediately stop further recharging.
8. Do not put or subject the battery to high temperatures or high pressure such as into a microwave oven, dryer, or high pressure container.
9. Keep away from fire immediately when leakage or foul odor are detected.
10. Do not use in a location where strong static electricity generates.
11. If there is battery leakage, foul odor, heat generated, discolored or deformed, or in any way appears abnormal during use, recharging or storage, immediately remove it from the equipment or battery charger, and stop use.
12. Do not immerse the battery or allow any fluids to flow inside. Conductive liquid ingress, such as water, can cause damage resulting in fire or explosion. Store your battery in a cool, dry place, away from combustible and flammable items. Corrosive gas atmospheres must be avoided.

CAUTION

1. If liquid leaking from the battery gets into your eyes, do not rub your eyes and wash them well with fresh clean water such as tap water and contact a doctor immediately.
If left untreated, the liquid may cause eye-problems.
2. If liquid leaks onto your skin or clothes, wash well with clean water such as tap water immediately.
There is a possibility that this can cause skin irritation.
3. If you find rust, foul odor, overheating, discolor, deformation, and/or other irregularities when using the battery for the first time, do not use and return it to your supplier or vendor.

English

WARNING

If an electrically conductive foreign object enters the terminals of the lithium ion battery, a short-circuit may occur resulting in the risk of fire. Please observe the following matters when storing the battery.

- Do not place electrically conductive cuttings, nails, steel wire, copper wire or other wire in the storage case.
- Either install the battery in the power tool or store by securely pressing into the battery cover until the ventilation holes are concealed to prevent short-circuits (See Fig. 2).

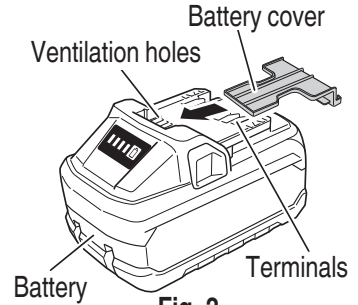

Fig. 2

REGARDING LITHIUM-ION BATTERY TRANSPORTATION

When transporting a lithium-ion battery, please observe the following precautions.

WARNING

Notify the transporting company that a package contains a lithium-ion battery, inform the company of its power output and follow the instructions of the transportation company when arranging transport.

- Lithium-ion batteries that exceed a power output of 100 Wh are considered to be in the freight classification of Dangerous Goods and will require special application procedures.
- For transportation abroad, you must comply with international law and the rules and regulations of the destination country.
- If the BSL36B18X is installed in the power tool, the power output will exceed 100 Wh and the unit will be classified as Dangerous Goods for freight classification.

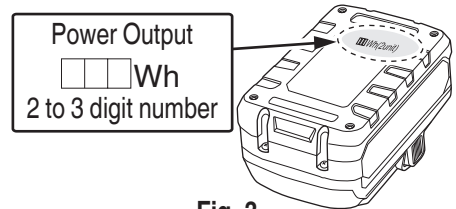

Fig. 3

USB DEVICE CONNECTION PRECAUTIONS (UC18YSL3)



When an unexpected problem occurs, the data in a USB device connected to this product may be corrupted or lost. Always make sure to back up any data contained in the USB device prior to use with this product.

Please be aware that our company accepts absolutely no responsibility for any data stored in a USB device that is corrupted or lost, nor for any damage that may occur to a connected device.

SYMBOL

WARNING

The following show symbols used for the machine. Be sure that you understand their meaning before use.

	To reduce the risk of injury, user must read instruction manual.	n_0	No-load speed
	Direct current	/min	Oscillation per minute
V	Rated voltage		Warning

NAME OF PARTS

1. Power Tool

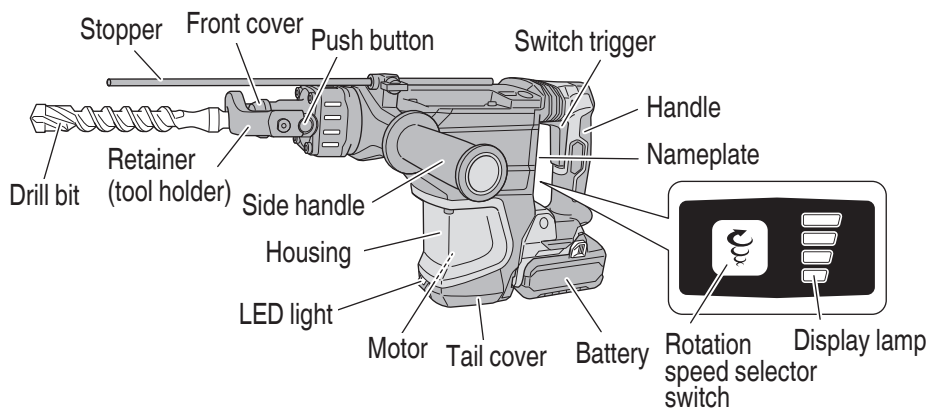
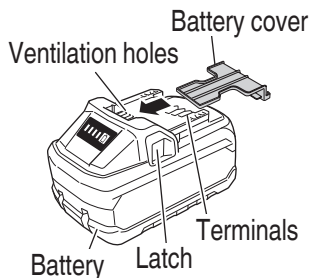

Fig. 4

2. Battery



<BSL36B18X>

Fig. 5

3. Battery Charger

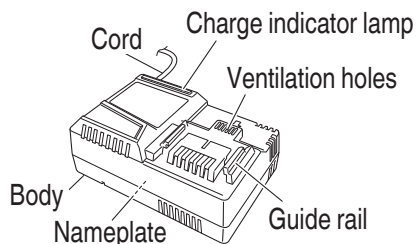

<UC18YSL3>

Fig. 6

SPECIFICATIONS

POWER TOOL

Model	DH3640DB	
Voltage	36 V	
No-load speed	250–500 /min	
Full-load impact rate	1400–2800 /min	
Capacity	Drill bit	40 mm
	Core bit	105 mm
Battery*	Model	BSL36B18X: Li-ion 36 V / 18 V (4.0 Ah / 8.0 Ah 10 cells)
Weight	7.2 kg (BSL36B18X: attached)	

* Existing batteries (BSL3660/3626X/3626/3625/3620, BSL18xx and BSL14xx series) cannot be used with this tool.



CHARGER

Model	UC18YSL3
Charging voltage	14.4–18 V
Weight	0.6 kg

STANDARD ACCESSORIES

In addition to the main unit (1 unit), the package contains the accessories listed in the below.

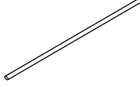
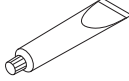
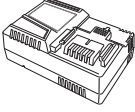
Table 1

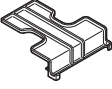
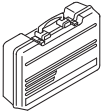
		DH3640DB
Side Handle		1
Stopper		1
Grease		1
Charger (UC18YSL3)		1
Battery (BSL36B18X)		2
Battery cover		2
Case (Molded plastic)		1

APPLICATIONS

- Drilling anchor holes
- Drilling holes in concrete
- Crushing concrete, chipping, digging, and squaring
(Some applications need optional accessories)

BATTERY REMOVAL/INSTALLATION

1. **Battery installation**
Align the battery with the groove in tool handle and slip it into place.
Always insert it all the way until it locks in place with a little click. If not, it may accidentally fall out of the tool, causing injury to you or someone around you (see **Fig. 7**).

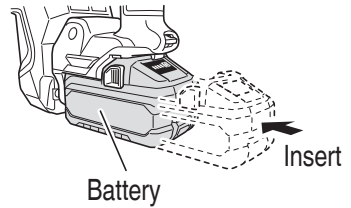

Fig. 7

2. **Battery removal**
Lower the stopper lever to detach the lock. Press the latches on both sides and slide out the battery (**Fig. 8**).

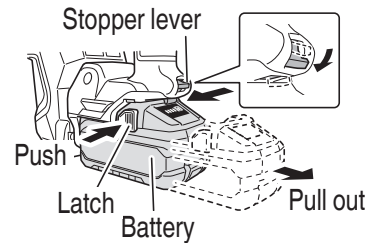

Fig. 8

CAUTION

Never short-circuit the battery.

CHARGING

Before using the power tool, charge the battery as follows.

1. **Connect the charger's power cord to the receptacle.**
When connecting the plug of the charger to a receptacle, the charge indicator lamp will blink in red (At 1- second intervals).
2. **Insert the battery into the charger.**
Firmly insert the battery into the charger as shown in **Fig. 9**.

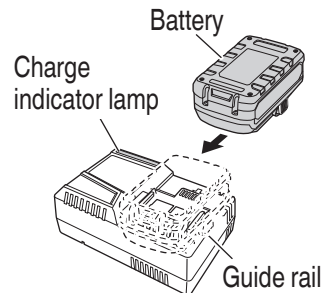

Fig. 9







3. Charging

When inserting a battery in the charger, the charge indicator lamp will blink in blue.
 When the battery becomes fully recharged, the charge indicator lamp will light up in green.
 (See **Table 2**)

(1) Charge indicator lamp indication

The indications of the charge indicator lamp will be as shown in **Table 2**, according to the condition of the charger or the rechargeable battery.

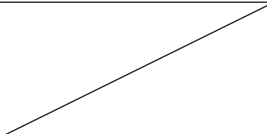
Table 2

Indications of the charge indicator lamp				
Charge indicator lamp (RED / BLUE / GREEN / PURPLE)	Before charging	Blinks (RED)	Lights for 0.5 seconds. Does not light for 0.5 seconds. (off for 0.5 seconds) 	Plugged into power source
	While charging	Blinks (BLUE)	Lights for 0.5 seconds. Does not light for 1 second. (off for 1 second) 	Battery capacity at less than 50%
		Blinks (BLUE)	Lights for 1 second. Does not light for 0.5 seconds. (off for 0.5 seconds) 	Battery capacity at less than 80%
		Lights (BLUE)	Lights continuously 	Battery capacity at more than 80%
	Charging complete	Lights (GREEN)	Lights continuously  (Continuous buzzer sound: about 6 seconds)	
	Overheat standby	Blinks (RED)	Lights for 0.3 seconds. Does not light for 0.3 seconds. (off for 0.3 seconds) 	Battery overheated. Unable to charge. (Charging will commence when battery cools)
	Charging impossible	Flickers (PURPLE)	Lights for 0.1 seconds. Does not light for 0.1 seconds. (off for 0.1 seconds)  (Intermittent buzzer sound: about 2 seconds)	Malfunction in the battery or the charger

English

- (2) Regarding the temperatures and charging time of the rechargeable battery
The temperatures and charging time will become as shown in **Table 3**.

Table 3

Charger		UC18YSL3					
Battery	Type of battery	Li-ion					
	Temperatures at which the battery can be recharged	-10°C–50°C					
	Charging voltage	V	14.4		18		
	Charging time, approx. (At 20°C)	min	BSL14xx series		BSL18xx series		Multi volt series
			(4 cells)	(8 cells)	(5 cells)	(10 cells)	(10 cells)
		BSL1415S: 15 BSL1415 : 15 BSL1415X: 15 BSL1420 : 20 BSL1425 : 25 BSL1430C: 30	BSL1430 : 20 BSL1440 : 26 BSL1450 : 32 BSL1460 : 38	BSL1815S: 15 BSL1815 : 15 BSL1815X: 15 BSL1820 : 20 BSL1825 : 25 BSL1830C: 30 BSL1850C: 32	BSL1830 : 20 BSL1840 : 26 BSL1850 : 32 BSL1860 : 38	BSL36A18 : 32 BSL36A18X: 32 BSL36B18 : 52 BSL36B18X: 52	
USB	Charging voltage	V	5				
	Charging current	A	2				

NOTE

The recharging time may vary according to the ambient temperature and power source voltage.

4. Disconnect the charger's power cord from the receptacle.
5. Hold the charger firmly and pull out the battery.

NOTE

Be sure to pull out the battery from the charger after use, and then keep it.

Regarding electric discharge in case of new batteries, etc.

As the internal chemical substance of new batteries and batteries that have not been used for an extended period is not activated, the electric discharge might be low when using them the first and second time. This is a temporary phenomenon, and normal time required for recharging will be restored by recharging the batteries 2–3 times.

How to make the batteries perform longer.

- (1) Recharge the batteries before they become completely exhausted.
When you feel that the power of the tool becomes weaker, stop using the tool and recharge its battery. If you continue to use the tool and exhaust the electric current, the battery may be damaged and its life will become shorter.
- (2) Avoid recharging at high temperatures.
A rechargeable battery will be hot immediately after use. If such a battery is recharged immediately after use, its internal chemical substance will deteriorate, and the battery life will be shortened. Leave the battery and recharge it after it has cooled for a while.

CAUTION

- **If the battery is charged while it is heated because it has been left for a long time in a location subject to direct sunlight or because the battery has just been used, the charge indicator lamp of the charger lights for 0.3 seconds, does not light for 0.3 seconds (off for 0.3 seconds). In such a case, first let the battery cool, then start charging.**
- **When the charge indicator lamp flickers (at 0.2-second intervals), check for and take out any foreign objects in the charger's battery connector. If there are no foreign objects, it is probable that the battery or charger is malfunctioning. Take it to your authorized Service Center.**
- **Since the built-in micro computer takes about 3 seconds to confirm that the battery being charged with UC18YSL3 is taken out, wait for a minimum of 3 seconds before reinserting it to continue charging. If the battery is reinserted within 3 seconds, the battery may not be properly charged.**

HOW TO RECHARGE USB DEVICE

WARNING

- **Prior to use, check the connecting USB cable for any defect or damage. Using a defective or damaged USB cable can cause smoke emission or ignition.**
- **When the product is not being used, cover the USB port with the rubber cover. Buildup of dust etc. in the USB port can cause smoke emission or ignition.**

NOTE

- There may be an occasional pause during USB recharging.
- When a USB device is not being charged, remove the USB device from the charger. Failure to do so may not only reduce the battery life of a USB device, but may also result in unexpected accidents.
- It may not be possible to charge some USB devices, depending on the type of device.

English

- (1) Select a charging method
 - Charging a USB device from a electrical outlet. (**Fig. 10-a**)
 - Charging a USB device and battery from a electrical outlet. (**Fig. 10-b**)

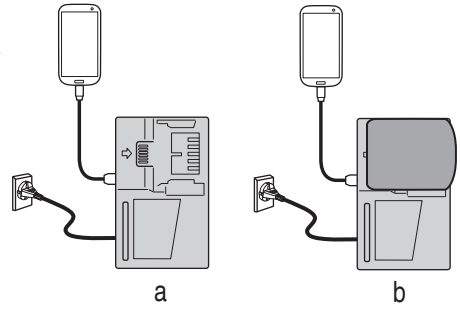

Fig. 10

- (2) Connect the USB cable. (**Fig. 11**)
Pull back the rubber cover and firmly plug in a commercially available USB cable (appropriate to the device being charged) into the USB port.

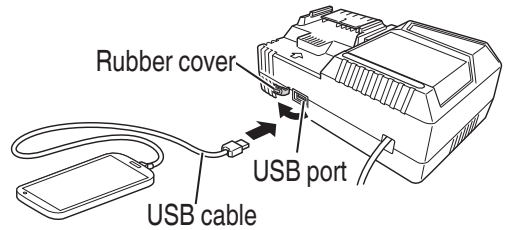

Fig. 11

- (3) When charging is completed
 - To verify charge status, check the USB device.
 - Unplug the power cord from the electrical outlet. (**Fig. 12**)
 - Place the rubber cover over the USB port.

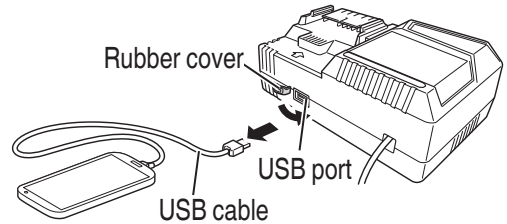

Fig. 12

PRIOR TO OPERATION

WARNING

To prevent accidents, make sure to turn the switch off and disconnect the battery when the drill bits and other various parts are installed or removed. The power switch should also be turned off during a work break and after work.

1. Power switch

Ensure that the power switch is in the OFF position. If the battery is inserted while the power switch is in the ON position, the power tool will start operating immediately, which could cause a serious accident.

2. Confirming condition of the environment:

Confirm that the work site is placed under appropriate conditions conforming to prescribed precautions.

3. Installing the Side Handle

(1) Turn the side handle to dismantle. (Fig. 13)

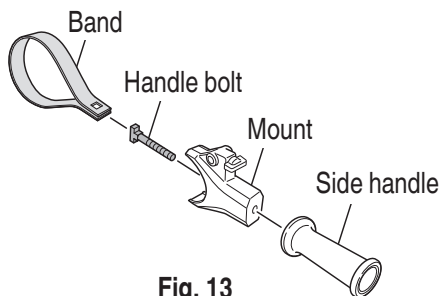

Fig. 13

(2) Place the band over the band attachment area and fit the band's two holes onto the "T" portion of the handle bolt. (Fig. 14, 15)

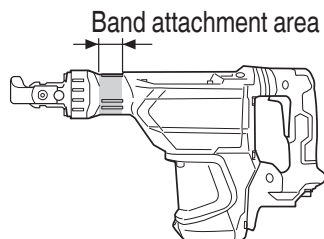

Fig. 14

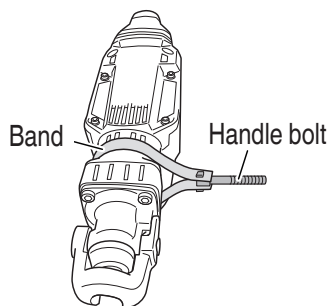

Fig. 15

English

- (3) As you hold the band to make sure the handle bolt won't come loose, insert the handle bolt into the mount. (Fig. 16)

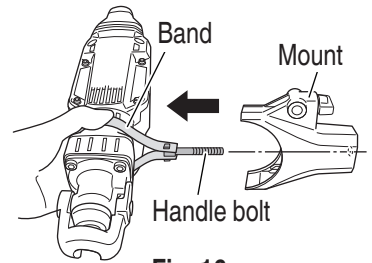

Fig. 16

- (4) Adjusting the band to a position that is suitable for the task, turn the side handle to fasten the band. Make sure that the band is securely fastened. (Fig. 17)

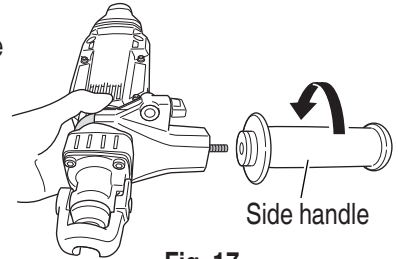

Fig. 17

4. How to install tool

CAUTION

For tools such as a drill bit and a bull point, use only HiKOKI genuine parts.

- (1) Clean, then smear the tool shank with the grease provided in the tube (Fig. 18).
- (2) Press the push button, slightly lift the tool retainer in the direction of arrow (A) as shown in Fig. 19 to hook the tool retainer edge with the push button and engage the push button.
- (3) Release your finger from the push button and further lift the tool retainer in the direction of arrow (A).

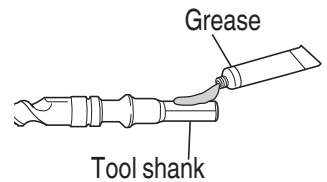

Fig. 18

NOTE

First time when the tool retainer is lifted, remove your finger from the push button. If the push button is kept pressed, the edge of the tool retainer comes in contact with your finger and the tool retainer cannot be lifted.

- (4) Fully insert the tool shank into the hexagonal hole in the front cover.
- (5) Return the tool retainer to secure the tool.
- (6) Pull the tool to make sure it is locked completely.

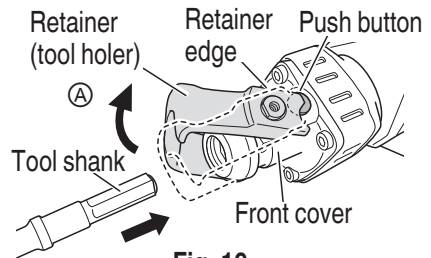
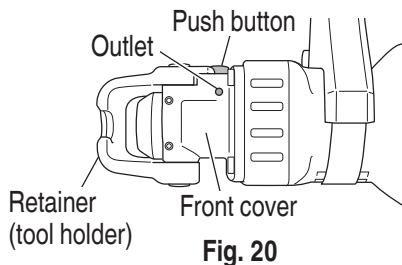

Fig. 19

NOTE

Remove in the reverse order of installation.

5. When the push button does not operate smoothly, please remove dirt from the inside through the outlet using a wire, etc. Then lubricate lubricating oil and push the push button several times to make it operate smoothly. (Fig. 20)



6. Regulating the number of rotations and hammering (Fig. 21)
 This Rotary Hammer is equipped with a built-in electronic control circuit that can adjust and regulate the number of rotations and times of hammering. This Rotary Hammer can be used by adjusting the rotation speed selector switch, depending upon the contents of operation, such as boring holes in fragile materials, chipping, centering, etc.

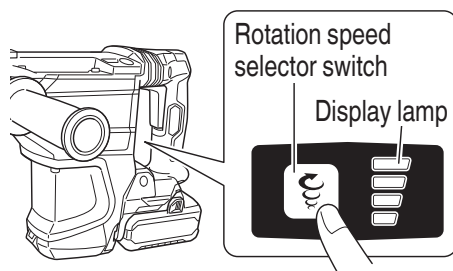

Pressing the rotation speed selector switch switches rotation speeds as shown in **Table 4**.

Table 4

Display lamp sequence				
No-load speed (/min)	250	340	420	500
Full-load impact rate (/min)	1400	1900	2350	2800

NOTE



- Rotation speed cannot be adjusted until a battery is installed to the power tool and the switch has been triggered once.
- The rotation speed cannot be changed by pressing the rotation speed selector switch while the motor is rotating. To change speeds, switch off the tool first.

English

7. About the protection function

This product features functions that are designed to protect the tool itself as well as the battery. While the switch is pulled, if any of the safeguard functions are triggered during operation, the display lamp will blink as described in **Table 5**. When any of the safeguard functions are triggered, immediately remove your finger from the switch and follow the instructions described under corrective action.

Table 5

Display lamp flashing	Cause	Solution
Flash 	Internal temperature has risen beyond the unit's specified temperature. (Temperature increase protection function)	Turn off the unit and allow it to cool down for about 15 to 30 minutes. When the temperature goes down, press the rotation speed selector switch to recover.
Flash 	Excessive pressure applied to the tool has resulted in an overload. (Overload protection function)	Press the rotation speed selector switch to recover. Try to avoid tasks that will apply excess pressure to the unit.
Flash 	Sensor signal read error. (Control monitoring function)	Press the rotation speed selector switch to recover. Repair may be required if this error continuously occurs.

NOTE

Repair may be required if the display lamp continues to flash after taking all necessary steps to correct the problem. If the problem persists, please arrange for repairs.

8. About remaining battery indicator

You can check the battery's remaining capacity by pressing the remaining battery indicator switch to light the indicator lamp. (**Fig. 22, Table 6**) The indicator will shut off approximately 3 seconds after the remaining battery indicator switch is pressed.

It is best to use the remaining battery indicator as a guide since there are slight differences such as ambient temperature and the condition of the battery.

Also, the remaining battery indicator may vary from those equipped to a tool or charger.

Remaining battery indicator lamp Remaining battery indicator switch

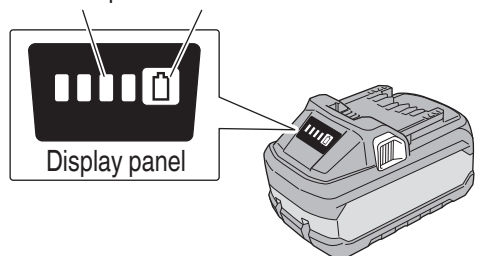





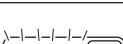
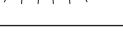

Fig. 22

Table 6

State of lamp	Battery Remaining Power
	Lights ; The battery remaining power is over 75%.
	Lights ; The battery remaining power is 50%–75%.
	Lights ; The battery remaining power is 25%–50%.
	Lights ; The battery remaining power is less than 25%.
	Blinks ; The battery remaining power is nearly empty. Recharge the battery soonest possible.
	Blinks ; Output suspended due to high temperature. Remove the battery from the tool and allow it to fully cool down.
	Blinks ; Output suspended due to failure or malfunction. The problem may be the battery so please contact your dealer.

As the remaining battery indicator shows somewhat differently depending on ambient temperature and battery characteristics, read it as a reference.

NOTE

Do not give a strong shock to the display panel or break it. It may lead to a trouble.

9. How to use the LED light

While the switch is pulled, the LED light will automatically light up the tip portion of the tool. (Fig. 23)

The LED light will automatically turn off 10 seconds after the switch is released.

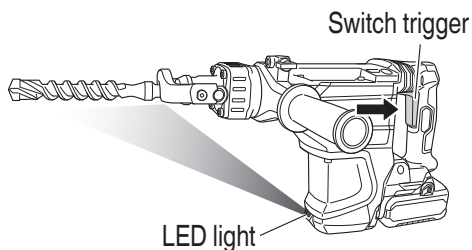

Fig. 23

CAUTION

- Do not expose directly your eye to the light by looking into the light.
If your eye is continuously exposed to the light, your eye will be hurt.
- Wipe off any dirt or grime attached to the lens of the LED light with a soft cloth, being careful not to scratch the lens.
Scratches on the lens of the LED light can result in decreased brightness.

HOW TO USE

CAUTION

To extend the lifetime, the lithium-ion battery equips with the protection function to stop the output. Therefore, if the tool is overloaded, the motor may stop. However, this is not the trouble but the result of protection function. In this case, release the switch of tool and eliminate the causes of overloading.

1. How to drill holes (Fig. 24)
 - (1) Pull the switch trigger after applying the drill bit tip to the drilling position.
 - (2) It is unnecessary to forcibly press the Rotary Hammer main body. It is sufficient to slightly press the rotary hammer to an extent that chips are freely discharged.

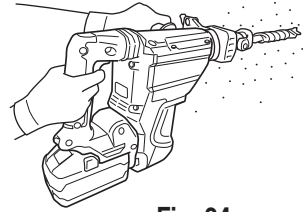

Fig. 24

CAUTION

Although this machine is equipped with a slip clutch, if the drill bit becomes bound in concrete or other material, the resultant stoppage of the drill bit could cause the machine body to turn in reaction. Ensure that the main handle and side handle are gripped firmly during operation.

2. How to chisel or demolish (Fig. 25)

By applying the tool tip to the chiseling or demolishing position, operate the rotary hammer by utilizing its own weight. Forcible pressing or thrusting is unnecessary.

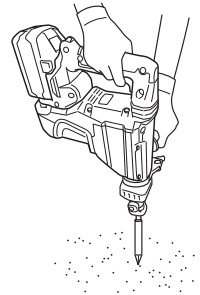

Fig. 25

3. Install the stopper (Fig. 26)
 - (1) Loosen the wing bolt, and insert the stopper into the mounting hole on the side handle.
 - (2) Adjust the stopper position according to the depth of the hole and tighten the wing bolt securely.

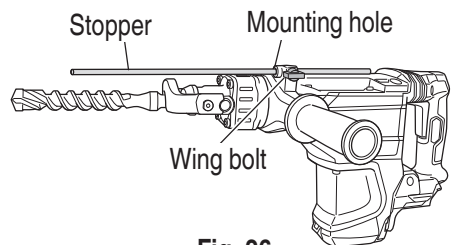

Fig. 26

4. Warming up (Fig. 27)

The grease lubrication system in this unit may require warming up in cold regions.

Position the end of the bit so makes contact with the concrete, turn on the switch and perform the warming up operation. Make sure that a hitting sound is produced and then use the unit.

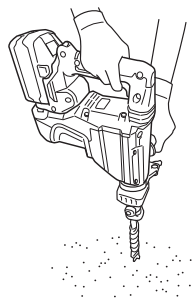

Fig. 27

CAUTION

When the warming up operation is performed, hold the side handle and the main body securely with both hands to maintain a secure grip and be careful not to twist your body by the jammed drill bit.

HOW TO USE THE CORE BIT

When boring penetrating large hole use the core bit. At that time use with the center pin and the core bit shank provided as optional accessories.

1. Mounting

WARNING

To prevent accidents, make sure to turn the switch off and disconnect the battery.

- (1) Mount the core bit to the core bit shank. (Fig. 28)
- Lubricate the thread of the core bit shank to facilitate disassembly.
- (2) Mount the core bit shank to the Rotary Hammer. (Fig. 29)
- (3) Insert the center pin into the guide plate until it stops.
- (4) Engage the guide plate with the core bit, and turn the guide plate to left or right so that it does not fall even if it faces downward. (Fig. 30)

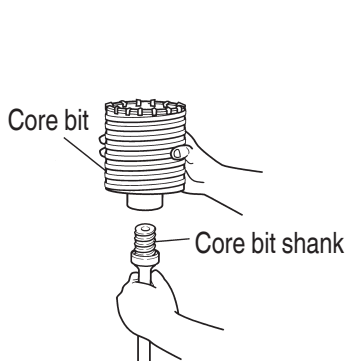

Fig. 28

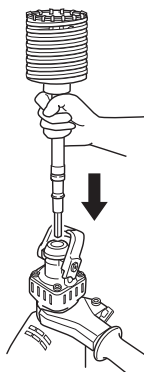

Fig. 29

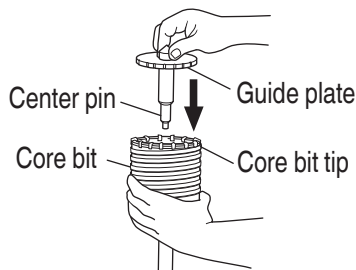

Fig. 30

English

2. How to bore (Fig. 31)

- (1) Install the battery.
- (2) A spring is installed in the center pin. Push it lightly to the wall or the floor straight. Connect all over the surface of the core bit tip and start operating.
- (3) When boring about 5 mm in depth the position of the hole will establish. Bore after that removing the center pin and the guide plate from core bit.
- (4) Application of excessive force will not only expedite the work, but will deteriorate the tip edge of the drill bit, resulting in reduced service life of the rotary hammer.

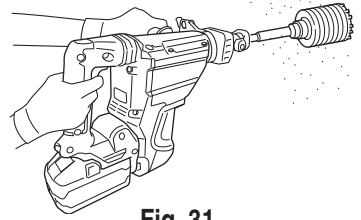

Fig. 31

WARNING

When removing the center pin and the guide plate, turn OFF the switch and disconnect the battery.

3. Dismounting (Fig. 32)

Remove the core bit shank from the rotary hammer and strike the head of the core bit shank strongly two or three times with a manual hammer holding the core bit, then the thread becomes loose and the core bit can be removed.



Fig. 32

REACTIVE FORCE CONTROL

This product is equipped with a Reactive Force Control (RFC) feature that reduces jerking of the tool body.

If the tool bit is suddenly overburdened, any jerking of the tool body is reduced by activation of the slip clutch or by stopping of the motor by the sensor built into the tool body. If the motor is stopped because of overburdening detection by the controller, the display lamp will blink while the switch is pulled. In addition, the lamp will continue blinking for approximately three seconds after the switch is released. The motor will remain stopped while the lamp is blinking. (Fig. 33)

Because the RFC feature may not activate or its performance may be insufficient depending on the working environment and conditions, be careful not to suddenly overburden the tool bit and hold power tool firmly while operating.

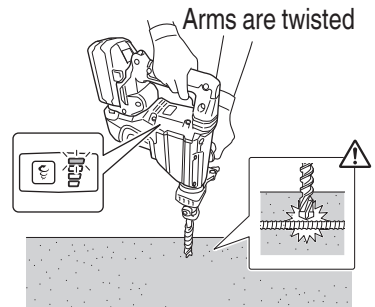

Fig. 33

- Possible causes of sudden overburdening
 - ① Tool bit biting into material
 - ② Impact against nails, metal or other hard objects
 - ③ Tasks involving prying or any excess application of pressure, etc.

Also, other causes include any combination of the aforementioned.

- When the reactive force control (RFC) is triggered
When the RFC is triggered and the motor stops, turn off the tool's switch and remove the cause of the overburdening before continuing operation.

OPERATIONAL CAUTIONS

Resting the unit after continuous work

- (1) The power tool is equipped with a temperature protection circuit to protect the motor. Continuous work may cause the temperature of the unit to rise, activating the temperature protection circuit and automatically stopping operation. If this happens, allow the power tool to cool before resuming use.
- (2) After use for continuous works, rest the unit for 15 minutes or so when replacing the battery. The temperature of the motor, switch, etc., will rise if the work is started again immediately after battery replacement, eventually resulting in burnout.

MAINTENANCE AND INSPECTION

WARNING

Be sure to turned off the switch and remove the battery before maintenance and inspection.

1. Inspecting the tool bits
Since use of a dull tool will cause motor malfunctioning and degraded efficiency, replace the tool bit with a new one or sharpening without delay when abrasion is noted.
2. Inspecting the screws
Regularly inspect all mounting screws and ensure that they are properly tightened. Should any of the screws be loose, retighten them immediately.

WARNING

Using this Rotary Hammer with loosen screws is extremely dangerous.

3. Maintenance of the motor
The motor unit winding is the very "heart" of the power tool. Exercise due care to ensure the winding does not become damaged and/or wet with oil or water.

English

4. Grease replacement
This Rotary Hammer is of full air-tight construction to protect against dust. Therefore, this Rotary Hammer can be used without lubrication for long periods. Refer to the following for grease replacement.
 - Grease Replacement Period
After purchase, replace grease after every 6 months of usage. Ask for grease replacement at the nearest authorized Service Center.
5. Inspection of terminals (tool and battery)
Check to make sure that swarf and dust have not collected on the terminals. On occasion check prior, during and after operation.

CAUTION

**Remove any swarf or dust which may have collected on the terminals.
Failure to do so may result in malfunction.**

6. Cleaning on the outside
When the power tool is stained, wipe with a soft dry cloth or a cloth moistened with soapy water. Do not use chloric solvents, gasoline or paint thinner, for they melt plastics.
7. Cleaning the battery installation compartment and the battery
After drilling concrete, if concrete dust has accumulated on the battery installation compartment and the battery, clean off the accumulated concrete dust with an air blow gun or a dry cloth before using the tool.
(Fig. 34)
Also, after cleaning, ensure that the battery can be installed and removed smoothly from the tool.

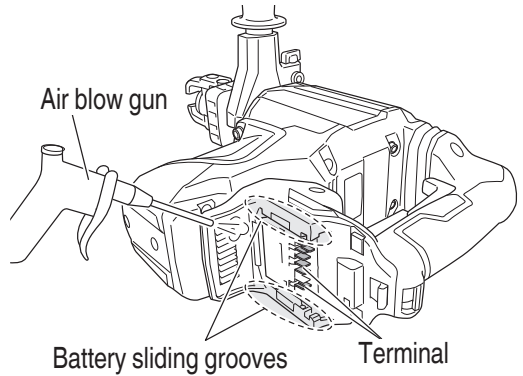

CAUTION

Using the tool when the battery is covered with concrete dust may lead to accidents such as the battery falling during use. Furthermore, such use may cause a malfunction or contact failure between the battery and the terminals.

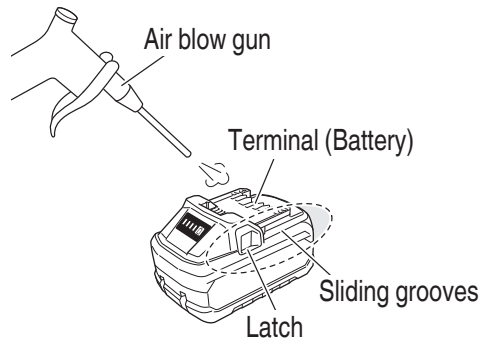

Fig. 34

8. Disposal of the exhausted battery

WARNING

Do not dispose of the exhausted battery. The battery must explode if it is incinerated. The product that you have purchased contains a rechargeable battery. The battery is recyclable. At the end of its useful life, under various state and local laws, it may be illegal to dispose of this battery into the municipal waste stream. Check with your local solid waste officials for details in your area for recycling options or proper disposal.

9. Storage

Store the power tool in a place in which the temperature is less than 40°C and out of reach of children.

NOTE

Storing lithium-ion batteries

Make sure the lithium-ion batteries have been fully charged before storing them.

Prolonged storage (3 months or more) of batteries with a low charge may result in performance deterioration, significantly reducing battery usage time or rendering the batteries incapable of holding a charge.

However, significantly reduced battery usage time may be recovered by repeatedly charging and using the batteries two to five times.

If the battery usage time is extremely short despite repeated charging and use, consider the batteries dead and purchase new batteries.

10. Service and repairs

All quality power tools will eventually require servicing or replacement of parts because of wear from normal use. To assure that only authorized replacement parts will be used, all service and repairs must be performed by HIKOKI AUTHORIZED SERVICE CENTER, ONLY.

CAUTION

In the operation and maintenance of power tools, the safety regulations and standards prescribed in each country must be observed.

Important notice on the batteries for the HIKOKI cordless power tools

Please always use one of our designated genuine batteries. We cannot guarantee the safety and performance of our cordless power tool when used with batteries other than these designated by us, or when the battery is disassembled and modified (such as disassembly and replacement of cells or other internal parts).

TROUBLESHOOTING

Use the inspections in the table below if the tool does not operate normally. If this does not remedy the problem, consult your dealer or the HiKOKI Authorized Service Center.

1. Power tool

Symptom	Possible cause	Remedy
Tool doesn't run	No remaining battery power	Charge the battery.
	Battery isn't securely attached.	Push in the battery until a click is heard.
	Concrete dust has accumulated on the terminals of the battery installation compartment as well as on the battery sliding grooves.	Clean off the accumulated concrete dust with a dry cloth.
	The battery was attached while the switch trigger was ON.	Attach the battery when the switch trigger is OFF.
Tool suddenly stopped	Tool was overburdened	Remove the cause of the overburdening. See "Reactive force control".
	Reactive force control was activated	
	Battery or tool overheated	Allow the tool and battery to thoroughly cool.
Tool bits -can't be attached -fall off	The shape of the attachment portion doesn't match	For the hexagon shank type, use a bit with a diameter that is within the designated range.
Holes can't be smoothly drilled.	The drill is worn	Replace with a new drill.
Battery cannot be installed	Attempting to install a battery other than that specified for the tool.	Please install a multi volt type battery.

2. Charger

Symptom	Possible cause	Remedy
The charge indicator lamp rapidly flickers purple, and battery charging doesn't begin.	The battery is not inserted all the way.	Insert the battery firmly.
	There is foreign matter in the battery terminal or where the battery is attached.	Remove the foreign matter.
The charge indicator lamp blinks red, and battery charging doesn't begin.	The battery is not inserted all the way.	Insert the battery firmly.
	The battery is overheated.	If left alone, the battery will automatically begin charging if its temperature decreases, but this may reduce battery life. It is recommended that the battery be cooled in a well-ventilated location away from direct sunlight before charging it.
Battery usage time is short even though the battery is fully charged.	The battery's life is depleted.	Replace the battery with a new one.
The battery takes a long time to charge.	The temperature of the battery, the charger, or the surrounding environment is extremely low.	Charge the battery indoors or in another warmer environment.
	The charger's vents are blocked, causing its internal components to overheat.	Avoid blocking the vents.
	The cooling fan is not running.	Contact a HiKOKI Authorized Service Center for repairs.
The USB power lamp has switched off and the USB device has stopped charging.	The battery's capacity has become low.	Replace the battery with one that has capacity remaining.
		Plug the charger's power plug into an electric socket.
USB power lamp does not switch off even though the USB device has finished charging.	The USB power lamp lights up green to indicate that USB charging is possible.	This is not a malfunction.

English

Symptom	Possible cause	Remedy
It is unclear what the charging status of a USB device is, or whether its charging is complete.	The USB power lamp does not switch off even when charging is complete.	Examine the USB device that is charging to confirm its charging status.
Charging of a USB device pauses midway.	The charger was plugged into an electrical socket while the USB device was being charged using the battery as the power source.	This is not a malfunction. The charger pauses USB charging for about 5 seconds when it is differentiating between power sources.
	A battery was inserted into the charger while the USB device was being charged using a power socket as the power source.	
Charging of the USB device pauses midway when the battery and the USB device are being charged at the same time.	The battery has become fully charged.	This is not a malfunction. The charger pauses USB charging for about 5 seconds while it checks whether the battery has successfully completed charging.
Charging of the USB device doesn't start when the battery and the USB device are being charged at the same time.	The remaining battery capacity is extremely low.	This is not a malfunction. When the battery capacity reaches a certain level, USB charging automatically begins.

SELECTING ACCESSORIES

Select accessories that are suited to a specific task.
For details contact HiKOKI Authorized Service Center.

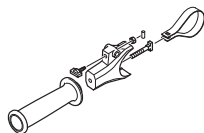

Side Handle (Part Number: 380210)
Mount Ass'y (Part Number: 380209)
Handle Bolt (Part Number: 331247)
Band (Part Number: 380208)

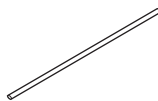

Part Number: 971786
Stopper

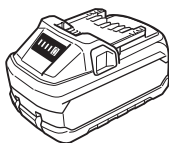

BSL36..18..
Battery

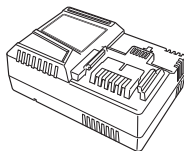

UC18YSL3
(14.4 V-18 V)
Charger

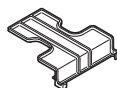

Part Number:
329897
Battery cover

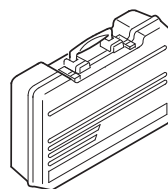

Part Number:
380211
Plastic Case

English

- Through-hole drilling (Rotation + Hammering)



(1) Drill bit (hexagon shank)

External dia.	Overall length			
	280 mm	400 mm	505 mm	550 mm
	Code No.	Code No.	Code No.	Code No.
16 mm	985721	985720	985722	991330
18 mm	-	-	-	991331
19 mm	985724	985723	985725	991332
20 mm	-	-	-	991333
22 mm	985727	985726	985728	991335
25 mm	985730	985729	985731	991336
28 mm	985733	985732	985734	991337
30 mm	-	-	-	991338
32 mm	985736	985735	985737	991339
35 mm	-	-	-	991340
38 mm	985739	985738	985740	991341
40 mm	313322	-	-	-

- Large dia. hole boring (Rotation + Hammering)



+

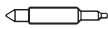

+



+

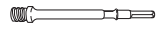

(Guide plate)

(1) Center pin

(2) Core bit

(3) Core bit shank
(hexagon shank)

External dia. of core bit	Code No.
50 mm	950475
105 mm	955169

Code No.
955165

External dia.	Code No.
50 mm	985380
105 mm	955159

Code No.
955163

- Anchor work (for Automatic boring anchors)



- (1) Anchor adapter (for Rotation + Hammering)

Anchor size	Code No.
W1/4 (No. 20)	985756
W5/16 (No. 25)	985757
W3/8 (No. 30)	985758
W1/2 (No. 40)	985759
W5/8 (No. 50)	985760



- (3) Drift key

Code No. 944574

- (2) Anchor adapter (for Hammering)

Anchor size	Code No.
W3/8 (No. 30)	981929
W1/2 (No. 40)	981930
W5/8 (No. 50)	981931

- Crushing (Hammering)

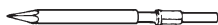

- (1) Bull point

Overall length	Shank type	Code No.
280 mm	Round	981922
	Hexagon	980752
450 mm	Round	981923
	Hexagon	980753

- Groove digging and edging (Hammering)

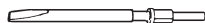

- (1) Cold chisel

Overall length	Code No.
280 mm	981925
450 mm	981926

- Asphalt cutting (Hammering)

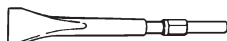

- (1) Cutter

Overall length	Width	Code No.
280 mm	45 mm	981924

English

- Digging

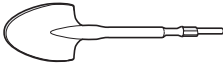

- (1) Scoop

Code No. 956126

- Surface Roughing (Hammering)



+

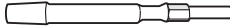

- (1) Bushing Tool

Code No. 955183

- (2) Shank

Overall length	Code No.
250 mm	955186

- Tamping (Hammering)



+



- (1) Rammer

Code No. 955181

- (2) Shank

Overall length	Code No.
250 mm	955186

- Syringe (for chip removal)

Code No. 318085



- Battery (BSL36..18..)

NOTE

Specifications are subject to change without any obligation on the part of the HIKOKI.

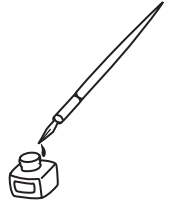

服务中心
高壹工机商业(上海)有限公司
上海市闵行区浦江工业园区三鲁路3585号7幢3楼

制造商
高壹工机(马来西亚)有限公司
马来西亚柔佛州士乃第二工业区

Koki Holdings Co., Ltd.

306

编号: C99274121 M

发行日期: 2023年6月

中国印刷