

HIKOKI

DH 26PMX

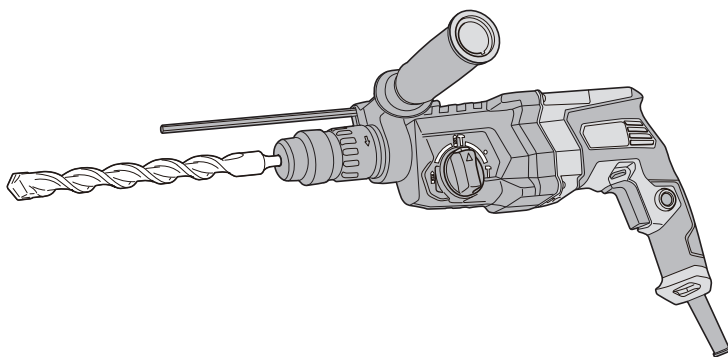

Handling instructions



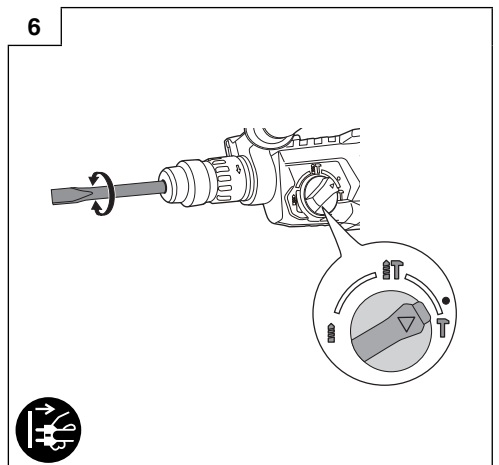
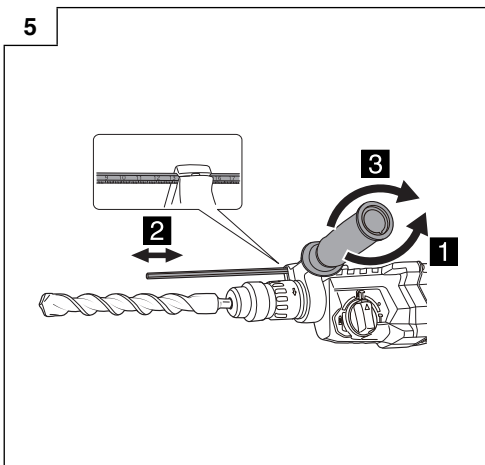
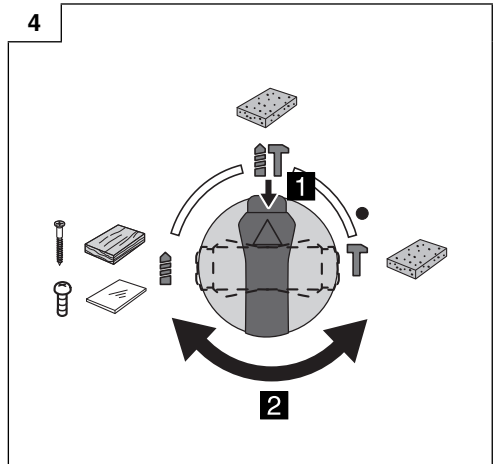
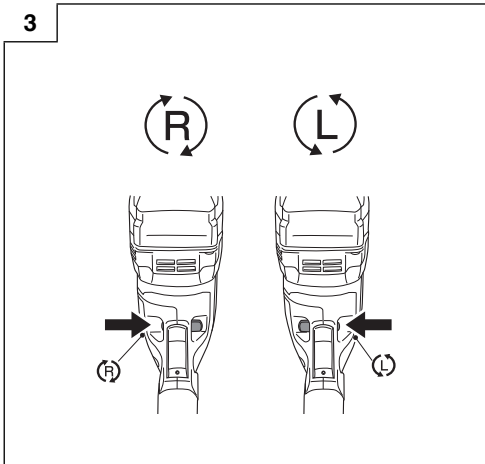
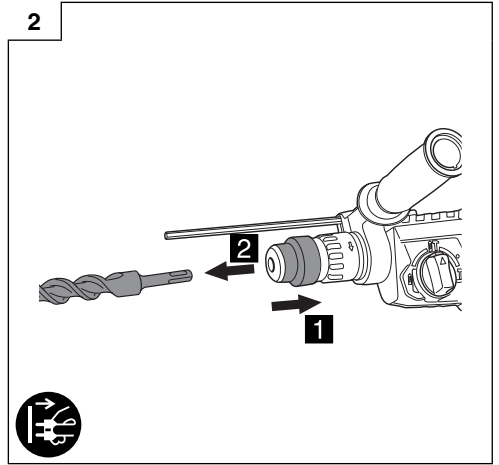
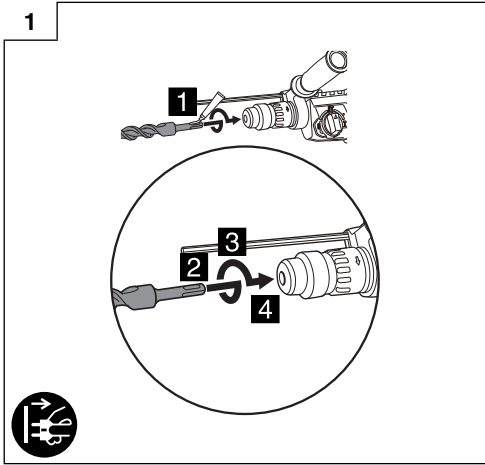

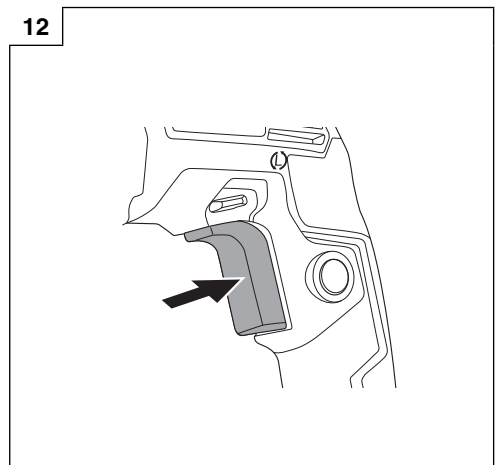
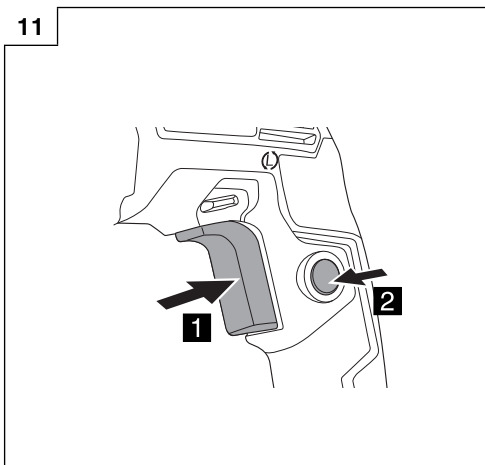
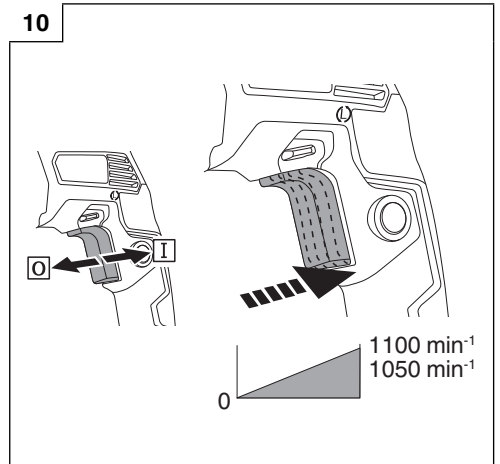
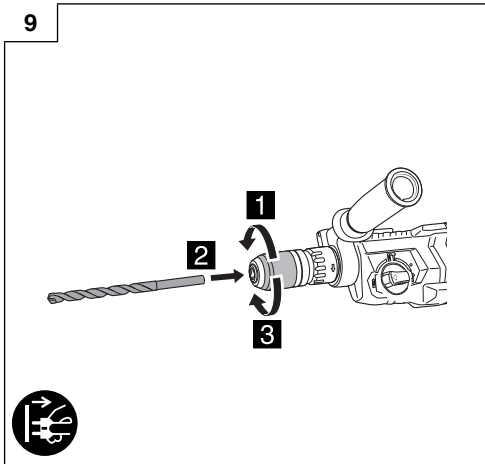
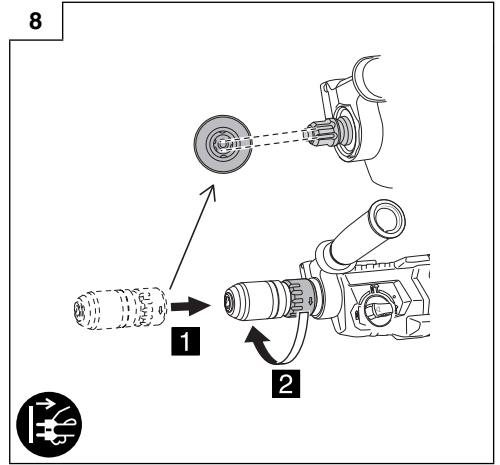
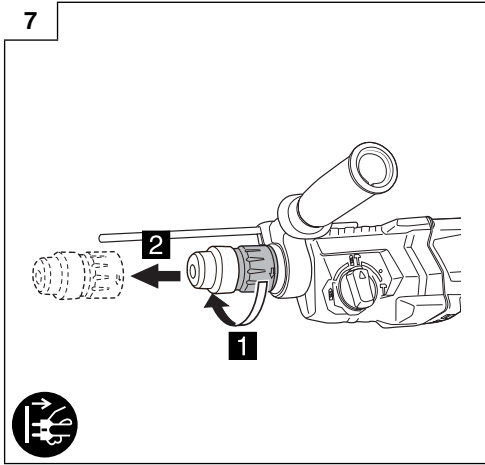

13

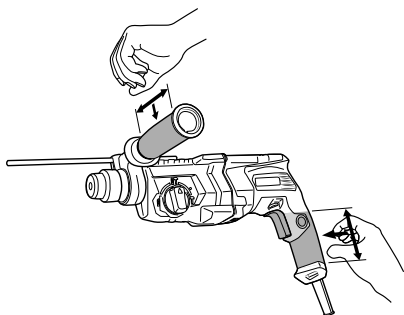

14

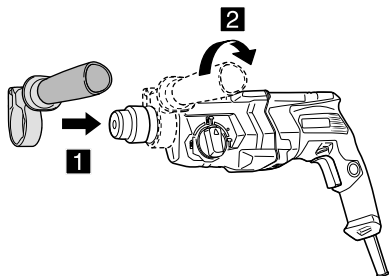

GENERAL POWER TOOL SAFETY WARNINGS

WARNING

Read all safety warnings, instructions, illustrations and specifications provided with this power tool.

Failure to follow all instructions listed below may result in electric shock, fire and/or serious injury.

Save all warnings and instructions for future reference.

The term "power tool" in the warnings refers to your mains-operated (corded) power tool or battery-operated (cordless) power tool.

1) Work area safety

- a) **Keep work area clean and well lit.**
Cluttered or dark areas invite accidents.
- b) **Do not operate power tools in explosive atmospheres, such as in the presence of flammable liquids, gases or dust.**
Power tools create sparks which may ignite the dust or fumes.
- c) **Keep children and bystanders away while operating a power tool.**
Distractions can cause you to lose control.

2) Electrical safety

- a) **Power tool plugs must match the outlet. Never modify the plug in any way. Do not use any adapter plugs with earthed (grounded) power tools.**
Unmodified plugs and matching outlets will reduce risk of electric shock.
- b) **Avoid body contact with earthed or grounded surfaces, such as pipes, radiators, ranges and refrigerators.**
There is an increased risk of electric shock if your body is earthed or grounded.
- c) **Do not expose power tools to rain or wet conditions.**
Water entering a power tool will increase the risk of electric shock.
- d) **Do not abuse the cord. Never use the cord for carrying, pulling or unplugging the power tool. Keep cord away from heat, oil, sharp edges or moving parts.**
Damaged or entangled cords increase the risk of electric shock.
- e) **When operating a power tool outdoors, use an extension cord suitable for outdoor use.**
Use of a cord suitable for outdoor use reduces the risk of electric shock.
- f) **If operating a power tool in a damp location is unavoidable, use a residual current device (RCD) protected supply.**
Use of an RCD reduces the risk of electric shock.

3) Personal safety

- a) **Stay alert, watch what you are doing and use common sense when operating a power tool. Do not use a power tool while you are tired or under the influence of drugs, alcohol or medication.**
A moment of inattention while operating power tools may result in serious personal injury.
- b) **Use personal protective equipment. Always wear eye protection.**
Protective equipment such as a dust mask, non-skid safety shoes, hard hat or hearing protection used for appropriate conditions will reduce personal injuries.

- c) **Prevent unintentional starting. Ensure the switch is in the off-position before connecting to power source and/or battery pack, picking up or carrying the tool.**

Carrying power tools with your finger on the switch or energising power tools that have the switch on invites accidents.

- d) **Remove any adjusting key or wrench before turning the power tool on.**
A wrench or a key left attached to a rotating part of the power tool may result in personal injury.
 - e) **Do not overreach. Keep proper footing and balance at all times.**
This enables better control of the power tool in unexpected situations.
 - f) **Dress properly. Do not wear loose clothing or jewellery. Keep your hair and clothing away from moving parts.**
Loose clothes, jewellery or long hair can be caught in moving parts.
 - g) **If devices are provided for the connection of dust extraction and collection facilities, ensure these are connected and properly used.**
Use of dust collection can reduce dust-related hazards.
 - h) **Do not let familiarity gained from frequent use of tools allow you to become complacent and ignore tool safety principles.**
A careless action can cause severe injury within a fraction of a second.
- #### 4) Power tool use and care
- a) **Do not force the power tool. Use the correct power tool for your application.**
The correct power tool will do the job better and safer at the rate for which it was designed.
 - b) **Do not use the power tool if the switch does not turn it on and off.**
Any power tool that cannot be controlled with the switch is dangerous and must be repaired.
 - c) **Disconnect the plug from the power source and/or remove the battery pack, if detachable, from the power tool before making any adjustments, changing accessories, or storing power tools.**
Such preventive safety measures reduce the risk of starting the power tool accidentally.
 - d) **Store idle power tools out of the reach of children and do not allow persons unfamiliar with the power tool or these instructions to operate the power tool.**
Power tools are dangerous in the hands of untrained users.
 - e) **Maintain power tools and accessories. Check for misalignment or binding of moving parts, breakage of parts and any other condition that may affect the power tool's operation. If damaged, have the power tool repaired before use.**
Many accidents are caused by poorly maintained power tools.
 - f) **Keep cutting tools sharp and clean.**
Properly maintained cutting tools with sharp cutting edges are less likely to bind and are easier to control.
 - g) **Use the power tool, accessories and tool bits etc. in accordance with these instructions, taking into account the working conditions and the work to be performed.**
Use of the power tool for operations different from those intended could result in a hazardous situation.

- h) **Keep handles and grasping surfaces dry, clean and free from oil and grease.**

Slippery handles and grasping surfaces do not allow for safe handling and control of the tool in unexpected situations.

5) **Service**

- a) **Have your power tool serviced by a qualified repair person using only identical replacement parts.**

This will ensure that the safety of the power tool is maintained.

PRECAUTION

Keep children and infirm persons away.

When not in use, tools should be stored out of reach of children and infirm persons.

ROTARY HAMMER SAFETY WARNINGS

Safety instructions for all operations

1. **Wear ear protectors**
Exposure to noise can cause hearing loss.
2. **Use auxiliary handle(s), if supplied with the tool.**
Loss of control can cause personal injury.
3. **Hold the power tool by insulated gripping surfaces, when performing an operation where the cutting accessory may contact hidden wiring or its own cord.**
Cutting accessory contacting a "live" wire may make exposed metal parts of the power tool "live" and could give the operator an electric shock.

Safety instructions when using long drill bits with rotary hammers

4. **Always start drilling at low speed and with the bit tip in contact with the workpiece.**
At higher speeds, the bit is likely to bend if allowed to rotate freely without contacting the workpiece, resulting in personal injury.
5. **Apply pressure only in direct line with the bit and do not apply excessive pressure.**
Bits can bend causing breakage or loss of control, resulting in personal injury.















ADDITIONAL SAFETY WARNINGS

1. Ensure that the power source to be utilized conforms to the power requirements specified on the product nameplate.
2. Ensure that the power switch is in the OFF position.
If the plug is connected to a receptacle while the power switch is in the ON position, the power tool will start operating immediately, which could cause a serious accident.
3. When the work area is removed from the power source, use an extension cord of sufficient thickness and rated capacity. The extension cord should be kept as short as practicable.
4. Do not touch the bit during or immediately after operation. The bit becomes very hot during operation and could cause serious burns.
5. Before starting to break, chip or drill into a wall, floor or ceiling, thoroughly confirm that such items as electric cables or conduits are not buried inside.
6. Always hold the body handle and side handle of the power tool firmly. Otherwise the counterforce produced may result in inaccurate and even dangerous operation.
7. **Wear a dust mask**
Do not inhale the harmful dusts generated in drilling or chiseling operation. The dust can endanger the health of yourself and bystanders.
8. **Mounting the tool**
 - To prevent accidents, make sure to turn the switch off and disconnect the plug from the receptacle.
 - When using tools such as bull points, drill bits, etc., make sure to use the genuine parts designated by our company.
 - Clean the shank portion of the tool.
 - Check the latching by pulling on the tool.
9. To prevent accidents, make sure to turn the switch off and disconnect the plug from the receptacle when the drill bits and other various parts are installed or removed. The power switch should also be turned off during a work break and after work.
10. **Rotation + hammering**
Using drill bit holder (standard accessories)
When the drill bit touches construction iron bar, the bit will stop immediately and the rotary hammer will react to revolve. Therefore firmly tighten the side handle.
11. **Rotation only**
To drill wood or metal material using drill chuck holder (standard accessories)
 - Application of force more than necessary will not only expedite the work, but will deteriorate the tip edge of the drill bit and reduce the service life of the rotary hammer in addition.
 - Drill bits may snap off while withdrawing the rotary hammer from the drilled hole. For withdrawing, it is important to use a pushing motion.
 - Do not attempt to drill anchor holes or holes in concrete with the machine set in the rotation only function.
 - Do not attempt to use the rotary hammer in the rotation and hammering function with the drill chuck holder attached. This would seriously shorten the service life of every component of the machine.
12. **Hammering only**
Using drill bit holder (standard accessories)
13. Make sure to securely hold the tool as shown in **Fig. 13** during operation.

SYMBOLS

WARNING

The following show symbols used for the machine. Be sure that you understand their meaning before use.

	DH26PMX: Rotary Hammer
	To reduce the risk of injury, user must read instruction manual.
	Only for EU countries Do not dispose of electric tools together with household waste material! In observance of European Directive 2012/19/EU on waste electrical and electronic equipment and its implementation in accordance with national law, electric tools that have reached the end of their life must be collected separately and returned to an environmentally compatible recycling facility.
V	Rated voltage (Ensure that the power source to be utilized conforms to the power requirements specified on the product nameplate.)
P	Power Input
n_0	No-load speed
Bpm	Full-load impact rate
ϕ_{max}	Drilling diameter, max.
	Weight (According to EPTA-Procedure 01/2014)
	Concrete
	Steel
	Wood
	Rotation and hammering function
	Rotation only function
	Hammering only function
	Switching ON
	Switching OFF
	Disconnect mains plug from electrical outlet
	Class II tool

STANDARD ACCESSORIES

In addition to the main unit (1 unit), the package contains the accessories listed in the below.

- Plastic case 1
- Side handle 1
- Depth gauge 1
- Drill chuck holder 1

Standard accessories are subject to change without notice.

APPLICATIONS

Rotation and hammering function 

- Drilling anchor holes
- Drilling holes in concrete
- Drilling holes in tile

Rotation only function 

- Drilling in steel or wood
- Tightening machine screws, wood screws

Hammering only function 

- Light-duty chiselling of concrete, groove digging and edging.

SPECIFICATIONS

The specifications of this machine are listed in the Table on page 9.

NOTE

Due to HiKOKI's continuing program of research and development, the specifications herein are subject to change without prior notice.

MOUNTING AND OPERATION

Action	Figure	Page
Inserting SDS-plus tools	1	2
Removing SDS-plus tools	2	2
Selecting rotation direction	3	2
Selecting the operating mode	4	2
Adjusting the drilling depth	5	2
Changing the chisel position	6	2
Removing the quick release chuck*1	7	3
Inserting the quick release chuck	8	3
Inserting round shank applications tools	9	3
Switching on and off and setting the speed	10	3
Locking-on the On / Off switch	11	3
Releasing the On / Off switch	12	4
Installing the side handle	14	4
Selecting accessories*2	-	10

*1 If it is hard to pull out the drill chuck holder or the drill bit holder, align the change lever with the  mark and turn the lock grip.

*2 For detailed information regarding each tool, contact a HiKOKI authorized service center.

LUBRICATION

This Rotary Hammer is of full air-tight construction to protect against dust.

Therefore, this Rotary Hammer can be used without lubrication for long periods. Replace the grease whenever you change the carbon brush to maintain the service life.

Further use of the rotary hammer with lock off grease will cause the machine to seize up reduce the service life.

CAUTION

A special grease is used with this machine, therefore, the normal performance of the machine may be badly affected by use of other grease. Please be sure to let one of our service agents undertake replacement of the grease.

MAINTENANCE AND INSPECTION

1. Inspecting the tools

Since use of a dull tool will cause motor malfunctioning and degraded efficiency, replace the tool with new ones or resharpen them without delay when abrasion is noted.

2. Inspecting the mounting screws

Regularly inspect all mounting screws and ensure that they are properly tightened. Should any of the screws be loose, retighten them immediately. Failure to do so could result in serious hazard.

3. Maintenance of the motor

The motor unit winding is the very "heart" of the power tool.

Exercise due care to ensure the winding does not become damaged and/or wet with oil or water.

4. Inspecting the carbon brushes

For your continued safety and electrical shock protection, carbon brush inspection and replacement on this machine should ONLY be performed by a HiKOKI Authorized Service Center.

5. Replacing supply cord

If the replacement of the supply cord is necessary, this has to be done by the manufacturer of this agent in order to avoid a safety hazard.

CAUTION

In the operation and maintenance of power tools, the safety regulations and standards prescribed in each country must be observed.

GUARANTEE

We guarantee HiKOKI Power Tools in accordance with statutory/country specific regulation. This guarantee does not cover defects or damage due to misuse, abuse, or normal wear and tear. In case of complaint, please send the Power Tool, undismantled, with the GUARANTEE CERTIFICATE found at the end of this Handling instruction, to a HiKOKI Authorized Service Center.

IMPORTANT

Correct connection of the plug

The wires of the main lead are coloured in accordance with the following code:

Blue: — Neutral

Brown: — Live

As the colours of the wires in the main lead of this tool may not correspond with the coloured markings identifying the terminals in your plug proceed as follows:

The wire coloured blue must be connected to the terminal marked with the letter N or coloured black. The wire coloured brown must be connected to the terminal marked with the letter L or coloured red. Neither core must be connected to the earth terminal.

NOTE:

This requirement is provided according to BRITISH STANDARD 2769: 1984.

Therefore, the letter code and colour code may not be applicable to other markets except The United Kingdom.

Information concerning airborne noise and vibration

The measured values were determined according to EN62841 and declared in accordance with ISO 4871.

Measured A-weighted sound power level: 102 dB (A)

Measured A-weighted sound pressure level: 94 dB (A)

Uncertainty K: 3 dB (A).

Wear hearing protection.

Vibration total values (triax vector sum) determined according to EN62841.

Hammer drilling into concrete:

Vibration emission value $a_{h, HD} = 14.7 \text{ m/s}^2$

Uncertainty K = 1.5 m/s²

Equivalent chiselling value:

Vibration emission value $a_{h, CHeq} = 14.0 \text{ m/s}^2$

Uncertainty K = 1.5 m/s²

The declared vibration total value has been measured in accordance with a standard test method and may be used for comparing one tool with another.

It may also be used in a preliminary assessment of exposure.





WARNING

○ The vibration emission during actual use of the power tool can differ from the declared total value depending in the ways in which the tool is used.

○ Identify safety measures to protect the operator that are based on an estimation of exposure in the actual conditions of use (taking account of all parts of the operating cycle such as the times when the tool is switched off and when it is running idle in addition to the trigger time).

NOTE

Due to HiKOKI's continuing program of research and development, the specifications herein are subject to change without prior notice.

	DH26PMX 
V	(110 V, 230 V) ~
P	830 W
n_0	0–1100 min ⁻¹
Bpm	0–4300 min ⁻¹
ϕ max 	3.4–26 mm
ϕ max 	13 mm
ϕ max 	32 mm
	3.0 kg

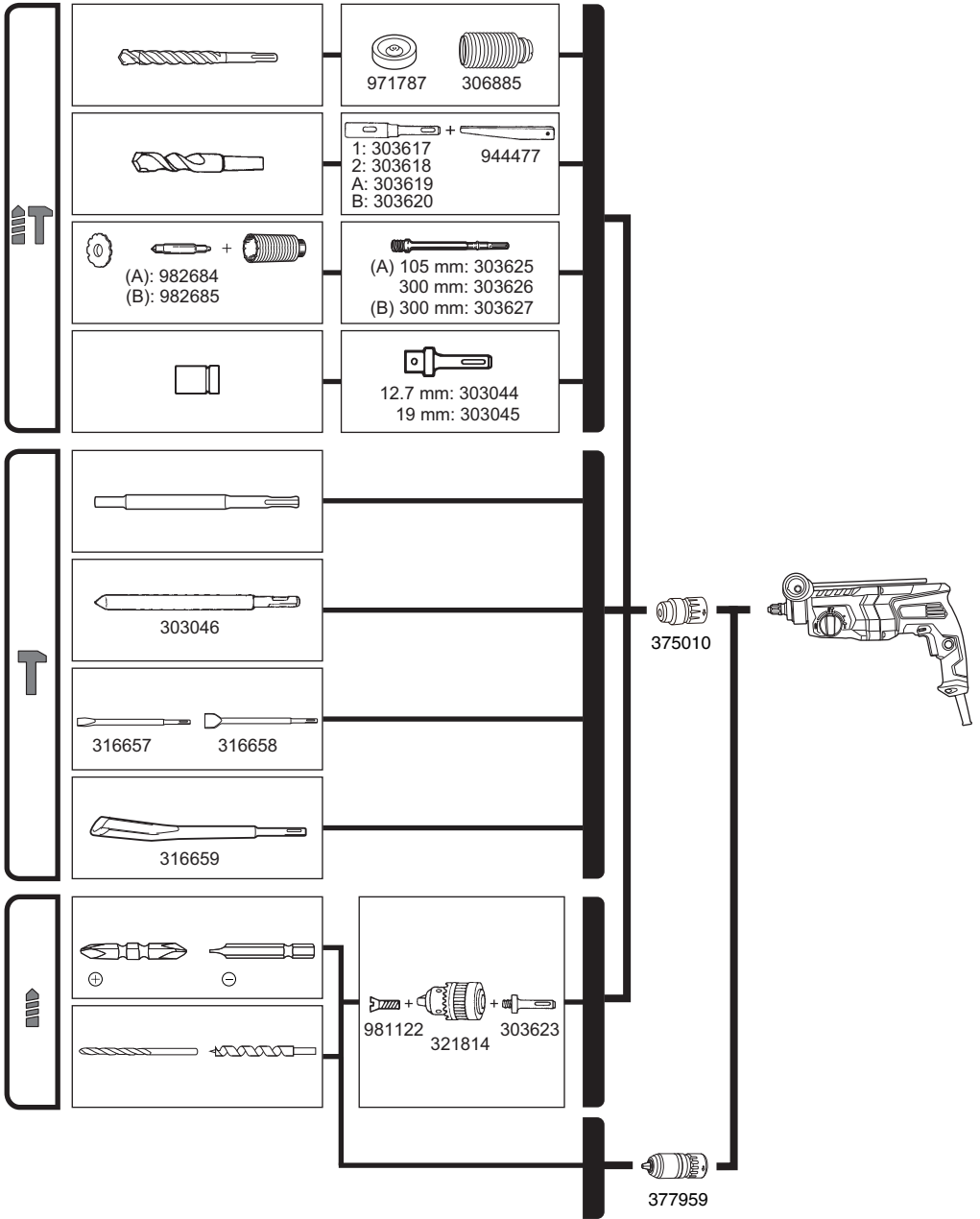



GUARANTEE CERTIFICATE

Model No.

Serial No.

Date of Purchase

Customer Name and Address

Dealer Name and Address
(Please stamp dealer name and address)

Hikoki Power Tools (U.K.) Ltd.

25 Majestic Road, Southampton, SO16 OYT, United Kingdom

Tel: +44 1908 660663

Fax: +44 1908 606642

URL: <http://www.hikoki-powertools.uk>



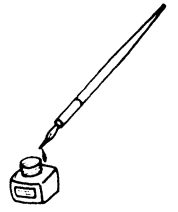

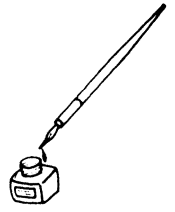

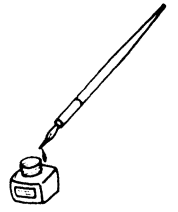

EC DECLARATION OF CONFORMITY

We declare under our sole responsibility that Rotary Hammer, identified by type and specific identification code *1), is in conformity with all relevant requirements of the directives *2) and standards *3). Technical file at *4) – See below. The European Standard Manager at the representative office in Europe is authorized to compile the technical file. The declaration is applicable to the product affixed CE marking.

*1) DH26PMX C361395R C361396M

*2) 2006/42/EC, 2014/30/EU, 2011/65/EU

*3) EN62841-1:2015+A1:2022
EN IEC 62841-2-6:2020+A11:2020
EN55014-1:2006+A1:2009+A2:2011
EN55014-2:1997+A1:2001+A2:2008
EN61000-3-2:2014
EN61000-3-3:2013

*4) Representative office in Europe

Hikoki Power Tools Deutschland GmbH
Siemensring 34, 47877 Willich, Germany

28. 2. 2023
Akihisa Yahagi
European Standard Manager

Head office in Japan
Koki Holdings Co., Ltd.
Shinagawa Intercity Tower A, 15-1, Konan 2-chome,
Minato-ku, Tokyo, Japan



28. 2. 2023

K. Yokoyama
General Manager of
Quality Assurance Division

DECLARATION OF CONFORMITY

We declare under our sole responsibility that Rotary Hammer, identified by type and specific identification code *1), is in conformity with all relevant requirements of the UK regulations *2) and Designated standards *3). Technical file at *4) – See below.

This declaration is applicable to the product affixed UKCA marking.

*1) DH26PMX C361395R C361396M

*2) S.I. 2008/1597, S.I. 2016/1091, S.I. 2012/3032

*3) EN62841-1:2015+A1:2022

EN IEC 62841-2-6:2020+A11:2020

EN55014-1:2006+A1:2009+A2:2011

EN55014-2:1997+A1:2001+A2:2008

EN61000-3-2:2014

EN61000-3-3:2013

*4) Importer and authorized person to compile the technical file

Hikoki Power Tools (U.K.) Ltd.

25 Majestic Road, Southampton, SO16 OYT,
United Kingdom

Head office in Japan

Koki Holdings Co., Ltd.

Shinagawa Intercity Tower A, 15-1, Konan 2-chome,
Minato-ku, Tokyo, Japan

**UK
CA**

28. 2. 2023

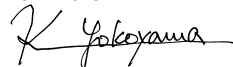

K. Yokoyama
General Manager of
Quality Assurance Division

Koki Holdings Co., Ltd.