

HIKOKI

电刨
Planer

P 20ST

中文
English

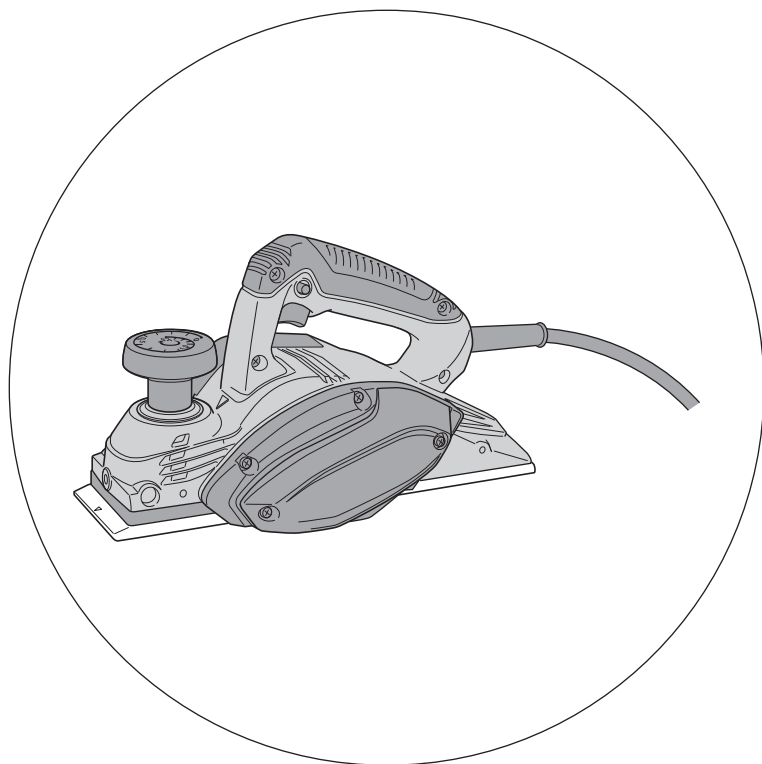

保留备用
Keep for future reference



使用说明书
Handling instructions



目次

电动工具通用安全警告.....	2	刨平方法.....	6
电刨安全警告.....	4	炭化刃之装卸和刀刃高度之调整	
其他安全警告.....	4	(适用于双刃型).....	7
符号.....	5	刀刃的装卸及刀刃高度之调整	
规格.....	5	(适用于反复磨锋型刀刃).....	9
标准附件.....	5	研磨可反复磨锋的刀刃.....	10
选购附件(分开销售).....	5	装卸尘适配器.....	10
用途.....	6	维护和检查.....	11
作业之前.....	6	附加信息.....	13

电动工具通用安全警告

⚠ 警告！

阅读随电动工具提供的所有安全警告、说明、图示和规定。
不遵照以下所列说明会导致电击、着火和 / 或严重伤害。

保存所有警告和说明书以备查阅。

在所有下列的警告中术语“电动工具”指市电驱动(有线)电动工具或电池驱动(无线)电动工具。

a) 工作场地的安全

- 1) 保持工作场地清洁和明亮。
杂乱和黑暗的场地会引发事故。
- 2) 不要在易爆环境，如有易燃液体、气体或粉尘的环境下操作电动工具。
电动工具产生的火花会点燃粉尘或气体。
- 3) 操作电动工具时，远离儿童和旁观者。
注意力不集中会使你失去对工具的控制。

b) 电气安全

- 1) 电动工具插头必须与插座相配。绝不能以任何方式改装插头。需接地的电动工具不能使用任何转换插头。
未经改装的插头和相配的插座将降低电击风险。
- 2) 避免人体接触接地表面，如管道、散热片和冰箱。
如果你身体接触接地表面会增加电击风险。
- 3) 不得将电动工具暴露在雨中或潮湿环境中。
水进入电动工具将增加电击风险。

- 4) 不得滥用软线。绝不能用软线搬运、拉动电动工具或拔出其插头。使软线远离热源、油、锐边或运动部件。
受损或缠绕的软线会增加电击风险。
- 5) 当在户外使用电动工具时，使用适合户外使用的延长线。
适合户外使用的电线将降低电击风险。
- 6) 如果无法避免在潮湿环境中操作电动工具，应使用带有剩余电流装置（RCD）保护的电源。
RCD的使用可降低电击风险。

c) 人身安全

- 1) 保持警觉，当操作电动工具时关注所从事的操作并保持清醒。当你感到疲倦，或在有药物、酒精或治疗反应时，不要操作电动工具。
在操作电动工具时瞬间的疏忽会导致严重人身伤害。
- 2) 使用个人防护装置。始终佩戴护目镜。
防护装置，诸如适当条件下使用防尘面具、防滑安全鞋、安全帽、听力防护等装置能减少人身伤害。
- 3) 防止意外起动。在连接电源和 / 或电池包、拿起或搬运工具前确保开关处于关断位置。
手指放在开关上搬运工具或开关处于接通时通电会导致危险。
- 4) 在电动工具接通之前，拿掉所有调节钥匙或扳手。
遗留在电动工具旋转零件上的扳手或钥匙会导致人身伤害。
- 5) 手不要过分伸展。时刻注意立足点和身体平衡。
这样能在意外情况下能更好地控制住电动工具。
- 6) 着装适当。不要穿宽松衣服或佩戴饰品。让你的头发和衣服远离运动部件。
宽松衣服、佩饰或长发可能会卷入运动部件。
- 7) 如果提供了与排屑、集尘设备连接用的装置，要确保其连接完好且使用得当。
使用集尘装置可降低尘屑引起的危险。
- 8) 不要因为频繁使用工具而产生的熟悉感而掉以轻心，忽视工具的安全准则。
某个粗心的动作可能在瞬间导致严重的伤害。

d) 电动工具使用和注意事项

- 1) 不要勉强使用电动工具，根据用途使用合适的电动工具。
选用合适的按照额定值设计的电动工具会使你工作更有效、更安全。
- 2) 如果开关不能通过或关断电源，则不能使用该电动工具。
不能用开关来控制的电动工具是危险的且必须进行修理。
- 3) 在进行任何调节、更换附件或贮存电动工具之前，必须从电源上拔掉插头和 / 或卸下电池包（如可拆卸）。
这种防护性的安全措施降低了电动工具意外起动的风险。

中文

- 4) 将闲置不用的电动工具贮存在儿童所及范围之外，并且不允许不熟悉电动工具和不了解这些说明的人操作电动工具。
电动工具在未经培训的使用者手中是危险的。
- 5) 维护电动工具及其附件。检查运动部件是否调整到位或卡住，检查零件破损情况和影响电动工具运行的其他状况。如有损坏，应在使用前修理好电动工具。
许多事故是由维护不良的电动工具引发的。
- 6) 保持切削刀具锋利和清洁。
维护良好的有锋利切削刃的刀具不易卡住而且容易控制。
- 7) 按照使用说明书，并考虑作业条件和要进行的作业来选择电动工具、附件和工具的刀头等。
将电动工具用于那些与其用途不符的操作可能会导致危险情况。
- 8) 不要因为频繁使用工具而产生的熟悉感而掉以轻心，忽视工具的安全准则。
某个粗心的动作可能在瞬间导致严重的伤害。

e) 维修

- 1) 由专业维修人员使用相同的备件维修电动工具。
这将保证所维修的电动工具的安全。

注意！

不可让儿童和体弱人士靠近工作场所。

应将不使用的工具存放在儿童和体弱人士接触不到的地方。

电刨安全警告

- a) 等刨刀停止后再放置工具。外露的旋转刨刀可能会嵌入表面而引发可能的失控和严重的伤害事故。
- b) 因刨刀可能会触及自身软线，要通过绝缘握持面来握持工具。刨削到带电导线会使工具外露的金属零件带电而使操作者受到电击。
- c) 使用夹具或其他实用方法将工件固定和支撑在稳定的工作台面。用手或身体固定工件会使工件不稳引起失控。

其他安全警告

1. 请勿在刀片朝上的状态下使用电刨（作为静止型电刨）。

符号

警告！

如下所示的符号用于本机。使用前请务必理解其含意。







为降低伤害风险，用户必须阅读使用说明书

规格

电压	220 V ~
输入功率	580 W
切削宽度	82 mm
最大切削深度	1.5 mm
重量 (不含线缆)	2.5 kg
空载转速	17000 /min

标准附件

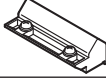
除了主机 (1 台) 外，产品包中还包括表中所列的附件。

套筒扳手 (刨刃锁定用)		1
定位规 (刃高调整用)		1
导板 (带止动螺丝)		1
刃磨组件 (用于反复磨锋型刀刃)		1
尘土适配器		1

选购附件 (分开销售)

1. 弯管
2. 尘土袋

用途

刨平木板与面板。(见图 1 - 4)

刨平



图 1

斜削

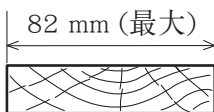

图 2

刨槽



图 3

尖削

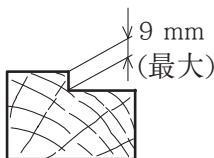

图 4

作业之前

1. 电源

确认所使用的电源与工具铭牌上标示的规格是否相符。

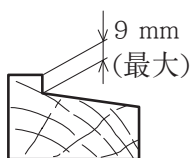
2. 电源开关

确认电源开关是否切断。若电源开关接通，则插头插入电源插座时电动工具将出其不意地立刻转动，从而招致严重事故。

3. 延伸电缆

若作业场所移到离开电源的地点，应使用容易足够、铠装合适的延伸线缆，并且要尽可能地短些。

4. 应事前备妥适于进行刨工，坚牢稳定的木制工作台架。工作台架稳定性差，可能导致危险，因此设置时必须检查地面是否坚牢稳定，并有足够的平坦度。

刨平方法

1. 开关操作

扳机开关解锁按钮用于防止电动工具的意外操作。要操作电动工具，需先将解锁按钮完全插入把手上的孔中。

只有按入解锁按钮才能操作扳机开关。

放开扳机开关后，电源断开，解锁按钮自动返回到初始位置，锁住扳机开关。

2. 调节刃深

(1) 按图 5 上箭头指示方向(顺时针方向)转动旋钮，

直到三角指标对准于度盘上的希望刃深刻度线。度盘上的刻度线以毫米为单位。

(2) 可在 0 - 1.5 mm 的范围内调节刃深。



图 5

3. 表面平刨

粗刨以较大的刃深和合适的速度进行作业，所以刨屑能够顺利地从电刨排出。但为了获得平滑的表面，还必须以较小的刃深和更低的速度进行精刨。

4. 刨削的起点和终点

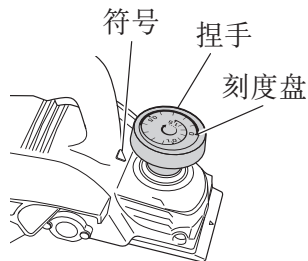
首先如图 6 所示，把电刨的前底部放在工作上，并使电刨保持水平状态。继而接通电源开关，徐徐操作电刨，把它推向工作前端。在刨削的第 1 阶段、必需稳固地按压电刨的前半部，而在接近终点时，则应如图 7 所示，按压电刨的后半部。进行作业时，自始至终，电刨都必需一直保持平直。

5. 刨完后应注意事项

刨完后，用一手提吊电刨时，切不可让刨刃触及身体的任一部份，也不可使刨刃过度靠近身体。如果忽略了这一点，可能导致严重的伤害事故，应十分注意。



图 6
切削起点



图 7

炭化刃之装卸和刀刃高度之调整 (适用于双刃型)

1. 炭化刃的拆卸

- (1) 如图 8 所示，用附带的套筒扳手松开刀架。
- (2) 如图 9 所示，用附带的套筒扳手将炭化刃拆下。

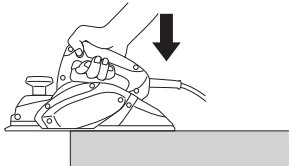
注意！

注意，拆卸时勿伤着您的手指。

2. 炭化刃的安装

注意！

在安装前，请彻底擦除炭化刃上积存着的碎屑。

- (1) 如图 10 所示，抬起定位板 (B) 将新的炭化刃插入刀刃座与定位板 (B) 之间。
- (2) 如第 8 页的图 11 所示，使新的炭化刃在定位板 (B) 上移动并将其装上，使刀刃端会从刀刃座端伸出 1 mm。
- (3) 如第 8 页的图 12 所示，更换刀刃完毕后，请拧紧刀架上的螺栓。



图 8



图 9

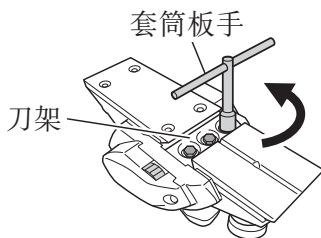

图 10

(4) 将刀刃座向上转动，用同样方法设置其他面。

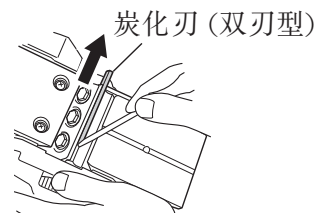

图 11

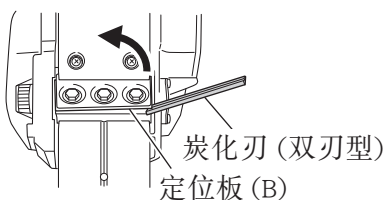

图 12

3. 调整炭化刃之高度

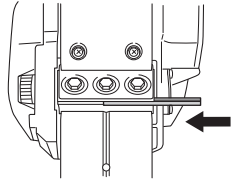
注意！

若上述操作结束之后，炭化刃之高度不够精确，则请执行下述操作。

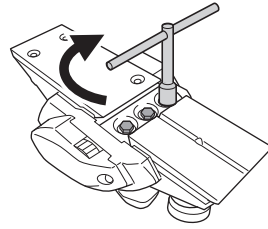
- (1) 如图 13 所示，用套筒扳手松开用于固定刀刃座的 3 根螺栓并将其拆下。
- (2) 如图 14 所示，拆下化刃之后，按箭头所示方向滑动定位板 (B) 并将其拆下。
- (3) 松开固定炭化刃，定位板 (A) 和定位板 (B) 的 2 颗螺钉。
- (4) 如图 15、16 所示，请一面将炭化刃缘调至定位规的墙面 a，一面将定位板 (A) 的转动面按至墙面 b。然后紧拧 2 颗螺钉固定之。
- (5) 如图 17、18 所示，将安装在定位板 (B) 上的定位板 (A) 的转动部份插入刀刃座平坦部份的槽中。
- (6) 如图 19 所示，将刀架置于已完成组件之上，并用 3 个螺栓固定之。务请拧紧螺栓。对反侧的炭化刃也请按相同方法进行。



图 13



图 14

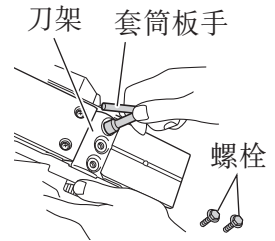

图 15

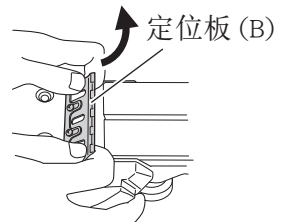

图 16

刀刃座的平坦部份



图 17

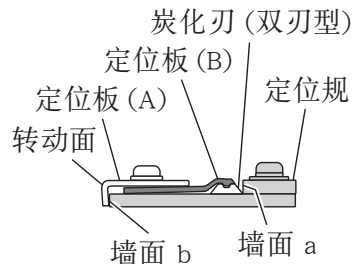

图 18

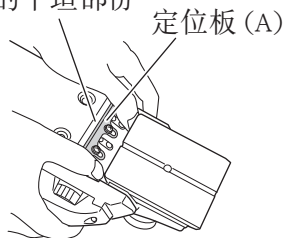

图 19

刀刃的装卸及刀刃高度之调整 (适用于反复磨锋型刀刃)

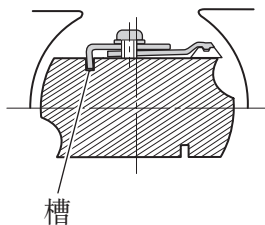
1. 刀刃的拆卸

- (1) 如图 13 所示, 用自带的套筒扳手松开用于固定刀刃的 3 个螺栓并卸下刀架。
- (2) 如图 14 所示, 按箭头方向滑动刀刃并将其卸下。

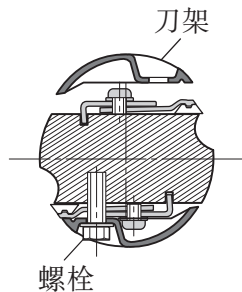
注意!

注意, 拆卸时勿伤着您的手指。

2. 刀刃的安装

注意!

在安装前, 请彻底擦除刀刃上附着的碎屑。

- (1) 将安装在刀刃上的定位板 (A) 的转动部份插入位于刀刃座平坦部份的槽中(见图 17, 20)。安上刀刃, 使刀刃的两面均从刀刃座的边缘伸出约 1 mm (见图 21)。
- (2) 如图 22 所示, 将刀架置于已完成的组件之上, 并用 3 根螺栓固定之。务请拧紧螺栓。
- (3) 向上转动刀刃座, 对其反侧也请按相同方法进行设置。

3. 刀刃高度的调整

- (1) 松开固定刀刃和定位板 (A) 的 2 颗螺钉。



图 20



图 21

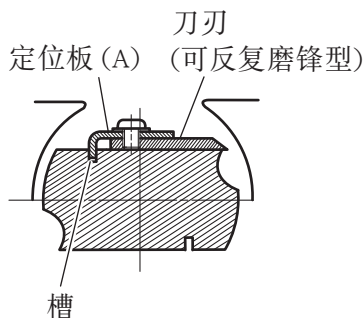

图 22

中文

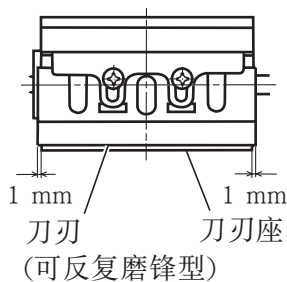
- (2) 请一面将刀刃缘调至定位规的墙面 a，一面将定位板(A)的转动面按至墙面 b。然后，拧紧 2 颗螺钉固定之（见第8页的图 15，图 23）。

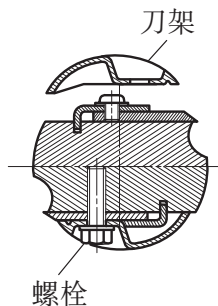

图 23

研磨可反复磨锋的刀刃

为方便起见，建议您使用附带的刃磨组件。

1. 使用刃磨组件

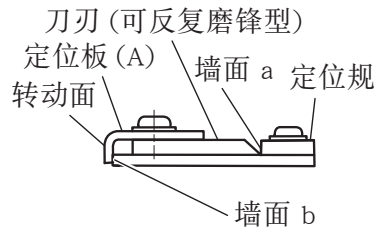
如图 24 所示，可将两片刀刃安在刃磨组件上并确保刃以相同的角度研磨。如图 25 所示，在研磨时，请调整刀刃的位置以使两者的刃缘同时与磨石相接触。

2. 刀刃磨锋间隔

磨锋刀刃的间隔一依所切割的木材类型和切割深度而异。但每当切割 500 m 木材之后，通常锋利度就会受到影响。

3. 磨石

在使用水磨石之前，请先将其在水中充分浸泡。因为这种磨石可能会在研磨作业中磨损。有必要时，请随时将磨石表面磨平。



图 24



图 25

装卸尘适配器

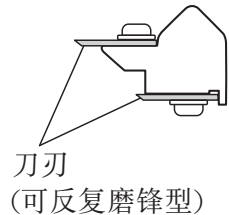
注意！

- 为了防止事故的发生，请务必切断电源，并将插头从电源插座上拔下。
- 按照下列步骤，切实安装尘适配器。否则适配器可能会脱落，造成受伤。

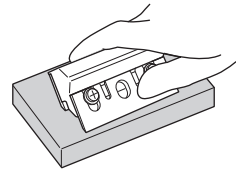
1. 安装尘适配器

- (1) 取下切屑盖内的螺钉 D4×16，如图 26 所示地拆下切屑盖。



图 26

(2) 安装尘适配器，并用螺钉D4×16固定。(图 27)

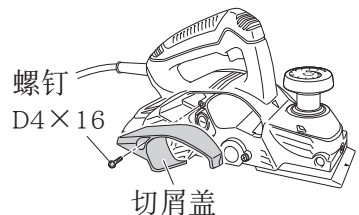

图 27

注：
装卸尘适配器和切屑盖时请注意不要折弯爪扣。

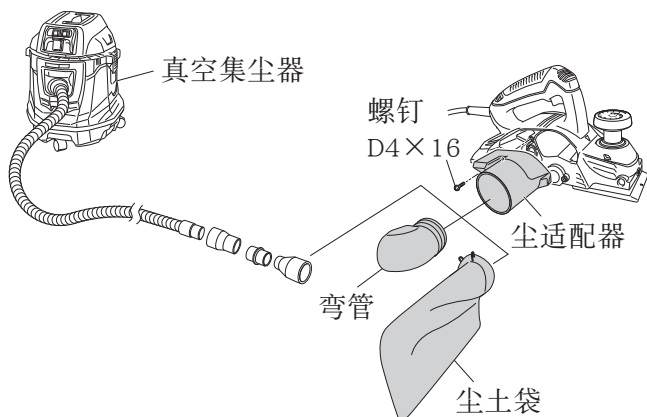
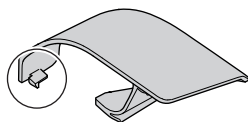

2. 拆卸尘适配器

要拆卸尘适配器，请按与上述相反的步骤操作。

维护和检查

1. 刀刃的检查

继续使用迟钝或损坏的刀刃将会导致切屑效率的降低及马达的超载。视需要经常磨锋或更换刀刃。

2. 操作

注意！

前底座、后底座和切削控制捏手经过精密加工，以确保高精度。如果这些部件受到粗暴的处理或过度的机械冲击，可能会影响精度，降低切削效果。处理这些部件必须特别小心。

3. 检查安装螺钉

要经常检查安装螺钉是否紧固妥善。若发现螺钉松了，应立即重新扭紧，否则会导致严重的事故。

4. 检查炭刷 (图 28)

电动机上的炭刷是一种消耗品，其磨损程度一旦超出了“磨损极限”，电动机将发生故障。因此，磨损了的炭刷应即更换新件。此外，炭刷必须常保持干净状态，这样才能在刷握里自由滑动。



图 28

5. 更换炭刷 (图 28)

卸下片盖之后，请使用带槽螺丝起子拆下刷盖。然后您就可方便地用弹簧来更换炭刷。

6. 电动机的维护

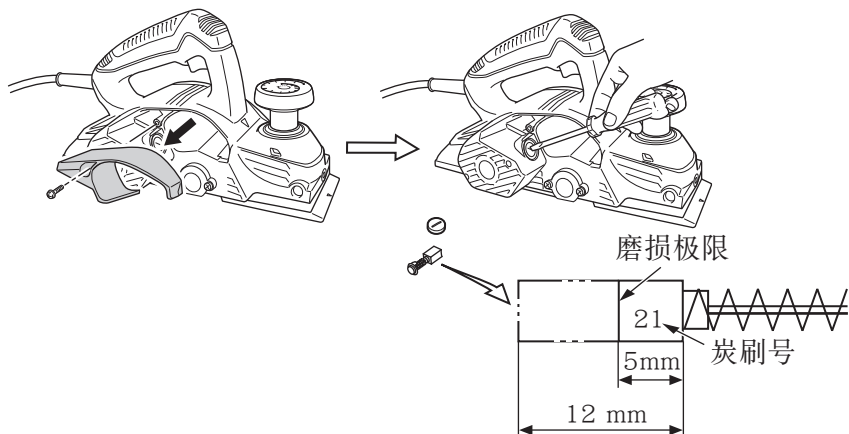
电动机绕线此电动工具的重要部件。应避免损伤，注意不要被油液或水沾湿。使用 50 小时后，请用空气枪或其他工具向电动机外壳通风口内吹入干燥的空气，仔细清洁电动机 (图 29)。电动机中灰尘或杂质颗粒堆积可能会导致故障。

7. 更换电源线

必须更换电源线时，应由HiKOKI公司授权的维修中心来更换，以避免安全危险。

8. 更换皮带

如果需要更换皮带，请联系 HiKOKI 授权服务中心进行操作，以免发生危险。



图 29

注意！

在操作和维修电动工具时，必须遵守贵国制定的安全的有关规则和标准。

附加信息

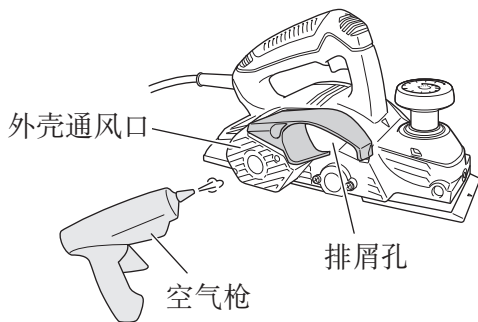
生产月份和年份的数据见机器和包装的铭牌,以数字和字母编码的月份:1-9 是1-9月、O是10月、N是11月、D是12月,生产年份按当年度最后一位数字编码。

CONTENTS

GENERAL POWER TOOL SAFETY WARNINGS	14
PLANER SAFETY WARNINGS	17
ADDITIONAL SAFETY WARNINGS	17
SYMBOL.....	17
SPECIFICATIONS	17
STANDARD ACCESSORIES	17
OPTIONAL ACCESSORIES (sold separately).....	18
APPLICATIONS.....	18
PRIOR TO OPERATION.....	18
PLANING PROCEDURES	19
CARBIDE BLADE ASSEMBLY AND DISASSEMBLY AND ADJUSTMENT OF CUTTER BLADE HEIGHT (FOR DOUBLE EDGED BLADE TYPE).....	20
BLADE ASSEMBLY AND DISASSEMBLY AND ADJUSTMENT OF BLADE HEIGHT (FOR RESHARPENABLE BLADE TYPE).....	22
SHARPENING THE RESHARPENABLE BLADES.....	23
ATTACHING AND DETACHING THE DUST ADAPTER	23
MAINTENANCE AND INSPECTION	24
ADDITIONAL INFORMATION	26

GENERAL POWER TOOL SAFETY WARNINGS

WARNING

Read all safety warnings, instructions, illustrations and specifications provided with this power tool.

Failure to follow all instructions listed below may result in electric shock, fire and/or serious injury.

Save all warnings and instructions for future reference.

The term “power tool” in the warnings refers to your mains-operated (corded) power tool or battery-operated (cordless) power tool.

- 1) **Work area safety**
 - a) **Keep work area clean and well lit.**
Cluttered or dark areas invite accidents.
 - b) **Do not operate power tools in explosive atmospheres, such as in the presence of flammable liquids, gases or dust.**
Power tools create sparks which may ignite the dust or fumes.
 - c) **Keep children and bystanders away while operating a power tool.**
Distractions can cause you to lose control.

2) Electrical safety

- a) **Power tool plugs must match the outlet.**
Never modify the plug in any way.
Do not use any adapter plugs with earthed (grounded) power tools.
Unmodified plugs and matching outlets will reduce risk of electric shock.
- b) **Avoid body contact with earthed or grounded surfaces, such as pipes, radiators, ranges and refrigerators.**
There is an increased risk of electric shock if your body is earthed or grounded.
- c) **Do not expose power tools to rain or wet conditions.**
Water entering a power tool will increase the risk of electric shock.
- d) **Do not abuse the cord. Never use the cord for carrying, pulling or unplugging the power tool.**
Keep cord away from heat, oil, sharp edges or moving parts.
Damaged or entangled cords increase the risk of electric shock.
- e) **When operating a power tool outdoors, use an extension cord suitable for outdoor use.**
Use of a cord suitable for outdoor use reduces the risk of electric shock.
- f) **If operating a power tool in a damp location is unavoidable, use a residual current device (RCD) protected supply.**
Use of an RCD reduces the risk of electric shock.

3) Personal safety

- a) **Stay alert, watch what you are doing and use common sense when operating a power tool.**
Do not use a power tool while you are tired or under the influence of drugs, alcohol or medication.
A moment of inattention while operating power tools may result in serious personal injury.
- b) **Use personal protective equipment. Always wear eye protection.**
Protective equipment such as a dust mask, non-skid safety shoes, hard hat or hearing protection used for appropriate conditions will reduce personal injuries.
- c) **Prevent unintentional starting. Ensure the switch is in the off position before connecting to power source and/or battery pack, picking up or carrying the tool.**
Carrying power tools with your finger on the switch or energising power tools that have the switch on invites accidents.
- d) **Remove any adjusting key or wrench before turning the power tool on.**
A wrench or a key left attached to a rotating part of the power tool may result in personal injury.
- e) **Do not overreach. Keep proper footing and balance at all times.**
This enables better control of the power tool in unexpected situations.
- f) **Dress properly. Do not wear loose clothing or jewellery. Keep your hair and clothing away from moving parts.**
Loose clothes, jewellery or long hair can be caught in moving parts.
- g) **If devices are provided for the connection of dust extraction and collection facilities, ensure these are connected and properly used.**
Use of dust collection can reduce dust-related hazards.

English

- h) **Do not let familiarity gained from frequent use of tools allow you to become complacent and ignore tool safety principles.**

A careless action can cause severe injury within a fraction of a second.

4) Power tool use and care

- a) **Do not force the power tool. Use the correct power tool for your application.**

The correct power tool will do the job better and safer at the rate for which it was designed.

- b) **Do not use the power tool if the switch does not turn it on and off.**

Any power tool that cannot be controlled with the switch is dangerous and must be repaired.

- c) **Disconnect the plug from the power source and/or remove the battery pack, if detachable, from the power tool before making any adjustments, changing accessories, or storing power tools.**

Such preventive safety measures reduce the risk of starting the power tool accidentally.

- d) **Store idle power tools out of the reach of children and do not allow persons unfamiliar with the power tool or these instructions to operate the power tool.**

Power tools are dangerous in the hands of untrained users.

- e) **Maintain power tools and accessories. Check for misalignment or binding of moving parts, breakage of parts and any other condition that may affect the power tool's operation.**

If damaged, have the power tool repaired before use.

Many accidents are caused by poorly maintained power tools.

- f) **Keep cutting tools sharp and clean.**

Properly maintained cutting tools with sharp cutting edges are less likely to bind and are easier to control.

- g) **Use the power tool, accessories and tool bits etc. in accordance with these instructions, taking into account the working conditions and the work to be performed.**

Use of the power tool for operations different from those intended could result in a hazardous situation.

- h) **Keep handles and grasping surfaces dry, clean and free from oil and grease.**

Slippery handles and grasping surfaces do not allow for safe handling and control of the tool in unexpected situations.

5) Service

- a) **Have your power tool serviced by a qualified repair person using only identical replacement parts.**

This will ensure that the safety of the power tool is maintained.

CAUTION

Keep children and infirm persons away.

When not in use, tools should be stored out of reach of children and infirm persons.

PLANER SAFETY WARNINGS

- 1. Wait for the cutter to stop before settling the tool down.**
An exposed rotating cutter may engage the surface leading to possible loss of control and serious injury.
- 2. Hold the power tool by insulated gripping surfaces, because the cutter may contact its own cord.** Cutting a "live" wire may make exposed metal parts of the power tool "live" and could give the operator an electric shock.
- 3. Use clamps or another practical way to secure and support the workpiece to a stable platform.** Holding the workpiece by your hand or against the body leaves it unstable and may lead to loss of control.

ADDITIONAL SAFETY WARNINGS

1. Do not use the Planer with the blades facing upward (as stationary type planer).

SYMBOL

WARNING

The following show symbols used for the machine. Be sure that you understand their meaning before use.

	To reduce the risk of injury, user must read instruction manual.
--	--

SPECIFICATIONS



Voltage	220 V~
Power Input	580 W
Cutting Width	82 mm
Max. Cutting Depth	1.5 mm
Weight (without cord and guide)	2.5 kg
No-Load Speed	17000 /min

STANDARD ACCESSORIES

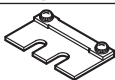
In addition to the main unit (1 unit), the package contains the accessories listed in the below.

Box Wrench (for securing cutter blade)		1
Set Gauge (for adjusting cutter height)		1

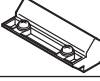
English

Guide (with set screw)		1
Blade Sharpening Ass'y (for Resharpenable Blade Type)		1
Dust adapter		1

OPTIONAL ACCESSORIES (sold separately)

1. Elbow
2. Dust bag

APPLICATIONS

Planing various wooden planks and panels. (See Fig. 1-4)

Planing

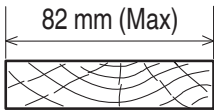

Fig. 1

Beveling



Fig. 2

Rabbeting

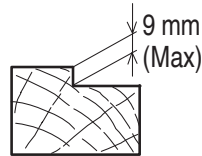

Fig. 3

Tapering

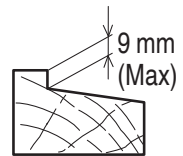

Fig. 4

PRIOR TO OPERATION

1. Power source
Ensure that the power source to be utilized conforms to the power requirements specified on the product nameplate.
2. Power switch
Ensure that the power switch is in the OFF position. If the plug is connected to a receptacle while the power switch is in the ON position, the power tool will start operating immediately, which could cause a serious accident.
3. Extension cord
When the work area is removed from the power source. Use an extension cord of sufficient thickness and rated capacity. The extension cord should be kept as short as practicable.
4. Prepare a stable wooden workbench suitable for planing operation. As a poorly balanced workbench creates a hazard, ensure it is securely positioned on firm, level ground.

PLANING PROCEDURES

1. Operation of the switch

The trigger switch lock-off button is designed to prevent inadvertent operation of the power tool. To operate the power tool, it is necessary to first fully insert the lock-off button into the hole on the handle.

The trigger switch will not operate unless the lock-off button has been pushed in.

When the trigger switch is released, the power goes off and the lock-off button automatically returns to its initial position, locking the trigger switch.

2. Adjusting the cutter depth

(1) Turn the knob in the direction indicated by the arrow in **Fig. 5** (clockwise), until the triangular mark is aligned with the desired cutting depth on the scale. The scale unit is graduated in millimeters.

(2) The cutting depth can be adjusted within a range of 0 – 1.5 mm.

3. Surface cutting

Rough cutting should be accomplished at large cutting depths and at a suitable speed so that shavings are smoothly ejected from the machine. To ensure a smoothly finished surface, finish cutting should be accomplished at small cutting depths and at low feeding speed.

4. Beginning and ending the cutting operation

As shown in **Fig. 6**, place the front base of the planer on the material and support the planer horizontally. Turn ON the power switch, and slowly operate the planer toward the leading edge of the material. Firmly depress the front half of the planer at the first stage of cutting, as shown in **Fig. 7**, depress the rear half of the planer at the end of the cutting operation. The planer must always be kept flat throughout the entire cutting operation.

5. Precaution after finishing the planing operation

When the planer is suspended with one hand after finishing the planing operation, ensure that the cutting blades (base) of the planer do not contact or come too near your body. Failure to do so could result in serious injury.

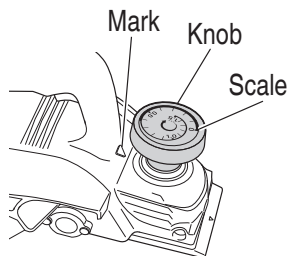

Fig. 5

Beginning of cutting operation

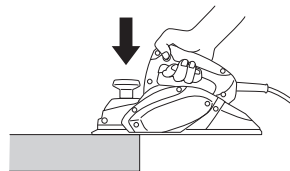

Fig. 6

End of cutting operation

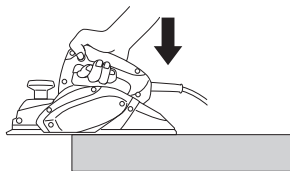

Fig. 7

CARBIDE BLADE ASSEMBLY AND DISASSEMBLY AND ADJUSTMENT OF CUTTER BLADE HEIGHT (FOR DOUBLE EDGED BLADE TYPE)

1. Carbide blade disassembly
 - (1) As shown in **Fig. 8**, loosen the blade holder with the attached box wrench.
 - (2) As shown in **Fig. 9**, remove the carbide blade by sliding it with the attached box wrench.

CAUTION

Be careful not to injure your hands.

2. Carbide blade assembly

CAUTION

Prior to assembly, thoroughly wipe off all swarf accumulated on the carbide blade.

- (1) As shown in **Fig. 10**, lift set plate (B) and insert the new carbide blade between cutter block and set plate (B).
- (2) As shown in **Fig. 11**, mount the new carbide blade by sliding it on the set plate (B) so that the blade tip projects by 1 mm from the end of the cutter block.
- (3) As shown in **Fig. 12**, fix the bolts at the blade holder after blade replacement has been completed.
- (4) Turn the cutter block over, and set the other side in the same manner.

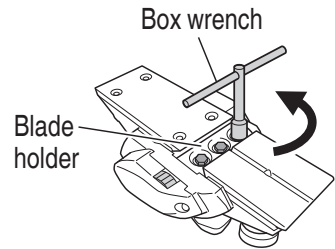

Fig. 8

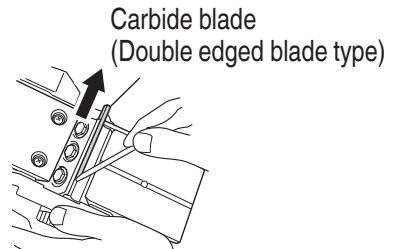

Fig. 9

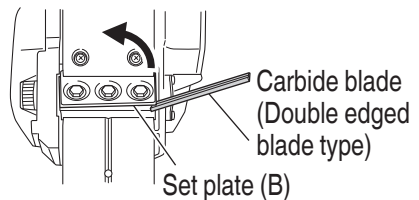

Fig. 10

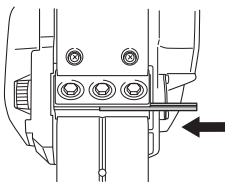

Fig. 11

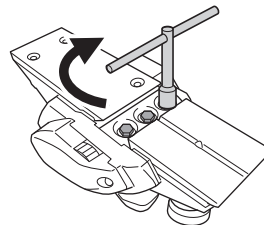

Fig. 12

3. Adjustment of carbide blade height

CAUTION

If the carbide blade's heights are inaccurate after above procedures have been completed, carry out the procedures described below.

- (1) As shown in **Fig. 13**, use the box wrench to loosen the three bolts used to retain the carbide blade, and remove the blade holder.
- (2) As shown in **Fig. 14**, after removing the carbide blade, slide set plate (B) in the direction indicated by the arrow to disassemble set plate (B).
- (3) Loosen the 2 screws holding on the carbide blade and set plate (A), set plate (B).
- (4) As shown in **Fig. 15, 16**, press the turned surface of set plate (A) to the wall surface b while adjusting the carbide blade edge to the wall surface a of the set gauge. Then, tighten them with the 2 screws.
- (5) As shown in **Fig. 17, 18**, insert a turned portion of set plate (A) attached to set plate (B) into a groove on the flat portion of the cutter block.
- (6) As shown in **Fig. 19**, place the blade holder on the completed assembly and fasten it with the three bolts. Ensure that the bolts are securely tightened. Follow the same procedures for the opposite side carbide blade.

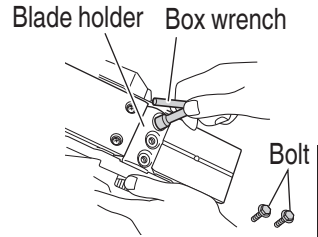

Fig. 13

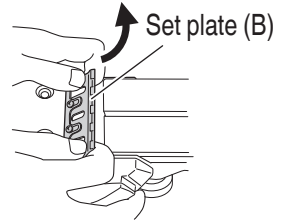

Fig. 14

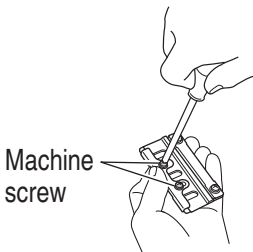

Fig. 15

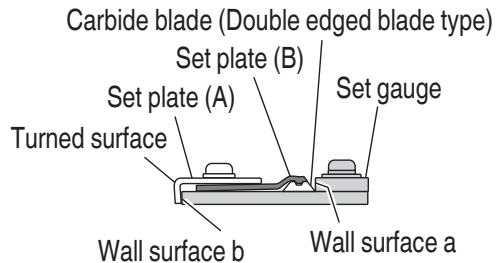

Fig. 16

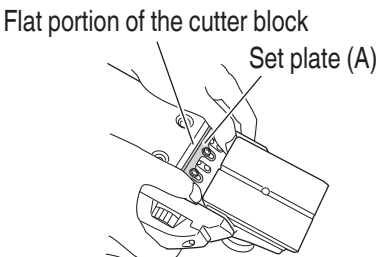

Fig. 17

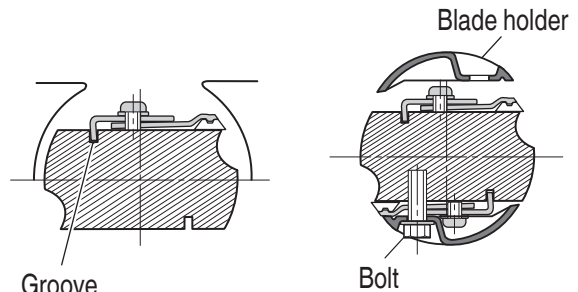

Fig. 18

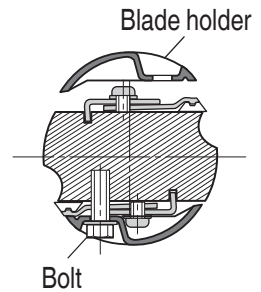

Fig. 19

BLADE ASSEMBLY AND DISASSEMBLY AND ADJUSTMENT OF BLADE HEIGHT (FOR RESHARPENABLE BLADE TYPE)

1. Blade disassembly
 - (1) As shown in **Fig. 13 on page 21**, use the accessory box wrench to loosen the three bolts used to retain the blade, and remove the blade holder.
 - (2) As shown in **Fig. 14 on page 21**, slide the blade in the direction indicated by the arrow to disassemble the blade.

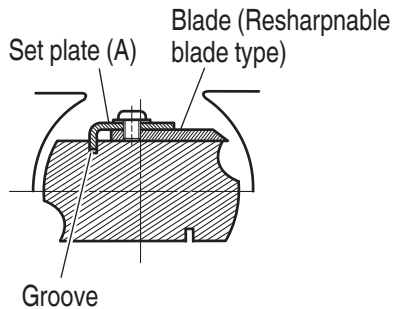

Fig. 20

CAUTION

Be careful not to injure your hands.

2. Blade assembly

CAUTION

Prior to assembly, thoroughly wipe off all swarf accumulated on the blade.

- (1) Insert a turned portion of set plate (A) attached to the blade into a groove on the flat portion of the cutter block. (**Fig. 17 on page 21** and **Fig. 20**) Set the blade so that both sides of the blade protrude from the width of the cutter block by about 1 mm (**Fig. 21**)
- (2) Place the blade holder on the completed assembly, as shown in **Fig. 22**, and fasten it with the three bolts. Ensure that the bolts are securely tightened.
- (3) Turn the cutter block over, and set the opposite side in the same manner.

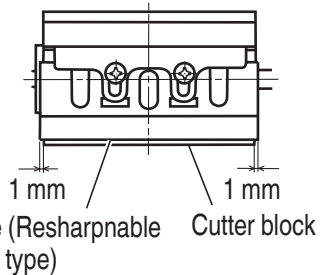

Fig. 21

3. Adjustment of blade height

- (1) Loosen the 2 screws holding on the blade and set plate (A).
- (2) Press the turned surface of set plate (A) to the wall surface *b* while adjusting the blade edge to the wall surface *a* of the set gauge. Then, tighten them with the 2 screws. (**Fig. 15 on page 21** and **Fig. 23**)

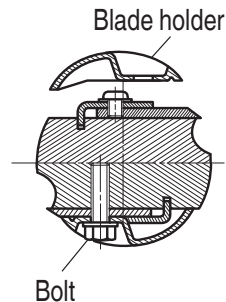

Fig. 22

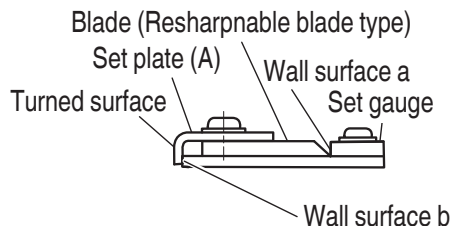
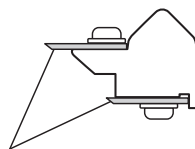

Fig. 23

SHARPENING THE RESHARPENABLE BLADES

Use of the accessory Blade Sharpening Ass'y is recommended for convenience.

1. Use of Blade Sharpening Ass'y
As shown in **Fig. 24**, two blades can be mounted on the blade sharpening ass'y to ensure that the blade tips are ground at uniform angles. During grinding, adjust the position of the blades so that their edges simultaneously contact the dressing stone as shown in **Fig. 25**.
2. Blade sharpening intervals
Blade sharpening intervals depend on the type of wood being cut and the cutting depth. However, sharpening should generally be effected after each 500 meters of cutting operation.
3. Dressing Stone
When a water dressing stone is available, use it after dipping it sufficiently in water since such a dressing stone may be worn during grinding works, flatten the upper surface of the dressing stone as often as necessary.



Blade (Resharpnable blade type)

Fig. 24

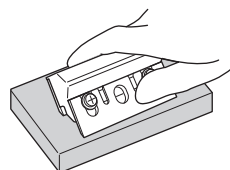

Fig. 25

ATTACHING AND DETACHING THE DUST ADAPTER

CAUTION

- To prevent accidents, ensure that the power tool is switched off and the plug is disconnected from the power source.
 - Follow the procedure below to mount the dust adapter securely. Failure to do so may result in the adapter coming off, causing injury.
1. Attaching the dust adapter
 - (1) Remove the screw D4 × 16 in the chip cover and remove the chip cover as shown in **Fig. 26**.

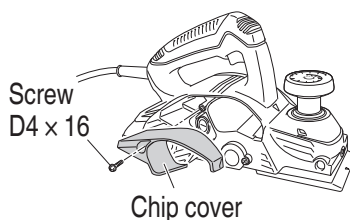

Fig. 26

English

- (2) Mount the dust adapter and secure with the screw D4 x 16. (Fig. 27)

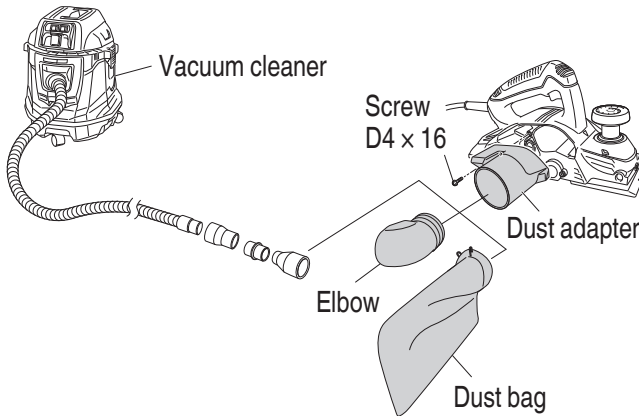
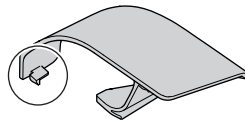

Fig. 27

NOTE

Take care not to break the catch when attaching or detaching the dust adapter and chip cover.



2. Removing the dust adapter
To remove the dust adapter, follow the procedure above in reverse order.

MAINTENANCE AND INSPECTION

1. Inspecting the blades
Continued use of dull or damaged blades will result in reduced cutting efficiency and may cause overloading of the motor. Sharpen or replace the blades as often as necessary.
2. Handling

CAUTION

The front base, rear base, and cutting depth control knob are precisely machined to obtain specifically high precision. If these parts are roughly handled or subjected to heavy mechanical impact, it may cause deteriorated precision and reduced cutting performance. These parts must be handled with particular care.

3. Inspecting the mounting screws
Regularly inspect all mounting screws and ensure that they are properly tightened. Should any of the screws be loose, retighten them immediately. Failure to do so could result in serious hazard.

4. Inspecting the carbon brushes (Fig. 28)

The motor employs carbon brushes which are consumable parts. Since an excessively worn carbon brush can result in motor trouble, replace the carbon brushes with new ones having the same carbon brush No. shown in the figure when it becomes worn to or near the “wear limit”. In addition, always keep carbon brushes clean and ensure that they slide freely within the brush holders.

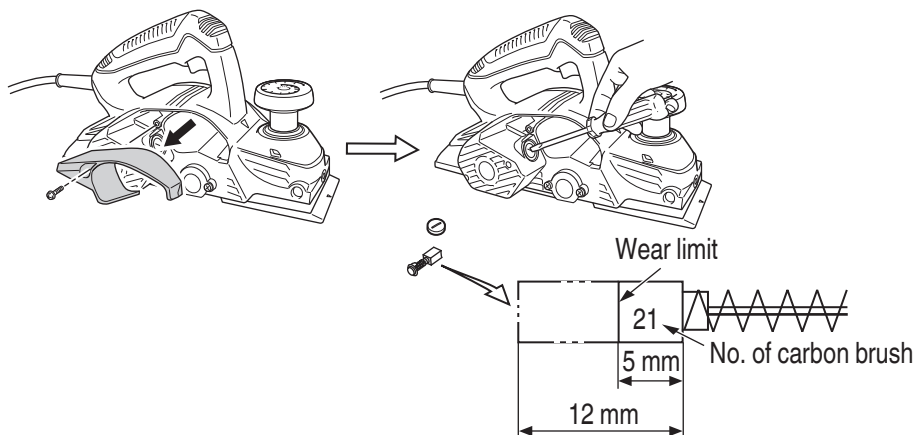

Fig. 28

5. Replacing carbon brushes (Fig. 28)

After removing the chip cover, use a slotted screwdriver to disassemble the brush caps. The carbon brushes can then be easily removed with the spring.

6. Motor unit maintenance

The motor winding is an important part of this tool. Avoid damaging and be careful to avoid contact with cleaning oil or water. After 50 hours of use, clean the motor by blowing into the ventilation holes of the motor housing with dry air from an air gun or other tool (Fig. 29). Dust or particle accumulation in the motor can result in damage.

7. Replacing supply cord

If the replacement of the supply cord is necessary, this has to be done by HiKOKI Authorized Service Center in order to avoid a safety hazard.

8. Replacing belt

If the replacement of the belt is necessary, it has to be done by HiKOKI Authorized Service Center to avoid a safety hazard.

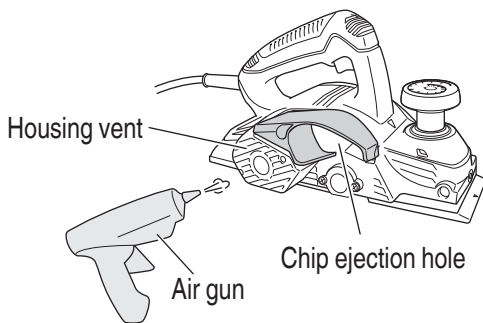

Fig. 29

CAUTION

In the operation and maintenance of power tools, the safety regulations and standards prescribed in each country must be observed.

ADDITIONAL INFORMATION

Data about month and year of production see at name plate of machine and package. Months coded by digits and letters: 1-9 – Jan-Sept, O-Oct, N-Nov, D-Dec. Year of production coded by last digit of current year.

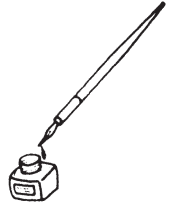

服务中心
高壹工机商业(上海)有限公司
上海市闵行区浦江工业园区三鲁路3585号7幢3楼

制造商
福建高壹工机有限公司
福建省福州市福兴投资区湖塘路

Koki Holdings Co., Ltd.

110
编号: C99202628 F
发行日期: 2021年 10月
中国印刷